



YEAR	MODEL	BALL JOINT UPPER	BALL JOINT LOWER / KING PIN SET	IDLER	TIE ROD END L/H OUTER	TIE ROD END R/H OUTER	TIE ROD END L/H INNER	TIE ROD END R/H INNER	RACK END	SIDE ROD	CENTRE ROD	DRAG LINK	PITMAN	NOTES/OTHER
------	-------	---------------------	--	-------	--------------------------	--------------------------	--------------------------	--------------------------	-------------	-------------	---------------	--------------	--------	-------------











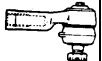

ALFA ROMEO

**A
l
f
a**

	33													
1983-on	Alfa 33 and Alfa 33 Boxer (5 door)		BJ962		TE3620R	TE3620R								
	75													
5/85-92	Alfa 75 - power steer	BJ1158 2 bolt mount	BJ844 screw-in		TE3621R	TE3621R			RE1004					RE1004 - M14x1.5 Power Steer
5/85-92	Alfa 75 - manual steer	BJ1158 2 bolt mount	BJ844 screw-in		TE3621R	TE3621R			RE8925					RE8925 - RHT M14x1.5 Manual Steer
	90													
1984-on	Alfa 90 - power steer	BJ1158 2 bolt mount	BJ844 screw-in		TE3621R	TE3621R			RE1004					RE1004 - M14x1.5 Power Steer
1984-on	Alfa 90 - manual steer	BJ1158 2 bolt mount	BJ844 screw-in		TE3621R	TE3621R			RE8925					RE8925 - RHT M14x1.5 Manual Steer
	156													
1997-on	Alfa 156				TE7919	TE7920			RE7923					
	164													
1987-92	Alfa 164 2.0 litre Twin Spark & Twin Spark Super		BJ1159		TE2405 RHT M14x1.5	TE2405 RHT M14x1.5			RE1006 RHT M14x1.5					BJ1159 - Ball Stud Diam 13mm
1987-92	Alfa 164 3.0 litre V6		BJ5182		TE2405 RHT M14x1.5	TE2405 RHT M14x1.5			RE1006 RHT M14x1.5					BJ5182 - Ball Stud Diam 15mm
	166													
1998-on	Alfa 166				TE7919	TE7920			RE8297					
	ALFA SUD													
1974-84	Alfa Sud 1200, 1500		BJ2213		TE3620R	TE3620R								
	ALFETTA, GUILLETTA													
1974-84	Alfetta, Guiletta 1800, 2000	BJ843 2 bolt mount	BJ844 screw-in		TE3621R	TE3621R								
1984-87	Alfetta,GTV,Guiletta	BJ843 2 bolt mount	BJ844 screw-in		TE3621R	TE3621R								
	BERLINA													
1967-on	Berlina 1750,2000		BJ159		TE402R	TE402R	TE402L	TE402L						RH-TE495R LH-TE495L

STEERING and SUSPENSION COMPONENTS



YEAR	MODEL	BALL JOINT UPPER 	BALL JOINT LOWER / KING PIN SET 	IDLER 	TIE ROD END L/H OUTER 	TIE ROD END R/H OUTER 	TIE ROD END L/H INNER 	TIE ROD END R/H INNER 	RACK END 	SIDE ROD 	CENTRE ROD 	DRAG LINK 	PITMAN 	NOTES/OTHER
------	-------	--	---	--	--	---	---	---	--	--	--	---	---	-------------

	GUILIA, etc.													
1962-78	Guilia, Spider, 1300, 1600		BJ159		TE402R	TE402R	TE402L	TE402L						RH-TE495R LH-TE495L
1972-76	Montreal, Zagato, Junior		BJ159		TE402R	TE402R	TE402L	TE402L						RH-TE495R LH-TE495L

AMC

**A
M
C**

1958-61	Ambassador 5880,5980,6080,6180 8cyl	SX77			TE423L	TE423L								
1958-61	Classic, Rebel 5820,5920,6020,6120 8cyl	SX77			TE423L	TE423L								
1962-66	Classic 6210,6310,6410, Ambassador, Six, Classic Six, Marlin Six 6cyl	SX77	BJ17		TE423L	TE423L	TE394R	TE394R						
1962-66	Ambassador 6280,6380, Ambassador Eight, Marlin Eight 8cyl	SX77	BJ17		TE423L	TE423L	TE394R	TE394R						
1964-69	AMX30, Javelin 70, American, Rambler, Rogue 01				TE424L	TE424L								
1967-69	Ambassador, Marlin, Rebel	SX77	BJ17		TE423L	TE423L	TE394R	TE394R						
1970-83	Ambassador 80, AMX30, Gremlin 40, Hornet	10229	10228	18741	TE424L	TE424L								TE424L - 5/8" thread
1970-78	Matador, Rebel	10229	10228		TE424L	TE424L								
1970-83	Javelin, Hornet	10229	10228		TE424L	TE424L								

**A
U
D
I**

	Audi 80													
1973-78	1.3, 1.5, 1.6L		BJ706		TE1717	TE1717								TE1717 - RHT M14x1.5
1978-81	1.3, 1.5, 1.6L		BJ2023		TE1717	TE1717								BJ2023 - Ball Stud Diam 17mm
7/72-81	80 Fox, GLS		BJ2023		TE3642R	TE3642R								BJ2023 - Ball Stud Diam 17mm
1986-87	1.8lt - to chassis# 81B095000		RH-BJ987 LH-BJ986		TE1717	TE1717								
1986-87	1.8lt - from chassis# 81B095001		RH-BJ987 LH-BJ986		TE1835	TE1835								TE1835 - RHT M14x1.5

STEERING and SUSPENSION COMPONENTS



YEAR	MODEL	BALL JOINT UPPER	BALL JOINT LOWER / KING PIN SET	IDLER	TIE ROD END L/H OUTER	TIE ROD END R/H OUTER	TIE ROD END L/H INNER	TIE ROD END R/H INNER	RACK END	SIDE ROD	CENTRE ROD	DRAG LINK	PITMAN	NOTES/OTHER
------	-------	------------------	---------------------------------	-------	-----------------------	-----------------------	-----------------------	-----------------------	----------	----------	------------	-----------	--------	-------------

Audi

1988-91	Quattro 1.8lt - to chassis# 89J351000		RH-BJ987 LH-BJ986		TE1835	TE1835								
1988-91	Quattro 1.8lt - from chassis# 89J351001		RH-BJ1164 LH-BJ1165		TE1835	TE1835								BJ1164/BJ1165 - Ball Stud Diam 19mm
1989-on	Quattro 2.0lt		RH-BJ1164 LH-BJ1165		TE1835	TE1835								BJ1164/BJ1165 - Ball Stud Diam 19mm
1993-on	Quattro 2.6lt				TE1835	TE1835								
	Audi 90													
1989-91	Quattro 2.3lt				TE1835	TE1835								
	Audi 100													
1968-77	LS, GL, 1.6, 1.8, 1.9, 2.0 excl. Coupa	BJ721	BJ722		TE1708	TE1708								TE1708 - 1974-77
1983-on	2.1, 2.2, 2.3, 2.6, 2.8L				TE2065	TE2066								
	A4													
1995-on	A4 & A4 Avant & A4 Quattro				TE9811	TE9811			RE2821					
	A6													
1995-on	A6 & A6 Avant & A6 Quattro				TE9813 RHT M16x1.5)	TE9812 RHT M16x1.5)								
1997-on	A6				TE9811 RHT M14x1.5	TE9811 RHT M14x1.5			RE2821					
	A8													
1994-on	A8 & A8 Quattro				TE9811	TE9811			RE2821					

AUSTIN - see LEYLAND

Bedford

BEDFORD														
1952-54	Bedford CA Van	RH-BJ19 LH-BJ20	KX163		TE106L	TE106R	TE106R	TE106L						Lower Outer - SX28 Upper Inner Control Arm - SX1021A Lower Inner Control Arm - SX1022A
1955-70	Bedford CA Van (10, 12 Cwt) 9600 Series	RH-BJ19 LH-BJ20	KX163		TE125L	TE125R	TE125R	TE125L						Lower Outer - SX28 Upper Inner Control Arm - SX1021A Lower Inner Control Arm - SX1022A
1957-72	C4,C5,C6 (Petrol) 4-6ton, D5,D6L 5-6ton				TE110L	TE110R								

STEERING and SUSPENSION COMPONENTS



YEAR	MODEL	BALL JOINT UPPER	BALL JOINT LOWER / KING PIN SET	IDLER	TIE ROD END L/H OUTER	TIE ROD END R/H OUTER	TIE ROD END L/H INNER	TIE ROD END R/H INNER	RACK END	SIDE ROD	CENTRE ROD	DRAG LINK	PITMAN	NOTES/OTHER
------	-------	------------------	---------------------------------	-------	-----------------------	-----------------------	-----------------------	-----------------------	----------	----------	------------	-----------	--------	-------------

Bedford

	J4,J5,CD,CF,CJ 5-8ton													
1959-81	Bedford J, TK, E, G Series - inc. J1, J2 & J3 to chassis# IT193139 - 16" WHEELS		KX196		TE56L	TE56R							DL370	King pin set .999" x 5.906"
1971-81	TK & E series, KA,KB,EOF,EOG,EDF,EDG,EHG,EHF 1.5-4ton from chassis# 2T120001		KX204		TE368L	TE368R								King pin set 1.250" x 6.825"
1960-81	EFQ,EJQ,EPQ,EFR,EJR,EPR series 7-8ton		KX249		TE369L	TE369R								King pin set 1.375" x 7.500"
1967-81	EDN,EFN,EJN,EON 6ton to chassis# 1T177868		KX213 KX250		TE368L	TE368R							DL258 DL260 1971-on	KX213 = thin bushes .421 thrust brg KX250 = wide bushes .625 thrust brg King pin set 1.375" x 7.500"
1967-81	EDN,EFN,EJN,EON 6ton from chassis# 1T193139		KX213 KX250		TE369L	TE369R							DL258 DL260 1971-on	KX213 = thin bushes .421 thrust brg KX250 = wide bushes .625 thrust brg King pin set 1.375" x 7.500"
1968-81	KC,KD,KE,EOL,EOM,EDL,EHC,EDM,EHM,EJM 3-5ton		KX204		TE368L	TE368R							DL258	King pin set 1.250" x 6.825"
1964-70	Bedford Handi Van, Beagle Estate	BJ42	BJ57		TE179R	TE179R								
1968-76	Bedford COD,COJ,COL (To 4 Ton)		KX196		TE56L	TE56R							DL370	King pin set .999" x 5.906"
1969-87	Bedford CF, 97000 (18-35Cwt) up to chassis# CY636000 <i>CF Model with Holden Motor</i>	BJ24	BJ268 41.5mm body diameter		TE476R	TE476R								BJ268 - To chassis# CY636000
1969-87	Bedford CF, 97000 (18-35Cwt) from chassis# DY600001 <i>CF Model with Holden Motor</i>	BJ24	BJ148 43.2mm body diameter		TE476R	TE476R								BJ148 - From chassis# DY600001
1979-on	D & TL series, Fwd.Control, DOA, DOG, DOL,DOM,TL570,TL750,TL860 5.6-7.37ton		KX204		TE368L	TE368R								King pin set 1.250" x 6.750"
1979-on	DON,DOQ,DOR,TL1000,TL1020,TL1260 9.8-16ton		KX250		TE369L	TE369R								King pin set 1.375" x 7.500"
1967-76	MFR,MJR,RF,RJ (M SERIES 4WD)		KX607		TE342L	TE342R								King pin set 1.375" x 7.500"
1958-77	TJ series,J6,CFQ,CJQ,COQ,7ton,SA,SD,SL,SS		KX607		TE342L	TE342R								King pin set 1.375" x 7.500"

STEERING and SUSPENSION COMPONENTS



YEAR	MODEL	BALL JOINT UPPER	BALL JOINT LOWER / KING PIN SET	IDLER	TIE ROD END L/H OUTER	TIE ROD END R/H OUTER	TIE ROD END L/H INNER	TIE ROD END R/H INNER	RACK END	SIDE ROD	CENTRE ROD	DRAG LINK	PITMAN	NOTES/OTHER
------	-------	------------------	---------------------------------	-------	-----------------------	-----------------------	-----------------------	-----------------------	----------	----------	------------	-----------	--------	-------------

	SB,SB3,SB5,NF,NJ, Bus Chassis													
--	-------------------------------	--	--	--	--	--	--	--	--	--	--	--	--	--

BEDFORD - BUSES











1960-76	VAM series bus		KX249		TE3406L	TE3405R								King pin set 1.375" x 7.500"
1960-on	BLP series bus		KX213		TE3406L	TE3405R								King pin set 1.375" x 7.500" - .421 thrust brg
1960-on	Y series coaches (mid-mount engine) excluding YRQ		KX1230		TE6753L	TE6752R								King pin set 2.000" x 10.000"
1960-on	Y series coaches (mid-mount engine) YRQ only		KX1230		TE3406L	TE3405R								King pin set 2.000" x 10.000"
1960-on	N series school buses		KX250		TE368L	TE368R						8848262		King pin set 1.375" x 7.500" - .625 thrust brg
1960-on	SB series school buses		KX213		TE368L	TE369R						8848262		King pin set 1.375" x 7.500" - .421 thrust brg

**B
M
W**

1962-77	E10 - 1500/1502/1600/1602/1660/1800/1802 2000/2002/Ti/Tii	BJ2213	BJ2212 3 bolt mount		TE3607R	TE3607R	TE3606R	TE3606R						TE3607R - RHT M14x1.5 straight TE3606R - LHT M14x1.5 curved
10/68-9/73	E3 - 2500/2800/3.0				TE1786	TE1786	TE1787	TE1787						
9/72-5/81	E12 - 5 series		RH-BJ4222 LH-BJ4221		TE1786	TE1786	TE1788	TE1788			TR148			
6/75-83	E21 - 3 series				TE1785 M14x1.5 RHT	TE1785 M14x1.5 RHT			RH-RE3045 LH-RE3043					
2/76-5/82	E24 - 6 series				TE1786	TE1786	TE1788	TE1788			TR148			
5/77-86	E23 - 7 series				TE1786	TE1786	TE4204	TE4204		TE7212	TR4205			TE7212 consists of TE1786 x 1 & TE4204 x 1
78-4/89	E24 - 6 series				TE2234 RH Thread	TE2234 RH Thread	TE2233 LH Thread	TE2233 LH Thread			TR4228			
6/81-5/87	E28 - 5 series		RH - BJ9992 LH - BJ9991 inc. arm	bush only OEM3464K	TE2234 RH Thread	TE2234 RH Thread	TE2233 LH Thread	TE2233 LH Thread			TR4228			
10/82-on	E30 - 3 series		BJ997 LH/RH Inner BJ998 LH/RH Outer		TE2046	TE2046			RH-RE4305 LH-RE4303					
10/86-on	E32 - 7 series	RH-BJ1000			TE2234	TE2234	TE2233	TE2233			TR4316			

STEERING and SUSPENSION COMPONENTS

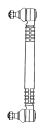

YEAR	MODEL	BALL JOINT UPPER 	BALL JOINT LOWER / KING PIN SET 	IDLER 	TIE ROD END L/H OUTER 	TIE ROD END R/H OUTER 	TIE ROD END L/H INNER 	TIE ROD END R/H INNER 	RACK END 	SIDE ROD 	CENTRE ROD 	DRAG LINK 	PITMAN 	NOTES/OTHER
------	-------	---	--	--	---	--	--	--	---	---	---	--	---	-------------

		LH-BJ999												
1988-on	E34 - 5 series NOT 518i	RH-BJ1098 LH-BJ1097 Torque Rods	RH-BJ1184 LH-BJ1185		TE2234	TE2234	TE2233	TE2233						TR4336 - not for 518i BJ1097/BJ1098 - "front axle upper thrust linkage" BJ1184/BJ1185 - "front axle lower track control arm with rubber mounting"
1988-on	E34 - 5 series - 518i ONLY	RH-BJ1098 LH-BJ1097 Torque Rods	RH-BJ1184 LH-BJ1185		TE2234	TE2234	TE2233	TE2233						TR4335 - for 518i only BJ1097/BJ1098 - "front axle upper thrust linkage" BJ1184/BJ1185 - "front axle lower track control arm with rubber mounting"
1989-on	E31 - 8 series				TE2234	TE2234	TE2233	TE2233						TR4338
11/90-on	E36 - 3 series		BJ1177 LH/RH Inner BJ1178 LH/RH Outer		TE4341	TE4344			RE4342					
1994-on	E38 - 7 series				TE4350	TE4351								













**B
U
I
C
K**

BUICK														
1938-42	Series 40, 50	SX4			TE175L	TE175L								
1942-49	Series 40, 50	SX4			TE52L	TE52L								
1949-50	Series 40, 50	SX4			TE52R	TE52R								
1938-52	Series 60, 70	SX13			TE175L	TE175L								
1953-56	Series 40, 50, 60, 70	SX13			TE52R	TE52R								
1941-52	Series 90	SX4			TE175L	TE175L								
	APOLLO, SKYLARK													
1964-72	Skylark, Special	BJ54	BJ55 or BJ55OS oversize	18799	TE52R	TE52R								
1973-74	Appollo, Skylark (RWD)	BJ54	BJ55 or BJ55OS oversize	18718	ES381R	ES381R								
1975-79	Appollo, Skylark (RWD)	10268	305-153		ES427R (std)	ES427R (std)								ES427R - 8.79"

**B
U
I
C
K**

STEERING and SUSPENSION COMPONENTS



YEAR	MODEL	BALL JOINT UPPER 	BALL JOINT LOWER / KING PIN SET 	IDLER 	TIE ROD END L/H OUTER 	TIE ROD END R/H OUTER 	TIE ROD END L/H INNER 	TIE ROD END R/H INNER 	RACK END 	SIDE ROD 	CENTRE ROD 	DRAG LINK 	PITMAN 	NOTES/OTHER
------	-------	--	---	--	--	---	---	---	--	--	--	---	---	-------------

					or ES441R (rally susp)	or ES441R (rally susp)								ES441R - 8.12"
	ELECTRA, LeSABRE, WILDCAT													
1971-76	Electra, LeSabre, Wildcat (RWD)	10268	10267	18765 (1973-76)	ES403R	ES403R	ES403L	ES403L						
1977-91	Electra, LeSabre Wildcat (RWD)	10268	305-153	18799	ES2019R	ES2019R	ES2020L	ES2020L						
	RIVIERA													
1963-70	Riviera		10198											
1971-76	Riviera	10268	10267		ES403R	ES403R	ES403L	ES403L						
1977-78	Riviera	10268	305-153		ES2019R	ES2019R	ES2020L	ES2020L						

C A D I L L A C

CADILLAC														
	DEVILLE, FLEETWOOD, BROUGHAM													
1961-69	Deville, Fleetwood Brougham	RH-10211N LH-10210N	10142											
1970-76	Deville, Fleetwood Brougham	RH-10211N LH-10210N	10286	18747										
1977-85	Deville, Fleetwood Brougham (RWD)	10268	305-153	18799	ES2019R	ES2019R	ES2020L	ES2020L						
1986-96	Fleetwood Brougham (RWD) Not Heavy Duty/Limo/Armoured Body	10268	305-153	18799	ES2019R	ES2019R	ES2020L	ES2020L						
1986-96	Fleetwood Brougham (RWD) Heavy Duty/Limo/Armoured Body	10268	10267	18799										
	SEVILLE													
1976-79	Seville	10268	305-153	18753	ES427R	ES427R								

C H E V R O L E T

CHEVROLET														
1964-72	Beaumont	BJ54	BJ55 or BJ55OS oversize											
	BEL AIR, IMPALA, etc.													
1955-57	Bel Air, Biscayne, Caprice, Impala	BJ70	BJ3		TE57L	TE57L	ES577	ES577						

STEERING and SUSPENSION COMPONENTS











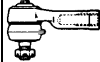

YEAR	MODEL	BALL JOINT UPPER	BALL JOINT LOWER / KING PIN SET	IDLER	TIE ROD END L/H OUTER	TIE ROD END R/H OUTER	TIE ROD END L/H INNER	TIE ROD END R/H INNER	RACK END	SIDE ROD	CENTRE ROD	DRAG LINK	PITMAN	NOTES/OTHER
------	-------	------------------	---------------------------------	-------	-----------------------	-----------------------	-----------------------	-----------------------	----------	----------	------------	-----------	--------	-------------

O
t

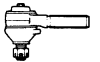
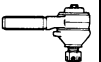
1958-62	Bel Air, Biscayne, Caprice, Impala	BJ70	BJ71	18753	310-151	310-151	ES597	ES597						
1963-64	Bel Air, Biscayne, Caprice, Impala	BJ70	BJ71	18753	310-154	310-154	ES597	ES597						
1965-66	Bel Air, Biscayne, Caprice, Impala	BJ70	BJ71	18672	310-171	310-171	310-182	310-182						
1967-68	Bel Air, Biscayne, Caprice, Impala	BJ70	BJ71	18703	310-171	310-171	310-182	310-182						
1969-70	Bel Air, Biscayne, Caprice, Impala	BJ70	BJ71	18703	ES378L	ES378L	ES378R	ES378R						
1971-76	Bel Air, Biscayne, Caprice, Impala	10268	10267	18765 (1973-76)	ES403R	ES403R	ES403L	ES403L						
1977-96	Bel Air, Biscayne, Caprice, Impala Not Police Car/Wagon	10268	305-153	18799	ES2019R	ES2019R	ES2020L	ES2020L						
1977-96	Bel Air, Biscayne, Caprice, Impala Police Car/Wagon	10268	10267	18799	ES2019R	ES2019R	ES2020L	ES2020L						
CAMARO														
1967-69	Camaro & Z28	BJ54	BJ55 or BJ55OS oversize	18718 1968-69	ES381R	ES381R							18770 p/steer 18768 m/steer	18770 - 5 7/8" stud centre to spline centre 18770 - power steer 1968-69; all 1967 18760 - manual steer excl. 302 engine
1970-74	Camaro & Z28	10268	305-153	18753	ES404R	ES404R	DS782	DS781					non wear	
1975-79	Camaro & Z28	10268	305-153	18753	ES441R	ES441R	ES442L	ES443L					non wear	
1980-81	Camaro & Z28 - 6 cylinder	10268	305-153	18753	ES427R	ES427R	ES2001L	ES2002L					non wear	
1980-81	Camaro & Z28 - V8	10268	305-153	18753	ES441R	ES441R	ES442L	ES443L					non wear	
1982-92	Camaro & Z28 with Mcpherson front strut suspension		305-153	18832	ES2226R	ES2226R	ES2227L	ES2227L					non wear	
1993-96	Camaro & Z28 with rack & pinion steering	104233	305-153		ES3238	ES3238								
CHEVELLE, etc.														
1964-72	Chevelle, El Camino, Malibu, & Monte Carlo	BJ54	BJ55 or BJ55OS oversize											

STEERING and SUSPENSION COMPONENTS



YEAR	MODEL	BALL JOINT UPPER 	BALL JOINT LOWER / KING PIN SET 	IDLER 	TIE ROD END L/H OUTER 	TIE ROD END R/H OUTER 	TIE ROD END L/H INNER 	TIE ROD END R/H INNER 	RACK END 	SIDE ROD 	CENTRE ROD 	DRAG LINK 	PITMAN 	NOTES/OTHER
------	-------	---	--	--	---	--	--	--	---	---	---	--	---	-------------

CORVETTE

1973-77	Chevelle, El Camino, Malibu, & Monte Carlo	10268	305-153		ES427R	ES427R									
1978-88	Chevelle, El Camino, Malibu, & Monte Carlo	10268	305-153	18799											
CORVETTE															
1963-82	Corvette	BJ70	BJ71		310-155	310-155	310-154	310-154							
1984-85	Corvette	10391	10413												
1986-96	Corvette	10391	10413		ES3239	ES3239									
NOVA															
1968-74	Nova, Chevy II (RWD), Acadian	BJ54	BJ55 or BJ55OS oversize	18718	ES381R	ES381R							18770 (1968-72 p/steer)		
1975-79	Nova, Chevy II (RWD)	10268	305-153	18753	ES441R	ES441R									

CHEVROLET - Commercial

1961-65	R1200 Truck & Bus	BJ70	BJ71												
C series 2WD inc. BLAZER															
1965-70	C10 2WD pickup, Blazer, Suburban			18573 (1965-66)	310-171	310-171	310-182	310-182						18755	
1971-72	C10 2WD pickup, Blazer, Suburban with Disc Brakes		10264 or 104112 (.003" over)												
1971-91	C10 2WD pickup, Blazer, Suburban	10269	10264 or 104112 (.003" over)	18680 (1973-82) 18830 (1983-91)	310-212	310-212	310-211	310-211						18755 p/steer	18680 - both pins same size 17mm BLD 18830 - pins different size 17 & 15mm BLD
1960-66	C20 - C30 2WD manual steer	10213	10187		ES358L	ES358R	ES358R	ES358L						18667	
1967-78	C20 - C30 2WD manual steer	10213	10187		ES358L	ES358R	ES358R	ES358L						18681	
1969-70	C20 - C30 2WD manual steer	10213	10187		ES358L	ES358R	ES358R	ES358L						18731	
1969-70	C20 - C30 2WD power steer	10213	10187		ES358L	ES358R	ES358R	ES358L						18732	

STEERING and SUSPENSION COMPONENTS













YEAR	MODEL	BALL JOINT UPPER	BALL JOINT LOWER / KING PIN SET	IDLER	TIE ROD END L/H OUTER	TIE ROD END R/H OUTER	TIE ROD END L/H INNER	TIE ROD END R/H INNER	RACK END	SIDE ROD	CENTRE ROD	DRAG LINK	PITMAN	NOTES/OTHER
------	-------	------------------	---------------------------------	-------	-----------------------	-----------------------	-----------------------	-----------------------	----------	----------	------------	-----------	--------	-------------

Chevrolet

1971-91	C20 2WD pickup, Blazer, Suburban - manual steer	305-117	305-114	18680 (1973-82) 18830 (1983-91)	310-212	310-212	310-211	310-211					315-109 (18754)	18680 - both pins same size 17mm BLD 18830 - pins different size 17 & 15mm BLD
1971-91	C20 2WD pickup, Blazer, Suburban - power steer	305-117	305-114	18680 (1973-82) 18830 (1983-91)	310-212	310-212	310-211	310-211					315-110 (18755)	18680 - both pins same size 17mm BLD 18830 - pins different size 17 & 15mm BLD
1971-91	C30 2WD pickup - manual steer	305-117	305-114		310-212	310-212	310-211	310-211					315-109 (18754)	
1971-91	C30 2WD pickup - power steer	305-117	305-114		310-212	310-212	310-211	310-211					315-110 (18755)	
1963-77	C50 - 4ton C60 - 5ton		300-209		310-160 5.84"	310-161 5.84"								King pin set 1.179" x 6.360"
1978-80	C50 - 4ton C60 - 5ton		300-209		310-271 4.93"	310-272 4.93"								King pin set 1.179" x 6.360"
1964-80	C60 7000lb axle		300-173		310-164 (1963-77)	310-165								King pin set 1.2495" x 7.880"
1963-66	C60 9000lb axle				310-115									
1993-96	C2500 (3/4 ton)			190142										
1989-96	3500 Pickup	104150		190142 - without bracket 190156 - with bracket									190121	
	K series 4WD inc. BLAZER													
1967-91	K20, V20 4WD pickup, Blazer, Suburban	305-112	10253											
1967-91	K25, V2500 4WD pickup, Suburban	305-112	10253											
1970-91	K10, V10 4WD pickup, Blazer, Suburban	305-112	10253											
1970-91	K15, V1500 4WD pickup, Suburban	305-112	10253											
	LUV													
1972-81	Chev Luv KB20, KB25	BJ201	BJ202		TE595L	TE595R				TR668		ends only		BJ201 - please specify if lock nut required

STEERING and SUSPENSION COMPONENTS

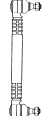
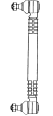

YEAR	MODEL	BALL JOINT UPPER 	BALL JOINT LOWER / KING PIN SET 	IDLER 	TIE ROD END L/H OUTER 	TIE ROD END R/H OUTER 	TIE ROD END L/H INNER 	TIE ROD END R/H INNER 	RACK END 	SIDE ROD 	CENTRE ROD 	DRAG LINK 	PITMAN 	NOTES/OTHER
------	-------	--	---	--	--	---	---	---	--	--	--	---	---	-------------

					Drag Link Tie Rod Ends								TE595L/R		TR668 - replacement for inner & outer tie rod ends
1981-85	Chev Luv KB21, KB26, KB27, KB28	BJ203	BJ204		TE596R	TE596R			RE846 female end				TR625 front		Front track rod - TR625

CHRYSLER (includes - Valiant) (see also Mitsubishi)

1975-80	Cordoba, LeBaron (USA)	BJ8													
1946-54	Royal Windsor, Saratoga, New Yorker (not 7 passenger)				TE49L	TE49R	TE49R	TE49L							
1957-64	Royal Sedan SP1,2,3 6-8cyl (Aust produced) Royal Station, Sedan & Utility				TE114L	TE114L									
1958-62	LC1-L,MC1-L,PC1-L,RC1-L,SC1-L, RC2-M,SC2-M	BJ8		SX1103											
CENTURA															
1975-78	Centura KB, KC		BJ119		TE474L	TE474L									TE474L - LHT M12x1
GALANT - see MITSUBISHI															
JEEP - see JEEP															
NEON															
1996-on	Neon		104178		TE3173	TE3173									
VALIANT															
1961-62	Valiant RV1	BJ18	BJ14	SX1116											Idler arm ball bearing kit - SX1103A
1962-2/66	Valiant SV1, AP5, AP6	BJ18	RH-BJ35 LH-BJ36	SX1116	TE173L	TE173R	TE173R	TE173L						SX2593 sourcing	BJ35/36 - 1/2" mount holes BJ80/81 - 9/16" mount holes Idler arm ball bearing kit - SX1103A
Typical Valiant type Front Suspension															
2/66-11/67	Valiant AP6 (late), VC no disc brake knuckle shield	BJ18	RH-BJ35 LH-BJ36	SX1116	TE173L	TE173R	TE173R	TE173L					K2427 sourcing	BJ35/36 - 1/2" mount holes BJ80/81 - 9/16" mount holes	

STEERING and SUSPENSION COMPONENTS

C H R Y S L E R



YEAR	MODEL	BALL JOINT UPPER	BALL JOINT LOWER / KING PIN SET	IDLER	TIE ROD END L/H OUTER	TIE ROD END R/H OUTER	TIE ROD END L/H INNER	TIE ROD END R/H INNER	RACK END	SIDE ROD	CENTRE ROD	DRAG LINK	PITMAN	NOTES/OTHER
------	-------	------------------	---------------------------------	-------	-----------------------	-----------------------	-----------------------	-----------------------	----------	----------	------------	-----------	--------	-------------

														Idler arm ball bearing kit - SX1103A
4/66-11/67	Valiant VC with disc brake knuckle shield	BJ18	RH-BJ80 LH-BJ81	SX1116	TE173L	TE173R	TE173R	TE173L						SX2427 Bushing BJ80/81 - 9/16" mount holes BJ35/36 - 1/2" mount holes Idler arm ball bearing kit - SX1103A
12/67-12/68	Valiant VE - with disc brake knuckle shield Manual steer	BJ18	RH-BJ80 LH-BJ81	SX1116	TE173L	TE173R	TE173R	TE173L						SX808 B900 BJ80/81 - 9/16" mount holes BJ35/36 - 1/2" mount holes Idler arm ball bearing kit - SX1103A
12/67-12/68	Valiant VE - with disc brake knuckle shield Power steer	BJ18	RH-BJ80 LH-BJ81	SX1116	TE173L	TE173R	TE173R	TE173L						SX808B B900B power steer Idler arm ball bearing kit - SX1103A
1968-9/77	Valiant VE, VF, VG, VH, VJ, CH, CJ, VK, CL Manual steer	BJ18	RH-BJ35 LH-BJ36	SX1116 (to 2/77)	TE173L	TE173R	TE173R	TE173L						SX808 (18900) manual steer Idler arm ball bearing kit - SX1103A
1968-9/77	Valiant VE, VF, VG, VH, VJ, CH, CJ, VK, CL Power steer	BJ18	RH-BJ35 LH-BJ36	SX1116 (to 2/77)	TE173L	TE173R	TE173R	TE173L						SX808B (18900B) power steer Idler arm ball bearing kit - SX1103A
10/77-1981	Valiant CM - Manual Steer	BJ18	RH-BJ35 LH-BJ36	SX1116CM	TE173L	TE173R	TE173R	TE173L						SX808 (18900) manual steer Original Idler Replacement Bush - 3885379
10/77-1981	Valiant CM - Power Steer	BJ18	RH-BJ35 LH-BJ36	SX1116CM	TE173L	TE173R	TE173R	TE173L						SX808B (18900B) power steer Original Idler Replacement Bush - 3885379
VOYAGER														
1997-on	Voyager - from USA		104178											

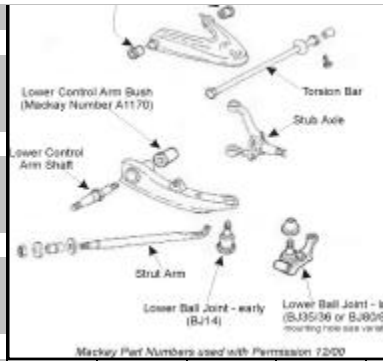

SPORTS

CITROEN														
7/1978-on	CX 2000, 2200, 2400 Normal Track		BJ8213											
1993-on	Xantia		BJ8039		TE4180	TE4280			RE6394					
1989-94	XM		BJ8039		TE7565	TE7465			RE2460					
1994-ON	XM	BJ4034			TE1741	TE1742			RE3812					
1997-on	Xsara - power steer		BJ4038		TE8175	TE8175			RE3812					BJ4038 - power steer & turbo diesel
1997-on	Xsara - manual steer		BJ4039		TE8175	TE8175			RE3812					BJ4039 - manual steer
COBRA REPLICA														
1985-on	Cobra 5.0 ltr Sports	BJ154	BJ155		TE525R	TE525R								

STEERING and SUSPENSION COMPONENTS

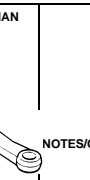
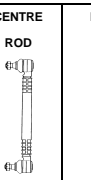
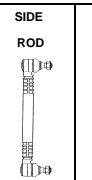
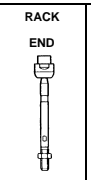
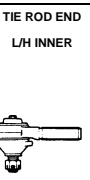
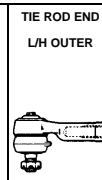
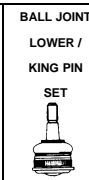

YEAR	MODEL	BALL JOINT UPPER	BALL JOINT LOWER / KING PIN SET	IDLER	TIE ROD END L/H OUTER	TIE ROD END R/H OUTER	TIE ROD END L/H INNER	TIE ROD END R/H INNER	RACK END	SIDE ROD	CENTRE ROD	DRAG LINK	PITMAN	NOTES/OTHER
------	-------	------------------	---------------------------------	-------	-----------------------	-----------------------	-----------------------	-----------------------	----------	----------	------------	-----------	--------	-------------

as manufactured by "The Replica Motor Co." Western Australia

COMMERCIAL

	COMMER													
1949-62	"R" series R541/715/741/762 & "C" series C715/741/762, CD715/741/762, CDY715/741/762, CX715/741/762, CY715/741/762, 5-7 ton; Avenger Passenger C510, CD510, C589, CD589, HD510, HDY510		KX162		TE366R	TE366L							TE367R	
1951	"S" series		KX41		TE72R	TE72L								
1952-55	"T" series		KX41		TE72R	TE72L								
1956-65	"B" series		KX41		TE72R	TE72L								
1958-65	"CA" & "CB" series - 10-12 ton		KX162		TE366R	TE366L							TE367R	
1961-65	"CA" & "CB" series - 8 ton		KX227		TE366R	TE366L							TE367R	
1962-65	"CA" & "CB" series - 7 ton		KX162		TE366R	TE366L							TE367R	
1963-66	"VA" series - 7 ton		KX162		TE366R	TE366L							TE367R	
1963-67	"VA" series - 8 ton (to chassis # VB702655)		KX227										TE367R	TE367R - to chassis# 702620
1965-68	"CC" series - 7 & 12 ton		KX162		TE366R	TE366L							TE367R	
1965-68	"CC" series - 8 ton (to chassis # 702196)		KX227		TE366R	TE366L							TE367R	TE367R - to chassis# 702620
1966-67	"VB" series - 7 ton (to chassis # 702659)		KX162										TE367R	TE367R - to chassis# 704458
1962-81	1500 van 15cwt / 2500 van 25cwt Series I,II,IIA,III,IV,PA,PB		KX199		TE125R	TE125L	TE125L	TE125R			RH-TE125L LH-TE125R	TE125R front TE125L rear		King pin set .812" x 4.750" Upper inner control arm kit - SX1066A
1957-63	Cob Series I, 11 8 cwt	BJ30	KX185											Upper inner control arm kit - SX1024A Lower inner control arm kit - SX1078A
1962-65	Cob Series III 8cwt	BJ31	BJ32		TE125L	TE125L	TE125R	TE125R						
1970-81	18cwt 2000 series		KX199		TE125R	TE125L	TE125L	TE125R			RH-TE125L LH-TE125R	TE125R front TE125L rear		King pin set .812" x 4.750"













COMMERCIAL

DAEWOO

	DAEWOO													
1994-6/98	1.5i, Cielo		BJ800		TE951	TE950								

STEERING and SUSPENSION COMPONENTS



YEAR	MODEL	BALL JOINT UPPER 	BALL JOINT LOWER / KING PIN SET 	IDLER 	TIE ROD END L/H OUTER 	TIE ROD END R/H OUTER 	TIE ROD END L/H INNER 	TIE ROD END R/H INNER 	RACK END 	SIDE ROD 	CENTRE ROD 	DRAG LINK 	PITMAN 	NOTES/OTHER
------	-------	--	---	--	--	---	---	---	--	--	--	---	---	-------------

e
w
o

3/95-6/97	Espero		BJ800		TE951	TE950									
1999-on	Lanos				TE951	TE950									
8/97-on	Leganza		BJ5809		TE9753	TE9753									RE898 - RHT M14x1.5 male
	MUSSO - see SSANYONG														
7/97-on	Nubira		BJ648		TE9753	TE9753			RE672						RE672 - RHT M16x1.5 female
1999-on	Matiz														

D
a
i
h
a
t
s
u

DAIHATSU															
	APPLAUSE														
1989-92	Applause A101 - manual steer				TE723L RH thread	TE723R RH thread			RE966						
1989-92	Applause A101 - power steer				TE723L RH thread	TE723R RH thread			RE967						
4/92-on	Applause B101 - manual steer				TE952	TE952			RE966						
4/92-on	Applause B101 - power steer				TE952	TE952			RE967						
	CHARADE														
1977-10/82	Charade G10		RH-BJ402R LH-BJ402L		TE684R	TE684R			RE840 male end						
1982-86	Charade G11 - ball joint & control arm		BJ4208		TE685L RH thread	TE685R RH thread			RE841 male end						TE685L & R = right hand thread
1/87-89	Charade G100,G101,G102 - ball joint & control arm - manual steer		RH-BJ4210 LH-BJ4211		TE723L RH thread	TE723R RH thread			RE870 male end						TE723L & R = right hand thread
1989-93	Charade G100,G101,G102 - ball joint & control arm - manual steer		RH-BJ4210 LH-BJ4211		TE723L RH thread	TE723R RH thread			RE969						TE723L & R = right hand thread
5/93-on	Charade G200,G203 - manual steer				TE723L RH thread	TE723R RH thread			RE969						
5/93-on	Charade G200,G203 - power steer				TE723L RH thread	TE723R RH thread			RE968						
	CUORE														

D
a
i
h
a
t
s
u

STEERING and SUSPENSION COMPONENTS



YEAR	MODEL	BALL JOINT UPPER	BALL JOINT LOWER / KING PIN SET	IDLER	TIE ROD END L/H OUTER	TIE ROD END R/H OUTER	TIE ROD END L/H INNER	TIE ROD END R/H INNER	RACK END	SIDE ROD	CENTRE ROD	DRAG LINK	PITMAN	NOTES/OTHER
------	-------	------------------	---------------------------------	-------	-----------------------	-----------------------	-----------------------	-----------------------	----------	----------	------------	-----------	--------	-------------

1999-on	Cuore		BJ7208		TE872	TE873			RE8721					
	MIRA													
4/90-on	Mira L102, L200, L300 2WD		BJ7208		TE872	TE873			RE8721					
	PYZAR													
1999-on	Pyzar													
	SIRION													
1998-on	Sirion													

DAIHATSU - Commercial

	DELTA													
1970-on	Delta 1500,2000,DV20L		KX704											
1973-77	Delta SV17,SV18		KX273											King pin set 25 x 155mm
1973-77	Delta SV23,SV26,DV23,DV26,DV28		KX273		TE599L	TE599R								King pin set 25 x 155mm
1977-84	Delta V10,V20,V30,V40,V50,V110 (Series)		KX274		TE600L	TE600R								King pin set 28 x 165mm
9/84-on	Delta V50,V70,V90 (Series) - manual steer				TE600L	TE600R					TR7320			manual steer
9/84-on	Delta V50,V70,V90 (Series) - power steer				TE686L	TE686R					TR7320			power steer
	F series inc. ROCKY													
1977-84	F Series & Rocky F20,F25,F50,F60,F65				TE712	TE600R								
1984-87	F Series & Rocky F70,F75,F80,F85				TE712	TE600R					TR647			
1987-on	F Series & Rocky F70,F73,F75,F77,F78						TE959	TE959						
10/88-5/98	Feroza F300 I, II, III	BJ5680	BJ3680	SX7601	TE955	TE954	TE958	TE953					SX7605	
	HANDI-VAN													

STEERING and SUSPENSION COMPONENTS



YEAR	MODEL	BALL JOINT UPPER	BALL JOINT LOWER / KING PIN SET	IDLER	TIE ROD END L/H OUTER	TIE ROD END R/H OUTER	TIE ROD END L/H INNER	TIE ROD END R/H INNER	RACK END	SIDE ROD	CENTRE ROD	DRAG LINK	PITMAN	NOTES/OTHER
------	-------	------------------	---------------------------------	-------	-----------------------	-----------------------	-----------------------	-----------------------	----------	----------	------------	-----------	--------	-------------

C 5 - 2

	HIJET													
1968-76	Hijet Van S37,L37,S38,S40	RH-BJ253R LH-BJ253L	RH-BJ254R LH-BJ254L		TE687L	TE687R	TE687R	TE687L						
1979-1/83	Hijet Van S10, S70	RH-BJ253R LH-BJ253L	RH-BJ256R LH-BJ256L		TE687L	TE687R	TE687R	TE687L						
1976-4/81	Hijet Van S38,S40,S60	RH-BJ253R LH-BJ253L	RH-BJ255R LH-BJ255L		TE687L	TE687R	TE687R	TE687L						
4/81-86	Hijet Van S65	RH-BJ253R LH-BJ253L	RH-BJ255R LH-BJ255L		TE688L	TE688R	TE688L	TE688R						
4/81-90	Hijet Van S70,S75,S80,S85				TE688L	TE688R	TE688L	TE688R						
	TERIOS													
1998-on	Terios 4WD													

DAIMLER - see JAGUAR

DANA/SPICER AXLES













FRONT AXLE MODEL # IDENTIFICATION														
The tag to identify the front non-drive steering axles is located between the spring pads on the front side of the centre beam section.														
I-50 (5,000lbs), I-60 (6,000 lbs), I-75 (7,500lbs) I-80 (8,000lbs)		300-218		310-183	310-184									King pin set with metal bushes 1.359" x 7.970"
I-90 (9,000lbs) Tie rod ends for straight I-Beam axle only				310-215	310-216									Tie rod end - 9.18" stud centre to end
I-108 (10,800lbs), I-120 (12,000lbs), I-132 (13,200lbs) Tie rod ends for straight I-Beam axle only		300-249		310-215	310-216									Twin keyway king pin set with metal bushes - 1.61" x 9.660"

DATSUN - see NISSAN

DE SOTO														
1941-52	Custom S8C,S10C,S11C, Deluxe S8S,S10S, S11S (not 7 passenger sedan, limo &		KX22		TE49L	TE49R	TE49R	TE49L						Upper inner control arm - SX1012A

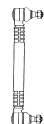
STEERING and SUSPENSION COMPONENTS



YEAR	MODEL	BALL JOINT UPPER 	BALL JOINT LOWER / KING PIN SET 	IDLER 	TIE ROD END L/H OUTER 	TIE ROD END R/H OUTER 	TIE ROD END L/H INNER 	TIE ROD END R/H INNER 	RACK END 	SIDE ROD 	CENTRE ROD 	DRAG LINK 	PITMAN 	NOTES/OTHER
------	-------	--	---	--	--	---	---	---	--	--	--	---	---	-------------

	S11S wagon)													
1953-57	Diplomat S7U,SP25 series manual steer		KX21	SX1040	TE423L	TE423L								Upper inner control arm - SX1012A SX1040 - Idler arm support kit
1948-50	SA108, SB108, SA226 3/4-1 ton		KX23		TE49L	TE49R						TE49L & R ends only		King pin set - .795" x 5 3/8"
1948-56	64, 64P4, 65P4, 86P6, 87P6, 88P6, 103, 103P6, 105P6, 106P6, 123, 124, 125, 126, 134, 2-6ton		KX76		TE72R	TE72L						TE72L & R ends only		
1950-58	SB226, SC226, 226AS/BS/CS, 233AS, BS, 25-30 cwt SC108, 108AS, 108BS/CS/DS, 15 cwt		KX90		TE49L	TE49R						TE49L & R ends only		King pin set - .8725" x 5 3/8"
1953-58	359AS/BS, 671AS/BS, 865AS/BS, 871AS/BS, 2 1/2-6 ton 203/205/223/225/264, 2-6 ton		KX76		TE72R	TE72L						TE72L & R ends only		

DODGE

DODGE														
CHARGER, CORONET														
1955-78	Charger, Coronet	BJ8			TE173R	TE173R	TE173L	TE173L						
CHALLENGER etc.														
1962-78	Challenger, Charger, Magnum, Crestwood Super Bee, Monaco, Polara etc.	BJ8												
DART														
1960-62	Dart SD1, SD2	BJ8			TE173R	TE173R	TE173L	TE173L						
1963-72	Dart - all models	BJ18			TE173R (to 1969)	TE173R (to 1969)	TE173L (to 1969)	TE173L (to 1969)						
1973-79	Dart, Aspen, Swinger	BJ8												
DIPLOMAT, MONACO														
1976-89	Diplomat, Monaco, St.Regis (not Royal)	BJ8												
PHOENIX														
1963-65	Phoenix TD2, VD2	BJ8	RH - BJ1303 LH - BJ1304		TE173R	TE173R	TE173L	TE173L						
1965-73	Phoenix AP2,DB6,DC6,DD6,DE6,DF6,DG6	BJ8	RH - BJ1303 LH - BJ1304		TE173R	TE173R	TE173L	TE173L						

DODGE - Commercial

STEERING and SUSPENSION COMPONENTS

YEAR	MODEL	BALL JOINT UPPER	BALL JOINT LOWER / KING PIN SET	IDLER	TIE ROD END L/H OUTER	TIE ROD END R/H OUTER	TIE ROD END L/H INNER	TIE ROD END R/H INNER	RACK END	SIDE ROD	CENTRE ROD	DRAG LINK	PITMAN	NOTES/OTHER
------	-------	------------------	---------------------------------	-------	-----------------------	-----------------------	-----------------------	-----------------------	----------	----------	------------	-----------	--------	-------------

DODGE

1994-on	Dodge Ram 2500, 3500 4WD Pickup with Dana 44 axle	305-112	10253											
1994-on	Dodge Ram 2500, 3500 4WD Pickup with Dana 60 axle	305-126												
DODGE TRUCK														
1941-52	D19,D22,D24,D30,D31,D32,D34,D36,D39,D40,D42,Way Farer D29,D33,D41				TE49L	TE49R	TE49R	TE49L						
1953-57	Kingsway D43-1,D49-1,D49-2 (Australian Models) Manual Steer Only					TE114L	TE114L							
1957-58	Utility D49A-2 serial# 436 on (also 347-365 inc.) D49A-3 series# 98 on; series# 28 on					TE114L	TE114L							
1957-77	C600,D600,L600,S600,C700,CT700,D700,DC700,L700,C800,CT800,D800,C850,C900,VL900,VL900,LNT900,LV900,C1000 with 7000lb axle	300-140			310-142 LH thread	310-143 RH thread								Twin keyway king pin set with metal bushes - 1.234" x 7.440"
1962-73	AT4-114,129,229,329,353 1-3 ton	300-112			TE175L	TE175R								King pin set with metal bushes 0.8605" x 5.440"
1962-73	AT4-460,475,500,560,575,660,675,690 4, 5, 6 ton with 5000lb axle	300-135			310-282 LH thread	310-281 RH thread								King pin set with metal bushes 1.124" x 7.250"
1962-73	AT4-660H,660HD,675H,675HD,690H,690HD,760,760D,775,775D, 6-7 ton with 7000lb axle	300-140			310-142 LH thread	310-143 RH thread								Twin keyway king pin set with metal bushes - 1.234" x 7.440"
1973-77	D5N - 200 & 300 series 2160, 2180, 2260, 2280 & 3260, 3280, 3560, 3580	KX840			TE175L	TE175R								Single keyway king pin set 25mm x 138mm
1973-77	D5N - 400 & 500 series 466, 468, 478, 566, 568, 576, 578 56D, DF3-650 3-5 ton with 5000lb axle	300-135			TE175L	TE175R								Twin keyway king pin set with metal bushes - 1.124" x 7.250"
6/79	Dodge 700 series 13,200kg		KX244											Stepped King Pin
1966-77	Utility 106C series VE,VF,VJ,VH-E-20,VS,VK	BJ18	RH-BJ35 LH-BJ36	SX1116	TE173L	TE173R	TE173R	TE173L						Idler arm ball bearing kit - SX1103A

STEERING and SUSPENSION COMPONENTS



YEAR	MODEL	BALL JOINT UPPER	BALL JOINT LOWER / KING PIN SET	IDLER	TIE ROD END L/H OUTER	TIE ROD END R/H OUTER	TIE ROD END L/H INNER	TIE ROD END R/H INNER	RACK END	SIDE ROD	CENTRE ROD	DRAG LINK	PITMAN	NOTES/OTHER
------	-------	------------------	---------------------------------	-------	-----------------------	-----------------------	-----------------------	-----------------------	----------	----------	------------	-----------	--------	-------------

1966-68	Utility 106C VE-E-20 (with disc brakes & combination of steering knuckle, adaptor & shield)	BJ18	RH-BJ80 LH-BJ81	SX1116	TE173L	TE173R	TE173R	TE173L						Idler arm ball bearing kit - SX1103A
---------	---	------	--------------------	--------	--------	--------	--------	--------	--	--	--	--	--	--------------------------------------

EUNOS - see MAZDA

F
i
a
t

FIAT														
1953-69	1100-103/D/E/G/H,Riveria, 1200, 1500L, 1800/B, 2100				TE149R	TE149L								
7/66 - 1/73	124 series I	BJ1765	BJ1766		TE1164	TE1164	TE1190	TE1190						
2/73-2/76	124 series II	BJ1765	BJ1766		TE1164	TE1164	TE1477	TE1477						
1961-73	125	BJ72	BJ157		TE400R	TE400R	TE400L	TE400L						
1963-67	1300, 1500	BJ72	BJ121		TE400R	TE400R								
1963-69	500D/E/F chassis # 575440-on; 600E, 770				TE395L	TE395L	TE399R	TE399R			TR398			
1964-72	850 series				TE395L	TE395L	TE397R	TE396R			TR398			
1966-76	124 sedan, Special Coupe, Spyder	BJ121	BJ73		TE395L	TE395L	TE399R	TE399R			TR398			
1966-76	Sports	BJ121	BJ73		TE395L	TE395L	TE399R	TE396R			TR398			
1973-75	128				TE532R	TE532R								
1970-76	130				TE400R	TE400R								
1976-81	131, Mirafiori, Supermirafiori		BJ2018 arm inc. bushes		TE3637R	TE3637R								
1981-12/86	131 Superbrava		BJ2018 arm inc. bushes											
4/72-85	132, Argenta	BJ72	BJ157		TE400R	TE400R	TE400L	TE400L						
4/83-90	Regata 100S (16L) - manual steer				TE1837	TE1837			RE2027					RE2027 - 275mm
6/83-90	Regata 100S (16L) - power steer				TE1837	TE1837			RE4086					RE4086 - 215mm

TIE ROD END SELECTION
 Inner & Outer Tie Rod End Selection: NOTE - there is a threaded connecting tube for inner & outer tie rod ends - if this is reversed the tie rod end threads will appear to be incorrect. Please ensure the connecting tubes are in the correct orientation prior to selecting tie rod ends.

F
O
R

FORD														
1957-59	All USA Models (Except Thunderbird)	BJ1	BJ2		310-220	310-220								

STEERING and SUSPENSION COMPONENTS

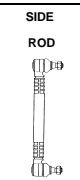
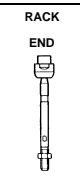
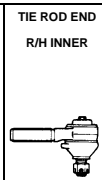
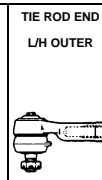
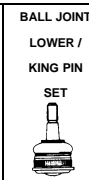

YEAR	MODEL	BALL JOINT UPPER	BALL JOINT LOWER / KING PIN SET	IDLER	TIE ROD END L/H OUTER	TIE ROD END R/H OUTER	TIE ROD END L/H INNER	TIE ROD END R/H INNER	RACK END	SIDE ROD	CENTRE ROD	DRAG LINK	PITMAN	NOTES/OTHER
------	-------	------------------	---------------------------------	-------	-----------------------	-----------------------	-----------------------	-----------------------	----------	----------	------------	-----------	--------	-------------

R

1969-73	CAPRI Capri - 1.6lt 4cyl & 3.0lt V6 Deluxe GT, XL, 3000 GT 2 door coupe one piece lower arm/ball joint		RH-BJ124 LH-BJ125		TE406R	TE406R								
10/89-7/94	Capri SA,SB,SC,SE front wheel drive with manual steer		BJ330		TE3624R	TE3624R			CGR-RE891 VGR-RE892					CGR rack has constant gear ratio VGR rack has variable gear ratio
10/89-7/94	Capri SA,SB,SC,SE front wheel drive with power steer		BJ330		TE3624R	TE3624R			RH-RE893R LH-RE894L					

F

1963-70	CONSUL / CORSAIR Consul, Corasir		BJ5216RK (repair kit) RH-BJ40 LH-BJ41 (NLA)	SX1084	TE171L	TE171R	TE171R	TE171L						BJ5216RK repair kit is used to rebuild ball joint assy's which are equipped with full ball type ball studs. In cases where assy's are equipped with 1/2 ball type ball studs BJ40 or BJ41 assy (according to side) must be used, after which BJ5216RK can be used for future rebuilding. BJ40/41 - ball joint assy's with 3/8"(10mm) diameter mounting attachment holes
1966-70	Consul		BJ142	SX1266 SX1266RK - idler repair kit	TE403R	TE403R	TE405L	TE404L						Lower inner control arm kit - SX1048A
1971-73	Consul, Granada	BJ144	BJ143		TE422R	TE422R			RE902					
1986-on	Corsair - all models TRW rack		BJ286		TE739 14mm thread	TE739 14mm thread			P191013 14mm thread					
1986-on	Corsair - all models Japanese rack		BJ555		TE2225 12mm thread	TE2225 12mm thread			RE857 12mm thread					

1962-67	CORTINA Cortina MKI 1200,1500 CB,CE,GT,GT500 (not Lotus Cortina)		BJ5216RK (repair kit) RH-BJ40 LH-BJ41 (NLA)	SX1084	TE171L	TE171R	TE171R	TE171L				Drag Link Bush Kit OEM0429K (MKI - 63-65)		BJ5216RK repair kit is used to rebuild ball joint assy's which are equipped with full ball type ball studs. In cases where assy's are equipped with 1/2 ball type ball studs BJ40 or BJ41 assy (according to side) must be used, after which BJ5216RK can be used for future rebuilding. BJ40/41 - ball joint assy's with 3/8"(10mm)
---------	---	--	---	--------	--------	--------	--------	--------	--	--	--	--	--	---

STEERING and SUSPENSION COMPONENTS



YEAR	MODEL	BALL JOINT UPPER	BALL JOINT LOWER / KING PIN SET	IDLER	TIE ROD END L/H OUTER	TIE ROD END R/H OUTER	TIE ROD END L/H INNER	TIE ROD END R/H INNER	RACK END	SIDE ROD	CENTRE ROD	DRAG LINK	PITMAN	NOTES/OTHER
------	-------	------------------	---------------------------------	-------	-----------------------	-----------------------	-----------------------	-----------------------	----------	----------	------------	-----------	--------	-------------

														diameter mounting attachment holes
1967-71	Cortina MkII 1300,1500,1600 CD L series one piece lower arm/ball joint		BJ142	SX1266 SX1266RK - idler repair kit	TE403R	TE403R	TE405L	TE404L			TE1509RK	Drag Link Bush Kit OEM1449K		TE1509RK - repair kit only Idler or Pitman Arm Bush Kit - SX1266RK
1971-77	Cortina TC,TD	BJ144	BJ143		TE422R	TE422R			RE902					
1977-82	Cortina TE,TF	BJ123	BJ152		TE524R	TE524R			RE903 manual steer RE6412 power steer					
CUSTOMLINE														
1952-54	Customline, Maimline 2A, 3A, 4A		KX28		TE107L	TE107L	TE108R	TE108R						Upper inner control arm kit - SX1014
1955-59	Customline, Maimline BN, BJ	BJ1	BJ2	SX1075	TE86L	TE86L								
ESCAPE														
2001-02	Escape		BJ4170		TE4170	TE4170			TE4170					
ESCORT														
1954-63	Escort - English (Anglia, Prefect, Squire, Popular)		RH-BJ51 LH-BJ52	SX1086	TE118L	TE118R	TE118R	TE118L						SX1086 - idler arm repair kit
9/68-3/75	Escort MKI - 1100,1300,1500,1600 one piece lower arm/ball joint		RH-BJ124 LH-BJ125		TE406R	TE406R			RE710					BJ124/125 Arm & Joint
6/75-7/80	Escort MKII - 1600,1800,2000 one piece lower arm/ball joint		RH-BJ124 LH-BJ125		TE422R	TE422R			RE904 or RE710	Note - Outer Rod End Thread Difference RE904 versus RE710 RE904 Course Thread - 14 x 2 RE710 Fine Thread - 1/2" x 20 tpi			BJ124/125 Arm & Joint	
FAIRLANE														
1962-65	Fairlane Compact FB,FC,FD	BJ34 or BJ34ARM (inc. arm)												
1966-67	Fairlane ZA Outer tie rod ends longer than inners	BJ34 or	BJ74 or	SX1117	TE414R 250mm long	TE414R 250mm long	TE390L 135mm long	TE390L 135mm long					XW3590A manual	Spring saddle (rubber) - XR3388A (single) Spring saddle (urethane) - OEM335K (pair)

FOR

STEERING and SUSPENSION COMPONENTS



YEAR	MODEL	BALL JOINT UPPER	BALL JOINT LOWER / KING PIN SET	IDLER	TIE ROD END L/H OUTER	TIE ROD END R/H OUTER	TIE ROD END L/H INNER	TIE ROD END R/H INNER	RACK END	SIDE ROD	CENTRE ROD	DRAG LINK	PITMAN	NOTES/OTHER
------	-------	------------------	---------------------------------	-------	-----------------------	-----------------------	-----------------------	-----------------------	----------	----------	------------	-----------	--------	-------------

		BJ34ARM (inc. arm)	BJ74ARM (inc. arm)											steer only	Upper inner control arm kit - SX1118A Shackle Kit (Rear Hanger) - SK6871
1966-67	Fairlane ZA Outer tie rod ends shorter than inners	BJ34 or BJ34ARM (inc. arm)	BJ74 or BJ74ARM (inc. arm)	SX1117	TE391R 120mm long Ball stud 7/16" dia. thread	TE391R 120mm long Ball stud 7/16" dia. thread	TE415L 275mm long Ball stud 7/16" dia. thread	TE415L 275mm long Ball stud 7/16" dia. thread						XW3590A manual steer only	Spring saddle (rubber) - XR3388A (single) Spring saddle (urethane) - OEM335K (pair) Upper inner control arm kit - SX1118A Shackle Kit (Rear Hanger) - SK6871
1968-69	Fairlane ZB,ZC	BJ34 or BJ34ARM (inc. arm)	BJ75	SX1117	TE391R 120mm long Ball stud 7/16" dia. thread	TE391R 120mm long Ball stud 7/16" dia. thread	TE415L 275mm long Ball stud 7/16" dia. thread	TE415L 275mm long Ball stud 7/16" dia. thread						XW3590A manual steer only	Spring saddle (rubber) - XR3388A (single) Spring saddle (urethane) - OEM335K (pair) Upper inner control arm kit - SX1118A Shackle Kit (Rear Hanger) - SK6871
1969-72	Fairlane ZC,ZD	BJ34 or BJ34ARM (inc. arm)	BJ75	SX1117	TE420R Ball stud 1/2" dia. thread	TE420R Ball stud 1/2" dia. thread	TE421L Ball stud 1/2" dia. thread	TE421L Ball stud 1/2" dia. thread						XW3590A manual steer only	Spring saddle (rubber) - XR3388A (single) Spring saddle (urethane) - OEM335K (pair) Upper inner control arm kit - SX1118A Shackle Kit (Rear Hanger) - SK6871
1972-79	Fairlane ZF,ZG,ZH & LTD - manual steer	BJ94	BJ75 or BJ75ARM (inc. arm)	SX1119 or SX1119U or OEM644K	TE420R Ball stud 1/2" dia. thread	TE420R Ball stud 1/2" dia. thread	TE421L Ball stud 1/2" dia. thread	TE421L Ball stud 1/2" dia. thread	** NOTE - BJ75ARM does not come with bushes. Bushes are available - please specify your requirement when ordering. Up to 5/80 XD use BJ75B12 bush; 6/80-on (XD-on) use BJ75B14 bush.				SX809 (18901)	Spring saddle (rubber) - XR3388A (single) Spring saddle (urethane) - OEM335K (pair) Upper inner control arm kit - SX1118A SX1119 - rubber bushes' both ends SX1119U - rubber/urethane combination OEM644K - urethane bushes' both ends Shackle Kit (Rear Hanger) - SK6871	
1972-79	Fairlane ZF,ZG,ZH & LTD - power steer	BJ94	BJ75 or BJ75ARM (inc. arm)	SX1119 or SX1119U or OEM644K	TE420R Ball stud 1/2" dia. thread	TE420R Ball stud 1/2" dia. thread	TE421L Ball stud 1/2" dia. thread	TE421L Ball stud 1/2" dia. thread	** NOTE - BJ75ARM does not come with bushes. Bushes are available - please specify your requirement when ordering. Up to 5/80 XD use BJ75B12 bush; 6/80-on (XD-on) use BJ75B14 bush.				SX809B (18902)	Spring saddle (rubber) - XR3388A (single) Spring saddle (urethane) - OEM335K (pair) Upper inner control arm kit - SX1118A SX1119 - rubber bushes' both ends SX1119U - rubber/urethane combination OEM644K - urethane bushes' both ends Shackle Kit (Rear Hanger) - SK6871	
1979-2/88	Fairlane ZJ,ZK,ZL,LTD - manual steer	BJ94	BJ75 or BJ75ARM (inc. arm)	SX1119 or SX1119U or OEM644K	TE548R	TE548R	TE549L	TE549L	** NOTE - BJ75ARM does not come with bushes. Bushes are available - please specify your requirement when ordering. Up to 5/80 XD use BJ75B12 bush; 6/80-on (XD-on) use BJ75B14 bush.				SX809 (18901)	Spring saddle (rubber) - XR3388A (single) Spring saddle (urethane) - OEM335K (pair) Upper inner control arm kit - SX1146A SX1119 - rubber bushes' both ends SX1119U - rubber/urethane combination OEM644K - urethane bushes' both ends	
1979-2/88	Fairlane ZJ,ZK,ZL,LTD - power steer	BJ94	BJ75 or	SX1119 or	TE548R	TE548R	TE549L	TE549L	** NOTE - BJ75ARM does not come with bushes. Bushes are available - please specify your				SX809B (18902)	Spring saddle (rubber) - XR3388A (single) Spring saddle (urethane) - OEM335K (pair)	

F O R D

STEERING and SUSPENSION COMPONENTS



YEAR	MODEL	BALL JOINT UPPER	BALL JOINT LOWER / KING PIN SET	IDLER	TIE ROD END L/H OUTER	TIE ROD END R/H OUTER	TIE ROD END L/H INNER	TIE ROD END R/H INNER	RACK END	SIDE ROD	CENTRE ROD	DRAG LINK	PITMAN	NOTES/OTHER
------	-------	------------------	---------------------------------	-------	-----------------------	-----------------------	-----------------------	-----------------------	----------	----------	------------	-----------	--------	-------------

			BJ75ARM (inc. arm)	SX1119U or OEM644K										requirement when ordering. Up to 5/80 XD use BJ75B12 bush; 6/80-on (XD-on) use BJ75B14 bush.	Upper inner control arm kit - SX1146A SX1119 - rubber bushes' both ends SX1119U - rubber/urethane combination OEM644K - urethane bushes' both ends
1973-76	Landau - manual steer	BJ94	BJ75 or BJ75ARM (inc. arm)	SX1119 or SX1119U or OEM644K	TE548R	TE548R	TE549L	TE549L	* NOTE - BJ75ARM does not come with bushes. Bushes are available - please specify your requirement when ordering. Up to 5/80 XD use BJ75B12 bush; 6/80-on (XD-on) use BJ75B14 bush.			SX809 (18901)	Spring saddle (rubber) - XR3388A (single) Spring saddle (urethane) - OEM335K (pair) Upper inner control arm kit - SX1146A SX1119 - rubber bushes' both ends SX1119U - rubber/urethane combination OEM644K - urethane bushes' both ends		
1973-76	Landau - power steer	BJ94	BJ75 or BJ75ARM (inc. arm)	SX1119 or SX1119U or OEM644K	TE548R	TE548R	TE549L	TE549L	* NOTE - BJ75ARM does not come with bushes. Bushes are available - please specify your requirement when ordering. Up to 5/80 XD use BJ75B12 bush; 6/80-on (XD-on) use BJ75B14 bush.			SX809B (18902)	Spring saddle (rubber) - XR3388A (single) Spring saddle (urethane) - OEM335K (pair) Upper inner control arm kit - SX1146A SX1119 - rubber bushes' both ends SX1119U - rubber/urethane combination OEM644K - urethane bushes' both ends		
1988-8/89	Fairlane NA,LTD DA	BJ296	BJ292 or BJ292OS (oversize)		TE731 14mm thread	TE731 14mm thread			P191010 (RE817)					14mm Tie rod ends/Rack	
8/89-2/95	Fairlane NA,NC,LTD DA,DC	BJ296	BJ292 or BJ292OS (oversize)		TE732 16mm thread	TE732 16mm thread			P191017 (RE818)					16mm Tie rod ends/Rack	
3/95-on	Fairlane NF,LTD DF	BJ296	BJ292 or BJ292OS (oversize)		TE732 16mm thread	TE732 16mm thread			P191041 6mm shorter than P191017					16mm Tie rod ends/Rack	
	FALCON														
1960-61	Falcon XK - to Chassis # 4R1-62-66654 & 4B1-62-34	BJ10	BJ11	idler bush OEM0936K 29mm OD bush or OEM1006K 33mm OD bush	TE163R	TE163R	TE163L	TE163L			TR304	TR304			
1961-63	Falcon XK - from Chassis # 4R1-62-6655	BJ10	BJ39	idler bush	TE163R	TE163R	TE163L	TE163L			TR304	TR304		BJ39ARM - 15 3/4" long	

STEERING and SUSPENSION COMPONENTS



YEAR	MODEL	BALL JOINT UPPER	BALL JOINT LOWER / KING PIN SET	IDLER	TIE ROD END L/H OUTER	TIE ROD END R/H OUTER	TIE ROD END L/H INNER	TIE ROD END R/H INNER	RACK END	SIDE ROD	CENTRE ROD	DRAG LINK	PITMAN	NOTES/OTHER
------	-------	------------------	---------------------------------	-------	-----------------------	-----------------------	-----------------------	-----------------------	----------	----------	------------	-----------	--------	-------------

FORD

	& 4B1-62-34, XL		or BJ39ARM (inc. arm)	OEM0936K 29mm OD bush or OEM1006K 33mm OD bush										
1964-66	Falcon XM,XP	BJ34 or BJ34ARM (inc. arm)	BJ39 or BJ39ARM (inc. arm)	idler bush OEM0936K 29mm OD bush	TE184R	TE184R	TE184L	TE184L					TR304 TR304	BJ39ARM - 15¼" long Spring saddle (rubber) - XR3388A (single) Spring saddle (urethane) - OEM335K (pair)
1966-67	Falcon XR Outer tie rod ends longer than inners	BJ34 or BJ34ARM (inc. arm)	BJ74 or BJ74ARM (inc. arm)	SX1117 (rubber) or OEM654K (urethane)	TE414R 250mm long	TE414R 250mm long	TE390L 135mm long	TE390L 135mm long	<p style="text-align: center;">Typical early Ford type Front Suspension</p> <p style="text-align: center;"><i>Illustration intended as a guide only. Use catalogue for correct part number reference.</i></p>				XW3590A manual steer only	BJ74ARM - 18¼" long Camber pin kit - F66 (12.5mm) Spring saddle (rubber) - XR3388A (single) Spring saddle (urethane) - OEM335K (pair) Upper inner control arm kit - SX1118A Shackle Kit (Rear Hanger) - SK6871
1966-67	Falcon XR Outer tie rod ends shorter than inners	BJ34 or BJ34ARM (inc. arm)	BJ74 or BJ74ARM (inc. arm)	SX1117 (rubber) or OEM654K (urethane)	TE391R 120mm long Ball stud 7/16" dia. thread	TE391R 120mm long Ball stud 7/16" dia. thread	TE415L 275mm long Ball stud 7/16" dia. thread	TE415L 275mm long Ball stud 7/16" dia. thread					XW3590A manual steer only	BJ74ARM - 18¼" long Camber pin kit - F66 (12.5mm) Spring saddle (rubber) - XR3388A (single) Spring saddle (urethane) - OEM335K (pair) Upper inner control arm kit - SX1118A Shackle Kit (Rear Hanger) - SK6871
1968-69	Falcon XT,XW	BJ34 or BJ34ARM (inc. arm)	BJ75	SX1117 (rubber) or OEM654K (urethane)	TE391R 120mm long Ball stud 7/16" dia. thread	TE391R 120mm long Ball stud 7/16" dia. thread	TE415L 275mm long Ball stud 7/16" dia. thread	TE415L 275mm long Ball stud 7/16" dia. thread					XW3590A manual steer only	Camber pin kit - F66 (12.5mm) Spring saddle (rubber) - XR3388A (single) Spring saddle (urethane) - OEM335K (pair) Upper inner control arm kit - SX1118A Shackle Kit (Rear Hanger) - SK6871
1969-72	Falcon XW,XY	BJ34 or BJ34ARM (inc. arm)	BJ75	SX1117 (rubber) or OEM654K (urethane)	TE420R Ball stud 1/2" dia. thread	TE420R Ball stud 1/2" dia. thread	TE421L Ball stud 1/2" dia. thread	TE421L Ball stud 1/2" dia. thread					XW3590A manual steer only	Camber pin kit - F66 (12.5mm) Spring saddle (rubber) - XR3388A (single) Spring saddle (urethane) - OEM335K (pair) Upper inner control arm kit - SX1118A Shackle Kit (Rear Hanger) - SK6871
1972-79	Falcon XA,XB,XC - manual steer	BJ94	BJ75 or BJ75ARM (inc. arm)	SX1119 or SX1119U or OEM644K	TE420R Ball stud 1/2" dia. thread	TE420R Ball stud 1/2" dia. thread	TE421L Ball stud 1/2" dia. thread	TE421L Ball stud 1/2" dia. thread	<p>* NOTE - BJ75ARM does not come with bushes. Bushes are available - please specify your requirement when ordering. Up to 5/80 XD use BJ75B12 bush; 6/80-on (XD-on) use BJ75B14 bush.</p>				SX809 (18901)	Camber pin kit - F66 (12.5mm) Spring saddle (rubber) - XR3388A (single) Spring saddle (urethane) - OEM335K (pair) Upper inner control arm kit - SX1118A SX1119 - rubber bushes' both ends SX1119U - rubber/urethane combination OEM644K - urethane bushes' both ends Shackle Kit (Rear Hanger) - SK6871

STEERING and SUSPENSION COMPONENTS



YEAR	MODEL	BALL JOINT UPPER	BALL JOINT LOWER / KING PIN SET	IDLER	TIE ROD END L/H OUTER	TIE ROD END R/H OUTER	TIE ROD END L/H INNER	TIE ROD END R/H INNER	RACK END	SIDE ROD	CENTRE ROD	DRAG LINK	PITMAN	NOTES/OTHER
------	-------	------------------	---------------------------------	-------	-----------------------	-----------------------	-----------------------	-----------------------	----------	----------	------------	-----------	--------	-------------

FALCON

1972-79	Falcon XA,XB,XC - power steer	BJ94	BJ75 or BJ75ARM (inc. arm)	SX1119 or SX1119U or OEM644K	TE420R Ball stud 1/2" dia. thread	TE420R	TE421L Ball stud 1/2" dia. thread	TE421L	** NOTE - BJ75ARM does not come with bushes. Bushes are available - please specify your requirement when ordering. Up to 5/80 XD use BJ75B12 bush; 6/80-on (XD-on) use BJ75B14 bush.				SX809B (18902)	Camber pin kit - F66 (12.5mm) Spring saddle (rubber) - XR3388A (single) Spring saddle (urethane) - OEM335K (pair) Upper inner control arm kit - SX1118A SX1119 - rubber bushes' both ends SX1119U - rubber/urethane combination OEM644K - urethane bushes' both ends Shackle Kit (Rear Hanger) - SK6871
1979-88	Falcon XD,XE,XF - manual steer	BJ94	BJ75 or BJ75ARM (inc. arm)	SX1119 or SX1119U or OEM644K	TE548R	TE548R	TE549L	TE549L			TR3304		SX809 (18901)	BJ75ARM - 18 1/4" long with 2 strut holes ** Camber pin kit - F66 (12.5mm) up to 5/80 Camber pin kit - F67 (14mm) 5/80-on Spring saddle (rubber) - XR3388A (single) Spring saddle (urethane) - OEM335K (pair) Tie rod end sleeve - XD3310A Upper inner control arm kit - SX1146A SX1119 - rubber bushes' both ends SX1119U - rubber/urethane combination OEM644K - urethane bushes' both ends Shackle Kit (Rear Hanger) - SK6871
1979-88	Falcon XD,XE,XF - power steer	BJ94	BJ75 or BJ75ARM (inc. arm)	SX1119 or SX1119U or OEM644K	TE548R	TE548R	TE549L	TE549L			TR3304		SX809B (18902)	BJ75ARM - 18 1/4" long with 2 strut holes ** Camber pin kit - F67 (14mm) Spring saddle (rubber) - XR3388A (single) Spring saddle (urethane) - OEM335K (pair) Tie rod end sleeve - XD3310A Upper inner control arm kit - SX1146A SX1119 - rubber bushes' both ends SX1119U - rubber/urethane combination OEM644K - urethane bushes' both ends Shackle Kit (Rear Hanger) - SK6871
2/88-8/89	Falcon EA	BJ296	BJ292 or BJ292OS (oversize)		TE731 14mm thread	TE731 14mm thread			P191010 (RE817)					14mm Tie rod ends/Rack ends Spring saddle (rubber) - XR3388A (single) Spring saddle (urethane) - OEM335K (pair)
8/89-9/94	Falcon EA,EB,ED	BJ296	BJ292 or BJ292OS (oversize)		TE732 16mm thread	TE732 16mm thread			P191017 (RE818)					16mm Tie rod ends/Rack ends
9/94-9/98	Falcon EF, EL	BJ296	BJ292 or BJ292OS		TE732 16mm thread	TE732 16mm thread			P191041 6mm shorter					16mm Tie rod ends/Rack ends

STEERING and SUSPENSION COMPONENTS



YEAR	MODEL	BALL JOINT UPPER	BALL JOINT LOWER / KING PIN SET	IDLER	TIE ROD END L/H OUTER	TIE ROD END R/H OUTER	TIE ROD END L/H INNER	TIE ROD END R/H INNER	RACK END	SIDE ROD	CENTRE ROD	DRAG LINK	PITMAN	NOTES/OTHER
------	-------	------------------	---------------------------------	-------	-----------------------	-----------------------	-----------------------	-----------------------	----------	----------	------------	-----------	--------	-------------

FORD

			(oversize)											than P191017
9/98-on	Falcon AU - series 1	BJ396	BJ395		TE3289	TE3289			RE651					
3/00-on	Falcon AU - series 2	BJ397	BJ398		TE3289	TE3289			RE651					
FESTIVA														
1990-10/94	Festiva WA		BJ4310 (inc. arm) see note		TE3624R (TE733)	TE3624R (TE733)			RH-RE978 LH-RE979					NOTE - in some applications BJ4310 can be too short. Check length. If too short use BJ4300. (BJ4300 is 10mm longer than BJ4310)
10/94-2/97	Festiva WB		BJ4300 (inc. arm) see note		TE968	TE968			RE9789					
1/97-4/01	Festiva WD													
1/98-4/01	Festiva WF								RE9789					
GALAXIE														
1959-64	Galaxie, Custom	BJ15	BJ16											
1964-66	Galaxie GD ('Y' shaped lower control arm)	BJ15	BJ16		ES351L	ES351L								
1964-66	Galaxie GE (Single 8 par lower control arm)	10262	BJ120											
1965-68	Galaxie, LTD (except Australian origin)	10262	BJ120											
1967-73	Galaxie, LTD, All models	10262	BJ120											
KA														
1997-on	KA		BJ854		TE4417	TE4417			RE4417					
LASER														
2/81-85	Laser KA,KB - manual steer		BJ180 or RH-BJ180ARMRH LH-BJ180ARMLH arm only		TE562L	TE562R			RE842 male end					BJ180 - 12mm ball bolt clip groove BJ330 - 14mm ball bolt clip groove
2/81-85	Laser KA,KB - power steer		BJ180 or RH-BJ180ARMRH		TE562L	TE562R			RE843 male end					BJ180 - 12mm ball bolt clip groove BJ330 - 14mm ball bolt clip groove

STEERING and SUSPENSION COMPONENTS



YEAR	MODEL	BALL JOINT UPPER	BALL JOINT LOWER / KING PIN SET	IDLER	TIE ROD END L/H OUTER	TIE ROD END R/H OUTER	TIE ROD END L/H INNER	TIE ROD END R/H INNER	RACK END	SIDE ROD	CENTRE ROD	DRAG LINK	PITMAN	NOTES/OTHER
------	-------	------------------	---------------------------------	-------	-----------------------	-----------------------	-----------------------	-----------------------	----------	----------	------------	-----------	--------	-------------

FORD

		LH-BJ180ARMLH arm only												
10/85-90	Laser KC,KE - manual steer		BJ330		TE3624R (TE733)	TE3624R (TE733)				CGR-RE891 VGR-RE892				CGR rack has constant gear ratio VGR rack has variable gear ratio
10/85-90	Laser KC,KE - power steer		BJ330		TE3624R (TE733)	TE3624R (TE733)				RH-RE893R LH-RE894L				TE840 has larger taper than TE3624R
3/90-10/94	Laser KF,KH		BJ2006 (16mm spigot) or BJ1572 (18mm spigot)		TE840	TE840				RE1550 (1989-94) m/steer RH-RE1551R LH-RE1551L (1989-94) p/steer RH-RE981 LH-RE980 (1994-on)				TE840 has larger taper than TE3624R Measure ball joint to determine correct size: BJ2006 - dia. of spigot 16mm with 13mm slot BJ1572 - dia. of spigot 18mm with 14mm slot
7/94-6/96	Laser KJ series 1 model 124				TE969	TE969				RH-RE981 LH-RE980				
7/96-6/98	Laser KJ series 1 model 126				TE969	TE969				RH-RE981 LH-RE980				
7/98-2/99	Laser KJ series 1 model 128				TE969	TE969				RH-RE981 LH-RE980				
1994-on	Laser KJ series 2									RE1570				
3/99-on	Laser KN													
	LONGREACH - see FORD COMMERCIAL - UTILITY													
	MAVERICK 4WD - see FORD COMMERCIAL - MAVERICK													
	MAVERICK - USA passenger vehicle													
1970-74	Maverick - U.S.A. passenger vehicle	BJ34	BJ75		TE420R	TE420R								Upper inner control arm kit - SX1118A

STEERING and SUSPENSION COMPONENTS















YEAR	MODEL	BALL JOINT UPPER	BALL JOINT LOWER / KING PIN SET	IDLER	TIE ROD END L/H OUTER	TIE ROD END R/H OUTER	TIE ROD END L/H INNER	TIE ROD END R/H INNER	RACK END	SIDE ROD	CENTRE ROD	DRAG LINK	PITMAN	NOTES/OTHER
------	-------	------------------	---------------------------------	-------	-----------------------	-----------------------	-----------------------	-----------------------	----------	----------	------------	-----------	--------	-------------

		4 bolt mount BJ94 3 bolt mount			Ball stud 1/2" dia. thread										
1975	Maverick - U.S.A. passenger vehicle	BJ34 4 bolt mount BJ94 3 bolt mount												Upper inner control arm kit - SX1118A	
	MARQUIS														
1972-79	Marquis Utility Std 500 - manual steer	BJ94	BJ75	SX1119 or SX1119U or OEM644K	TE420R Ball stud 1/2" dia. thread	TE420R	TE421L Ball stud 1/2" dia. thread	TE421L					SX809 (18901)	Spring saddle (rubber) - XR3388A (single) Spring saddle (urethane) - OEM335K (pair) Upper inner control arm kit - SX1118A SX1119 - rubber bush's both ends SX1119U - rubber/urethane combination OEM644K - urethane bush's both ends	
1972-79	Marquis Utility Std 500 - power steer	BJ94	BJ75	SX1119 or SX1119U or OEM644K	TE420R Ball stud 1/2" dia. thread	TE420R	TE421L Ball stud 1/2" dia. thread	TE421L					SX809B (18902)	Spring saddle (rubber) - XR3388A (single) Spring saddle (urethane) - OEM335K (pair) Upper inner control arm kit - SX1118A SX1119 - rubber bush's both ends SX1119U - rubber/urethane combination OEM644K - urethane bush's both ends	
	METEOR														
2/81-85	Meteor GA,GB - manual steer		BJ180 or RH-BJ180ARMRH LH-BJ180ARMLH		TE562L	TE562R			RE842 male end					BJ180 - 12mm ball bolt clip groove BJ330 - 14mm ball bolt clip groove BJ180ARMLH/RH - arm only	
2/81-85	Meteor GA,GB - power steer		BJ180 or RH-BJ180ARMRH LH-BJ180ARMLH		TE562L	TE562R			RE843 male end					BJ180 - 12mm ball bolt clip groove BJ330 - 14mm ball bolt clip groove BJ180ARMLH/RH - arm only	
10/85-90	Meteor GC - manual steer		BJ330		TE3624R (TE733)	TE3624R (TE733)			CGR-RE891 VGR-RE892					CGR rack has constant gear ratio VGR rack has variable gear ratio	
10/85-90	Meteor GC - power steer		BJ330		TE3624R (TE733)	TE3624R (TE733)			RH-RE893R LH-RE894L						
	MONDEO														
93-6/95	Mondeo HA		RH-BJ1125 inc. arm LH-BJ1126 inc. arm												
7/95-on	Mondeo 2.0L HB, HC		BJ331 or		TE946	TE946			RH-RE954					NOTE: initial replacement of control arms must be fitted as a matched pair (LH & RH) Subsequent replacement can be completed	

STEERING and SUSPENSION COMPONENTS



YEAR	MODEL	BALL JOINT UPPER 	BALL JOINT LOWER / KING PIN SET 	IDLER 	TIE ROD END L/H OUTER 	TIE ROD END R/H OUTER 	TIE ROD END L/H INNER 	TIE ROD END R/H INNER 	RACK END 	SIDE ROD 	CENTRE ROD 	DRAG LINK 	PITMAN 	NOTES/OTHER
------	-------	--	---	--	--	---	---	---	--	--	--	---	---	-------------

		RH-BJ1125 inc. arm LH-BJ1126 inc. arm							LH-RE953					on an individual basis.
MUSTANG														
1964-66	Mustang - 6 cylinder	BJ34 4 bolt mount BJ94 3 bolt mount	BJ39	18704 m/steer	TE163R	TE163R	TE163L	TE163L						
1964-66	Mustang - V8 manual steer	BJ34 4 bolt mount BJ94 3 bolt mount	BJ39	idler bush OEM0936K 29mm OD bush or OEM1006K 33mm OD bush	TE184L	TE184L								
1964-66	Mustang - V8 power steer	BJ34 4 bolt mount BJ94 3 bolt mount	BJ39	idler bush OEM0936K 29mm OD bush or OEM1006K 33mm OD bush	TE184R	TE184L								
1967	Mustang - all models	BJ34 4 bolt mount BJ94 3 bolt mount	10805 Ball joint & control arm	18686 p/steer 18687 m/steer	TE391R 120mm long Ball stud 7/16" dia. thread	TE391R 120mm long	ES364L	ES364L						Upper inner control arm kit - SX1118A
1968-69	Mustang - all models except Boss	BJ34 4 bolt mount BJ94 3 bolt mount	10812 Ball joint & control arm	18686 p/steer 18687 m/steer	TE391R 120mm long Ball stud 7/16" dia. thread	TE391R 120mm long	ES364L	ES364L						Upper inner control arm kit - SX1118A
1969	Mustang Boss	BJ34 4 bolt mount BJ94 3 bolt mount	10812 Ball joint & control arm	18686 p/steer 18687 m/steer	TE420R Ball stud 1/2" dia. thread	TE420R	ES387L	ES387L						Upper inner control arm kit - SX1118A
1970-73	Mustang - all models	BJ34 4 bolt mount BJ94 3 bolt mount	10805 Ball joint & control arm	18686 p/steer 18687 m/steer	TE420R Ball stud 1/2" dia. thread	TE420R	ES387L (1970 only)	ES387L (1970 only)					18801 p/steer	Upper inner control arm kit - SX1118A
1974-78	Mustang - all models		10262	10282										

FOR

STEERING and SUSPENSION COMPONENTS

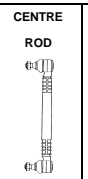
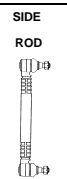
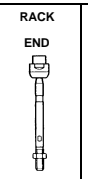
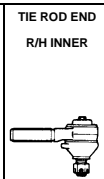
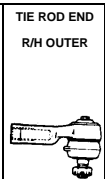
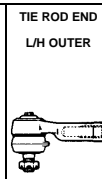
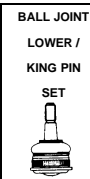

YEAR	MODEL	BALL JOINT UPPER	BALL JOINT LOWER / KING PIN SET	IDLER	TIE ROD END L/H OUTER	TIE ROD END R/H OUTER	TIE ROD END L/H INNER	TIE ROD END R/H INNER	RACK END	SIDE ROD	CENTRE ROD	DRAG LINK	PITMAN	NOTES/OTHER
------	-------	------------------	---------------------------------	-------	-----------------------	-----------------------	-----------------------	-----------------------	----------	----------	------------	-----------	--------	-------------

1979-81	Mustang, Mustang II		10327		ES2128R	ES2128R								
1982-89	Mustang, Mustang II		10327		ES2150R	ES2150R								
1990-93	Mustang, Mustang II		10327		ES3091	ES3091								
1994-98	Mustang, Mustang II		104226		ES3184	ES3184								
PROBE														
6/94-on	Probe ST		RH-BJ4152 LH-BJ4153		TE970	TE970				RH-RE982 LH-RE983				BJ4152/4153 - Control Arm
TAURUS														
3/96-4/99	Taurus		104217		ES3349	ES3349				ES3344				
TELSTAR														
1982-87	Telstar AR,AS - manual steer		BJ306		TE678	TE678				RH-RE844R LH-RE844L				RE844R - overall length 275mm RE844L - overall length 295mm
1982-87	Telstar AR,AS - power steer		BJ306		TE678	TE678				RH-RE895R LH-RE896L				
1987-92	Telstar AT, AV - manual steer		BJ306		TE678	TE678				RE897				
1987-92	Telstar AT, AV - power steer		BJ306		TE678	TE678				RE898				
1992-on	Telstar AX - 2WS		RH-BJ4152 LH-BJ4153		TE970	TE970				RH-RE982 LH-RE983				BJ4152/4153 - Control Arm
1992-on	Telstar AX - 4WS		RH-BJ4152 LH-BJ4153		TE970	TE970				RH-RE984 LH-RE985				BJ4152/4153 - Control Arm
TERRITORY														
2004-on	Territory RWD													
2004-on	Territory AWD													

FOR

STEERING and SUSPENSION COMPONENTS



YEAR	MODEL	BALL JOINT UPPER	BALL JOINT LOWER / KING PIN SET	IDLER	TIE ROD END L/H OUTER	TIE ROD END R/H OUTER	TIE ROD END L/H INNER	TIE ROD END R/H INNER	RACK END	SIDE ROD	CENTRE ROD	DRAG LINK	PITMAN	NOTES/OTHER
------	-------	------------------	---------------------------------	-------	-----------------------	-----------------------	-----------------------	-----------------------	----------	----------	------------	-----------	--------	-------------

THUNDERBIRD														
1958-60	Thunderbird		BJ16											
1967-72	Thunderbird		BJ120											
1980-88	Thunderbird		10327											
ZEPHYR / ZODIAC														
1958-62	Zephyr, Zodiac MkII 206E engine no. 154227-on		BJ28		TE162R	TE161R	TE151L	TE151R						BJ28 - Ball joint repair kit
1962-66	Zephyr Four, Six 2IIE, Zodiac 213E, MkIII				TE172L	TE172R	TE351L	TE350L						

FORD

FORD - Commercial														
1937-41	01C,09C,022C,11C,11C,1GC.... - 0.50ton 01D,02D,09D,1GD,1ND,11D,19D... - 0.75ton 01Y,02Y,09Y,1GY,11Y,19Y... - 1.00ton				310-220	310-221							310-220	
1936-69	Fordson/Thames Trader, FC/NC, 500 series & K150,200,300		KX205											
1961-70	C550,C600,6000lbs. Axle, B600,C600,C700, C7000,F600,F700,F850,F950,N600,N850, N950,N8000,T800,7000lbs. Axle		300-140		310-142	310-143								King pin set 1.234 x 7.440"
1970-73	K500 (K0910), K600 (K1010), K700 (K1110/1111) K750 (K1210/1211) 75--lb axle 5-7.5ton		300-140											King pin set 1.234" x 7.440"

FORD

CARGO														
COURIER														
1965-8/80	Courier 1000kg pickup, truck & utility	BJ99	BJ100	SX1149	TE192L LH thread	TE192L LH thread	TE191R RH thread	TE191R RH thread					TR591	SX1149 - 2 bolt mounting
1979-82	Courier 18, 20, 22 (SGC,SGHW)	BJ99	BJ100	SX1149	TE192L LH thread	TE192L LH thread	TE191R RH thread	TE191R RH thread					TR591	SX1149 - 2 bolt mounting
9/80-85	Courier 20, 22 (SGCD,SGHW)	BJ194	BJ195	SX1150	TE590L	TE590L	TE589R	TE589R					SX5255	SX1150 - 3 bolt mounting

STEERING and SUSPENSION COMPONENTS



YEAR	MODEL	BALL JOINT UPPER	BALL JOINT LOWER / KING PIN SET	IDLER	TIE ROD END L/H OUTER	TIE ROD END R/H OUTER	TIE ROD END L/H INNER	TIE ROD END R/H INNER	RACK END	SIDE ROD	CENTRE ROD	DRAG LINK	PITMAN	NOTES/OTHER
------	-------	------------------	---------------------------------	-------	-----------------------	-----------------------	-----------------------	-----------------------	----------	----------	------------	-----------	--------	-------------

ECONOVAN

1985-87	Courier 20, 22 2WD (SGCH,SGHW)	BJ2003	BJ2004	SX4200	TE590L	TE590L	TE3609R	TE3609R					SX5200	SX5200 - 38 splines & 1 master - top spline diam. 24.7mm
1987-on	Courier 20,22 2WD (SCGE,SGHW)	BJ2003	BJ2004	SX4201	TE590L	TE590L	TE3613R	TE3613R					SX5202	SX5202 - 38 splines & 1 master - top spline diam. 24.7mm
1987-on	Courier 26 4WD (SGHC)	BJ2003	BJ2005	SX4201	TE3667L	TE3667L	TE3613R	TE3613R					SX5202	SX5202 - 38 splines & 1 master - top spline diam. 24.7mm
11/89-on	Courier 4WD (UF66M) B2500, B2600	BJ2003	BJ2005	SX4201	TE3667L	TE3667L	TE3613R	TE3613R					SX1531	SX1531 - 42 splines & 1 master - top spline diam. 26.5mm
	 Courier 4x4	Front Spring Rear Pin	Front Spring Front Shackle L/H	Front Spring Front Shackle R/H	Rear Spring Front Pin PK272	Rear Spring Rear Shackle L/H SK272	Rear Spring Rear Shackle R/H SK272							
	D SERIES													
1975-82	D series - up to 5,500lb f/axle		300-155											King pin set 1.2305" x 7.860"
1967-78	D1000, 9500 & 10640lb axles		KX238		TE419L (ES187L)	TE419R (ES187R)								King pin set 1.433" x 8.500"
1978-81	D1414, 3400, 4830, 7120kg axles - power steer		KX238		TE419L (ES187L)	TE419R (ES187R)						RH-TE419R LH-TE419L		King pin set 1.433" x 8.500"
1971-75	D400(0710/0810) D500(0910.0913) D600(1010/1011/1015) - 7500lb axle 4-6ton		300-140											King pin set 1.234" x 7.440"
1969-75	D750 series D1210/1211/1213 D850 D1211 D850T D1314 - power steer		KX238		TE419L (ES187L)	TE419R (ES187R)						RH-TE419R LH-TE419L (except D850 from '73)		King pin set 1.433" x 8.500"
1969-75	R series bus		KX208		TE419L (ES187L)	TE419R (ES187R)								King pin set 1.376" x 8.21/32"
1971-75	D750 series D1210/1211/1213 D800,D850 D1211, D850T, D1314 - manual steer		KX238		TE419L (ES187L)	TE419R (ES187R)						TE419R RH-front		King pin set 1.433" x 8.500"
	ECONOVAN inc. SPECTRON 2WD													
1977-81	Econovan 1.6 (SGMB) - 750 & 1000kg	BJ198	BJ199	SX1300	TE592L 14mm female threads	TE592L	TE593R 14mm female threads	TE593R					SX5300	
5/81-1/84	Econovan, Spectron 1.6 (SGMB) SA24,SA25,SA32	BJ198	BJ199	SX1300	TE974 12mm female threads	TE974	TE973 12mm female threads	TE973						Please ensure tie rod threads are checked prior to ordering.
5/1983-90	Econovan, Spectron 1.4, 1.8, 2.0,	BJ250	BJ251		TE679	TE679			RE854					model SGM

STEERING and SUSPENSION COMPONENTS



YEAR	MODEL	BALL JOINT UPPER	BALL JOINT LOWER / KING PIN SET	IDLER	TIE ROD END L/H OUTER	TIE ROD END R/H OUTER	TIE ROD END L/H INNER	TIE ROD END R/H INNER	RACK END	SIDE ROD	CENTRE ROD	DRAG LINK	PITMAN	NOTES/OTHER
	2.2 2WD (SGM)								male end					
1986-90	Econovan, Spectron 2.0, 2.2 4WD (SGM)	BJ250	BJ251		TE3615	TE3615			RE854 male end					
SPECTRON 4WD														
1983-84	Spectron 1.6 4WD	BJ198	BJ199		TE679	TE679	TE975	TE975						
5/84-88	Spectron 1.8, 2.0 4WD	BJ250	BJ251 3 bolt holes		TE679	TE679	TE975	TE975						
EXPLORER 4WD														
1995-on	Explorer 4WD		104222						ES3424				RH-TE413L (END)	

L O R D O E E O L O N G

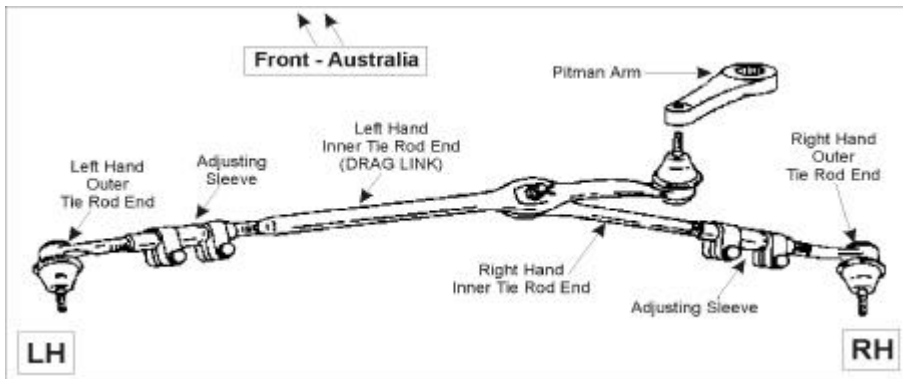

For the correct selection of Inner and Outer Tie Rod Ends to suit American F series vehicles please refer to the illustration left. Where possible the thread size and direction have been included to further assist in correct selection.

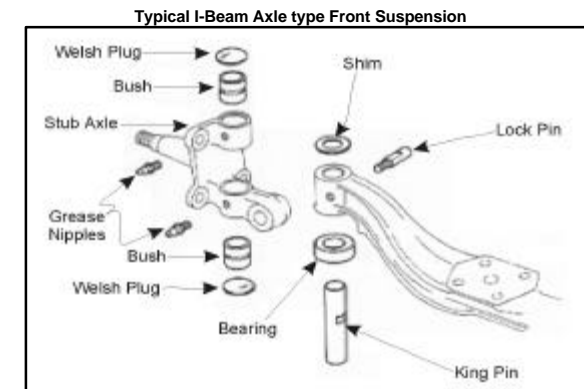

F100/F150 2WD														
1948-52	F100/F150 2WD		K365N		310-220	310-220								King pin set with metal bushes 0.812" x 5.98"
1953-56	F100/F150 2WD		300-122		310-221 RH thread	310-220 LH thread								King pin set with metal bushes 0.859" x 5.86"



YEAR	MODEL	BALL JOINT UPPER	BALL JOINT LOWER / KING PIN SET	IDLER	TIE ROD END L/H OUTER	TIE ROD END R/H OUTER	TIE ROD END L/H INNER	TIE ROD END R/H INNER	RACK END	SIDE ROD	CENTRE ROD	DRAG LINK	PITMAN	NOTES/OTHER
------	-------	------------------	---------------------------------	-------	-----------------------	-----------------------	-----------------------	-----------------------	----------	----------	------------	-----------	--------	-------------

1957-1985

					3.12" stud centre to end									
1957-64	F100/F150 2WD		300-131		310-221 RH thread	310-220 LH thread								King pin set with metal bushes 0.859" x 6.55" - off centre keyway
1965	F100/F150 2WD nylon bush replacement king pin set		300-183					310-179						King pin set with nylon bushes 0.859" x 6.36"
1965	F100/F150 2WD metal bush replacement king pin set		300-185					310-179						King pin set with metal bushes 0.859" x 6.36" - centre keyway
1966-71	F100/F150 2WD nylon bush replacement king pin set		300-184					310-179						King pin set with nylon bushes 0.859" x 6.36"
1966-71	F100/F150 2WD metal bush replacement king pin set		300-202					310-179						King pin set with metal bushes 0.859" x 6.36"
1971-74	F100/F150 2WD nylon bush replacement king pin set		300-184					310-217						King pin set with nylon bushes 0.859" x 6.34"
1971-72	F100/F150 2WD metal bush replacement king pin set		300-202					310-217						King pin set with metal bushes 0.859" x 6.36" - off centre keyway
1973-74	F100/F150 2WD metal bush replacement king pin set		300-199				346-137 (DS794)	310-217				DS181TP adjustable		King pin set with metal bushes 0.859" x 6.36"
1975-79	F100/F150 2WD metal bush replacement king pin set		300-197				346-137 (DS794)	310-217				DS181TP adjustable		King pin set with metal bushes 0.859" x 6.48"
1975-79	F100/F150 2WD nylon bush replacement king pin set		300-237 (also 300-197)				346-137 (DS794)	310-217				DS181TP adjustable		King pin set with nylon bushes 0.859" x 6.48"
1980-8/81	F100/F150 2WD - fitted with king pin front suspension & manual brakes		300-228		310-299 22mm thread RH thread	310-300 20mm thread LH thread	see Drag Link	DS1017 20mm thread	DS1017 -measures roughly 430mm (17") long DS1018P -measures roughly 880mm (35") long			DS1018P (1981-92) single end		King pin set with metal bushes 1.054" x 6.96"
1980-8/81	F100/F150 2WD - fitted with king pin front suspension & power brakes		300-198		310-299 22mm thread RH thread	310-300 20mm thread LH thread	see Drag Link	DS1017 20mm thread	DS1017 -measures roughly 430mm (17") long DS1018P -measures roughly 880mm (35") long			DS1018P (1981-92) single end		King pin set with metal bushes 0.859" x 6.48"
8/81-1985	F100/F150 2WD fitted with ball joint susp	305-150	10253 3/4"-16 threads		310-299 22mm thread RH thread	310-300 20mm thread LH thread	see Drag Link	DS1017 20mm thread	DS1017 -measures roughly 430mm (17") long DS1018P -measures roughly 880mm (35") long			DS1018P (1981-92) single end		Lower ball joint - 3/4" thread

STEERING and SUSPENSION COMPONENTS



YEAR	MODEL	BALL JOINT UPPER	BALL JOINT LOWER / KING PIN SET	IDLER	TIE ROD END L/H OUTER	TIE ROD END R/H OUTER	TIE ROD END L/H INNER	TIE ROD END R/H INNER	RACK END	SIDE ROD	CENTRE ROD	DRAG LINK	PITMAN	NOTES/OTHER
------	-------	------------------	---------------------------------	-------	-----------------------	-----------------------	-----------------------	-----------------------	----------	----------	------------	-----------	--------	-------------

FORD

8/81-1985	F100/F150 2WD fitted with ball joint susp GVW 4700lbs with power brakes	305-150	10380 5/8"-18 threads		310-299 22mm thread RH thread	310-300 20mm thread LH thread	see Drag Link	DS1017 20mm thread		DS1017 - measures roughly 430mm (17") long DS1018P -measures roughly 880mm (35") long		DS1018P (1981-92) single end		Lower ball joint - 5/8" thread
1986	F100/F150 2WD	305-150	10253		310-355 22mm thread RH thread	310-354 20mm thread LH thread	see Drag Link	DS1017 20mm thread		DS1017 - measures roughly 430mm (17") long DS1018P -measures roughly 880mm (35") long		DS1018P (1981-92) single end		
1987-96	F100/F150 2WD	104132	104133		310-355 22mm thread RH thread	310-354 20mm thread LH thread	see Drag Link	DS1017 20mm thread		DS1017 - measures roughly 430mm (17") long DS1018P -measures roughly 880mm (35") long		DS1018P (1981-92) single end		
1997-on	F100/F150 2WD		104222											
	F250 2WD													
1953-56	F250 2WD		300-122		310-221 RH thread	310-220 LH thread								King pin set with metal bushes 0.859" x 5.86"
					3.12" stud centre to end									
1957-64	F250 2WD		300-131		310-221 RH thread	310-220 LH thread								King pin set with metal bushes 0.859" x 6.55"
					3.12" stud centre to end									
1965	F250 2WD nylon bush replacement king pin set		300-183					310-179						King pin set with nylon bushes 0.859" x 6.36"
1965	F250 2WD metal bush replacement king pin set		300-185					310-179						King pin set with metal bushes 0.859" x 6.36"
1966-71	F250 2WD nylon bush replacement king pin set		300-184					310-179						King pin set with nylon bushes 0.859" x 6.36"
1966-71	F250 2WD metal bush replacement king pin set		300-202					310-179						King pin set with metal bushes 0.859" x 6.36"
1971-74	F250 2WD with single piston disc brakes		300-199					310-217				DS181TP adjustable		King pin set with metal bushes 0.859" x 6.36"
1975-79	F250 2WD with single piston disc brakes		300-197					310-217				DS181TP adjustable		King pin set with metal bushes 0.859" x 6.48"
1971-74	F250 2WD - with dual piston disc brakes 6100/6900lb GVW serial# M00,001 to W40,001		300-184					310-218				DS181TP adjustable		King pin set with nylon bushes 0.859" x 6.36"

STEERING and SUSPENSION COMPONENTS



YEAR	MODEL	BALL JOINT UPPER	BALL JOINT LOWER / KING PIN SET	IDLER	TIE ROD END L/H OUTER	TIE ROD END R/H OUTER	TIE ROD END L/H INNER	TIE ROD END R/H INNER	RACK END	SIDE ROD	CENTRE ROD	DRAG LINK	PITMAN	NOTES/OTHER
------	-------	------------------	---------------------------------	-------	-----------------------	-----------------------	-----------------------	-----------------------	----------	----------	------------	-----------	--------	-------------

	nylon bush replacement king pin set													
1971-74	F250 2WD - with dual piston disc brakes 6100/6900lb GVW serial# M00,001 to W40,001 metal bush replacement king pin set		300-202										DS181TP adjustable	King pin set with metal bushes 0.859" x 6.36"
1973-79	F250 2WD - with dual piston disc brakes 6200/9600lb GVW from serial# W40,001 nylon bush replacement king pin set		300-237										DS181TP adjustable	King pin set with nylon bushes 0.859" x 6.48"
1973-79	F250 2WD - with dual piston disc brakes 6200/9600lb GVW from serial# W40,001 metal bush replacement king pin set		300-197										DS181TP adjustable	King pin set with metal bushes 0.859" x 6.48"
1971-79	F250 2WD - with dual piston disc brakes with 6900 & 460 ci, 7500/8100lb GVW metal bush replacement king pin set		300-201										DS181TP adjustable	King pin set with metal bushes 1.054" X 6.45"
1980-85	F250 2WD		300-228		310-299 22mm thread RH thread	310-300 20mm thread LH thread	see Drag Link	DS1017 20mm thread	DS1017 - measures roughly 430mm (17") long DS1018P -measures roughly 880mm (35") long			DS1018P (1981-92) single end	King pin set with metal bushes 1.053" X 6.96"	
1986	F250 2WD		300-228		310-355 22mm thread RH thread	310-354 20mm thread LH thread	see Drag Link	DS1017 20mm thread	DS1017 - measures roughly 430mm (17") long DS1018P -measures roughly 880mm (35") long			DS1018P (1981-92) single end	King pin set with metal bushes 1.054" X 6.96"	
1987-97	F250 2WD - exc Ambulance & Crew Cab - ball joint suspension	104132	104138		310-355 22mm thread RH thread	310-354 20mm thread LH thread	see Drag Link	DS1017 20mm thread	DS1017 - measures roughly 430mm (17") long DS1018P -measures roughly 880mm (35") long			DS1018P (1981-92) single end		
1957-66	F350 2WD F350 2WD		300-129		310-113 RH thread	310-112 LH thread								King pin set .9215" x 7.00"
1967-71	F350 2WD - up to serial# M00,001		300-201										DS041TP adjustable	King pin set with metal bushes 1.054" X 6.45"
1971-79	F350 2WD - from serial# M00,001		300-201										DS041TP adjustable	King pin set with metal bushes 1.054" X 6.45"
1980-85	F350 2WD		300-228		310-299 22mm thread RH thread	310-300 20mm thread LH thread	see Drag Link	DS1017 20mm thread	DS1017 - measures roughly 430mm (17") long DS1018P -measures roughly 880mm (35") long			DS1018P (1981-92) single end	King pin set with metal bushes 1.054" X 6.96"	

STEERING and SUSPENSION COMPONENTS



YEAR	MODEL	BALL JOINT UPPER	BALL JOINT LOWER / KING PIN SET	IDLER	TIE ROD END L/H OUTER	TIE ROD END R/H OUTER	TIE ROD END L/H INNER	TIE ROD END R/H INNER	RACK END	SIDE ROD	CENTRE ROD	DRAG LINK	PITMAN	NOTES/OTHER
------	-------	------------------	---------------------------------	-------	-----------------------	-----------------------	-----------------------	-----------------------	----------	----------	------------	-----------	--------	-------------

1986	F350 2WD exc. Crew Cab		300-228		310-355 22mm thread RH thread	310-354 20mm thread LH thread	see Drag Link	DS1017 20mm thread		DS1017 -measures roughly 430mm (17") long DS1018P -measures roughly 880mm (35") long		DS1018P (1981-92) single end		King pin set with metal bushes 1.054" X 6.96"	
1986	F350 2WD Crew Cab		300-228		310-410 1" thread	310-354 20mm thread LH thread	see Drag Link	DS1017 20mm thread		DS1017 -measures roughly 430mm (17") long DS1018P -measures roughly 880mm (35") long		DS1018P (1981-92) single end		King pin set with metal bushes 1.054" X 6.96"	
1987-96	F350 2WD	104132	104138		310-355 22mm thread RH thread	310-354 20mm thread LH thread	see Drag Link	DS1017 20mm thread		DS1017 -measures roughly 430mm (17") long DS1018P -measures roughly 880mm (35") long		DS1018P (1981-92) single end			
1959-65	F100 & F150 4WD inc. BRONCO F100 4WD with manual steer				310-113 RH thread	310-112 LH thread									
					3.50" stud centre to end										
1966-75	F100 4WD with ball joint suspension with manual steer	305-112	10253												
1973-75	F100 4WD with power steer	305-112	10253			310-236 4.80" thread						DS69TP adjustable		DS69TP - replaces original double ended fixed drag link	
1976-77	F100 4WD	305-112	10253			310-273 5.00" thread						DS69TP adjustable		DS69TP - replaces original double ended fixed drag link	
1978-79	F100 4WD	305-112	10253			310-274 4.75" thread						DS69TP adjustable		DS69TP - replaces original double ended fixed drag link	
1980-5/85	F100, BRONCO 4WD with ball joint suspension	305-126	10253		310-299 22mm thread RH thread	310-300 20mm thread LH thread	see Drag Link	DS1017 20mm thread		DS1017 -measures roughly 430mm (17") long DS1018P -measures roughly 880mm (35") long		DS1018P (1981-92) single end			
5/85-1996	F100,F150,BRONCO 4WD with ball joint suspension	305-126	10253		310-355 22mm thread RH thread	310-354 20mm thread LH thread	see Drag Link	DS1017 20mm thread		DS1017 -measures roughly 430mm (17") long DS1018P -measures roughly 880mm (35") long		DS1018P (1981-92) single end			
1997-on	F150 4WD		104222		ES3366	ES3367	ES3369	ES3370						Adjusting Sleeve - ES3368S	
1959-66	F250 4WD F250 4WD				310-113 RH thread	310-112 LH thread									
					3.50" stud centre to end										

FORD

STEERING and SUSPENSION COMPONENTS

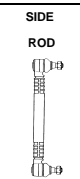
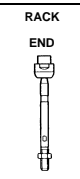
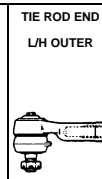
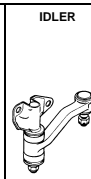
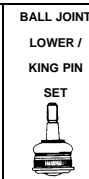

YEAR	MODEL	BALL JOINT UPPER	BALL JOINT LOWER / KING PIN SET	IDLER	TIE ROD END L/H OUTER	TIE ROD END R/H OUTER	TIE ROD END L/H INNER	TIE ROD END R/H INNER	RACK END	SIDE ROD	CENTRE ROD	DRAG LINK	PITMAN	NOTES/OTHER
------	-------	------------------	---------------------------------	-------	-----------------------	-----------------------	-----------------------	-----------------------	----------	----------	------------	-----------	--------	-------------

1967-72	F250 4WD				310-192 RH thread 5.56" stud centre to end	310-191 LH thread								
1973-79	F250 4WD with ball joint suspension	305-112	10253 **									DS69TP adjustable		** some F250 had F350 axles & as such could have 10383 lowers DS69TP - replaces original double ended fixed drag link
1980-96	F250 4WD with ball joint suspension	305-126	10253 **		ES2728L	ES2727R								** some F250 had F350 axles & as such could have 10383 lowers
1998-on	F250 4WD				TE3423	TE3423								
	F350 4WD													
1980-81	F350 4WD	305-126	10253		310-311	310-312								
1981-85	F350 4WD - 3800 & 3850 axle except 4.10 ratio	305-126	10253		310-311	310-312								
1981-85	F350 4WD - 4500, 4600 & 4800 with 4.10 ratio	305-126	10383		310-311	310-312								
1992-97	F350 4WD - 5000 axle	305-126	104149											
1998-on	F250 4WD				TE3423	TE3423								
	F500, F600, F700, F750 TRUCK													
1957-62	F500 & F5600 with 5000lb axle		300-134		310-113 3.5" stud centre to end	310-112								King pin set with metal bushes 1.1285" x 7.67"
1956-69	F500,F600,F700,F750 with 6000lb axle		300-115		310-281 4.44" stud centre to end	310-282								Single keyway king pin with metal bushes 1.234" x 7.480"
1956-69	F500,F600,F700,F750 with 5000lb axle		300-155		310-281 4.44" stud centre to end	310-282								King pin set with metal bushes 1.2305" x 7.86"
1967-79	F500,F600,F700,F750 with 6000 & 7000 (to 1975) lb axle		300-180		310-184 4.43" stud centre to end	310-183								King pin set with metal bushes & 2 oil rings - 1.2305" x 8.89"
1970-73	F500 with 13500,15000,1950lb axle		300-180		310-184 4.43" stud centre to end	310-183								King pin set with metal bushes & 2 oil rings - 1.2305" x 8.89"
1975-90	F600,F700,F750 with 7000, 8000 & 9000lb axle		300-207		310-267 6.07" stud centre to end	310-266								Twin keyway king pin set with metal bushes - 1.433" x 8.25"
1970-73	F600, F700,F750 with 21000,23000 &		300-180		310-184	310-183								King pin set with metal bushes

FOR

STEERING and SUSPENSION COMPONENTS



YEAR	MODEL	BALL JOINT UPPER	BALL JOINT LOWER / KING PIN SET	IDLER	TIE ROD END L/H OUTER	TIE ROD END R/H OUTER	TIE ROD END L/H INNER	TIE ROD END R/H INNER	RACK END	SIDE ROD	CENTRE ROD	DRAG LINK	PITMAN	NOTES/OTHER
------	-------	------------------	---------------------------------	-------	-----------------------	-----------------------	-----------------------	-----------------------	----------	----------	------------	-----------	--------	-------------

D E C O R -

	24500lb axle				4.43" stud centre to end									& 2 oil rings - 1.2305" x 8.89"
	LONGREACH - see UTILITY													
	LOUISVILLE TRUCK													
1970-86	LNT900,LT900,LNT8000,LT8000,LNT9000 with 12000lb axle (check king pin length)		300-182		310-222	310-223								Twin keyway king pin set with metal bushes - 1.7935" x 9.12"
1976-85	L900,LN900,LNT900,LT900,LN8000 LNT8000,LT8000,LT9000 with 9000lb axle with Air Brakes W40001-on		300-215		310-267	310-266								King pin set 1.607" x 9.08"
1975-89	LNT900,LT900,LNT8000,LT8000,LNT9000, LT9000 with 10000,11000 & 12000lb axle (check king pin length)		300-217		310-222	310-223								Twin keyway king pin set with metal bushes - 1.7935" x 10.070"
1980-90	LNT900,LT900,LNT8000,LT8000,LNT9000, LT9000 with 16000, 18000 & 20000 lb axle		300-216		310-222	310-223								Twin keyway king pin set with metal bushes - 1.999" x 11.210"
	MAVERICK													
3/88-10/91	Maverick GY6, KY6				TE984	TE979						DL700	SX5307 p/steer	
10/91-8/93	Maverick GY6, KY6				TE984	TE979						DL700	SX5308	
8/93-3/94	Maverick GY6, KY6				TE984	TE979						DL700	SX5309	
	 Maverick Trayback	Front Spring Rear Pin PK667	Front Spring Front Shackle L/H SK666	Front Spring Front Shackle R/H SK666	Rear Spring Front Pin PK667	Rear Spring Rear Shackle L/H SK666	Rear Spring Rear Shackle R/H SK666							Shackle & Pin Kits

STEERING and SUSPENSION COMPONENTS

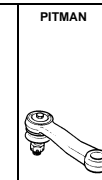
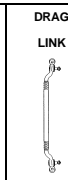
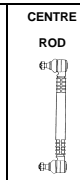
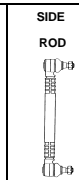
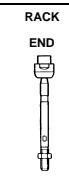
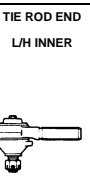
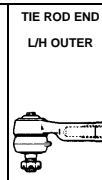
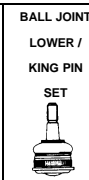

YEAR	MODEL	BALL JOINT UPPER	BALL JOINT LOWER / KING PIN SET	IDLER	TIE ROD END L/H OUTER	TIE ROD END R/H OUTER	TIE ROD END L/H INNER	TIE ROD END R/H INNER	RACK END	SIDE ROD	CENTRE ROD	DRAG LINK	PITMAN	NOTES/OTHER
------	-------	------------------	---------------------------------	-------	-----------------------	-----------------------	-----------------------	-----------------------	----------	----------	------------	-----------	--------	-------------

Ford Commercial

	RAIDER													
1991-96	Raider 26L (4WD)	BJ807	BJ809	BJ1304	TE3667L	TE3667L							SX5303	SX5303 - 24.7-25.7mm tapered spline with 39 splines Some models also have alternate SX1531 27-28mm tapered spline with 43 splines Please check prior to ordering
	SPECTRON - see ECONOVAN													
	TRADER													
1979-on	Trader 0409, 0509, 0711, 0811		KX605		TE606L	TE606R								
1984-89	Trader 3500,1400		KX605		TE606L	TE606R								
1979-98	Trader - check pin size		KX605											King pin set 30mm x 175mm
	TRANSIT													
1965-71	Transit Van 12-35 cwt		KX240 mostly 4cyl		TE412L 20mm thread	TE412R 20mm thread							RH-TE413R (END) LH-TE413L (END) 18mm thread	Grease nipples at side stub axles King pin set 0.812" x 6.110" Oil ring grooves top & bottom
4/72-85	Transit Van 12-35 cwt		KX257		TE412L 20mm thread	TE412R 20mm thread							RH-TE413R (END) LH-TE413L (END) 18mm thread	Grease nipples at top & bottom axles King pin set 0.860" x 5.755"
1985-on	Transit Van		BJ1313											
	UTILITY													
1/88-3/96	Longreach Ute XG 4lt manual steer	BJ94	BJ75	SX1119 or SX1119U or OEM644K	TE548R	TE548R	TE549L	TE549L					SX809 (18901)	SX1119 - rubber bushs' both ends SX1119U - rubber/urethane combination OEM644K - urethane bushs' both ends
1/88-3/96	Longreach Ute XG power steer	BJ94	BJ75	SX1119 or SX1119U or OEM644K	TE548R	TE548R	TE549L	TE549L					SX809B (18902)	SX1119 - rubber bushs' both ends SX1119U - rubber/urethane combination OEM644K - urethane bushs' both ends
3/96-on	Longreach Ute XH	BJ296	BJ292 or BJ292OS (oversize)		TE732 16mm thread	TE732 16mm thread			P191041					16mm Tie rod ends/Rack SB!

STEERING and SUSPENSION COMPONENTS

YEAR	MODEL	BALL JOINT UPPER	BALL JOINT LOWER / KING PIN SET	IDLER	TIE ROD END L/H OUTER	TIE ROD END R/H OUTER	TIE ROD END L/H INNER	TIE ROD END R/H INNER	RACK END	SIDE ROD	CENTRE ROD	DRAG LINK	PITMAN	NOTES/OTHER

FORKLIFT TIE ROD ENDS

UNIVERSAL **SPECIFIC FITMENT**

DIMENSIONS							
Paja#	A	B	C	D	E	F	
FK1	M33 x 1.5 RH	21.10	80	54	01:10	M18 x 1.5	
FK2	M22 x 1.5 LH	21.10	80	54	01:10	M18 x 1.5	
FK3	M24 x 2.0 LH	20.80	75	48	01:10	M16 x 1.5	
FK4	M24 x 2.0 LH	23.40	75	52	01:10	M20 x 1.5	
FK5	M24 x 1.5 LH	20.80	75	48	01:10	M16 x 1.5	

Paja#	Replaces OE#	Suits	F x B
FK541R	45660-20541-71	Toyota	M22 x 18.2 RHT
FK541L	45670-20541-71	Toyota	M22 x 18.2 LHT
FK860R	43750-33860-71	Toyota	M22 x 20.3 RHT
FK860L	43760-33860-71	Toyota	M22 x 20.3 LHT
FK540R	43750-20540-71	Toyota	M20 x 16.4 RHT
FK540L	43760-20540-71	Toyota	M20 x 16.4 LHT
FK547R	43750-20541-71	Toyota	M20 x 18.2 RHT
FK547L	43760-20541-71	Toyota	M20 x 18.2 LHT
FK880R	45660-32880-71	Toyota	M22 x 23.0 RHT
FK880L	45670-32880-71	Toyota	M22 x 23.0 LHT
FK750R	43750-23750-71	Toyota	
FK750L	43760-23750-71	Toyota	

FK520R	48520-L6001	Nissan	M22 x 18.0 RHT
FK520L	48521-L6001	Nissan	M22 x 18.0 LHT
FK521R	48520-L1100	Nissan	M20 x 18.0 RHT
FK521L	48521-L1100	Nissan	M20 x 18.0 LHT
FK852R	48520-00H04	Nissan	
FK852L	48520-10H04	Nissan	

FK242R	3EB-24-11200	Komatsu	M20 x 20.0 RHT
FK242L	34B-24-11700	Komatsu	M20 x 20.0 LHT
FK246R	3EC-24-11600	Komatsu	M22 x 20.0 RHT
FK246L	3EC-24-11500	Komatsu	M22 x 20.0 LHT
FK413R	304-41-31921	Komatsu	M16 x 18.0 RHT
FK827R	358-27-11602	Komatsu	M16 x 18.0 LHT
FK243R	3EB-24-21310	Komatsu	M22 x 18.2 RHT
FK243L	3EB-24-21410	Komatsu	M22 x 18.2 LHT
FK271R	34C-27-11800	Komatsu	M24 x 24.0 RHT
FK271L	34C-27-11900	Komatsu	M24 x 24.0 LHT

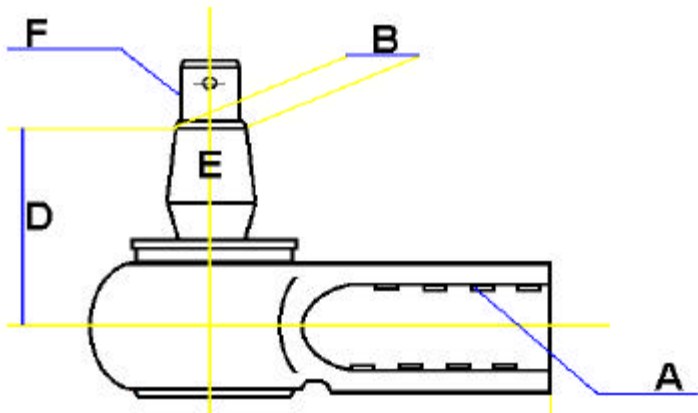

STEERING and SUSPENSION COMPONENTS



YEAR	MODEL	BALL JOINT UPPER	BALL JOINT LOWER / KING PIN SET	IDLER	TIE ROD END L/H OUTER	TIE ROD END R/H OUTER	TIE ROD END L/H INNER	TIE ROD END R/H INNER	RACK END	SIDE ROD	CENTRE ROD	DRAG LINK	PITMAN	NOTES/OTHER
------	-------	------------------	---------------------------------	-------	-----------------------	-----------------------	-----------------------	-----------------------	----------	----------	------------	-----------	--------	-------------

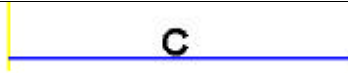

FK912R	91243-15300	Mitsubishi	M20 x 18.5 RHT
FK912L	91243-15700	Mitsubishi	M20 x 18.5 LHT
FK913R	91243-11100	Mitsubishi	M20 x 16.4 RHT
FK913L	91243-11200	Mitsubishi	M20 x 16.4 LHT
FK918R	91843-21100	Mitsubishi	M22 x 22.2 RHT
FK918L	91843-31200	Mitsubishi	M22 x 22.2 LHT
FK915R	91255-10800	Mitsubishi	M18 x 14.5 RHT

FK257R	25784-30412	TCM	M24 x 25.0 RHT
FK257L	25784-30432	TCM	M24 x 25.0 LHT

FUSO - see MITSUBISHI

GMH

**G
M
H**

YEAR	MODEL	BALL JOINT UPPER	BALL JOINT LOWER / KING PIN SET	IDLER	TIE ROD END L/H OUTER	TIE ROD END R/H OUTER	TIE ROD END L/H INNER	TIE ROD END R/H INNER	RACK END	SIDE ROD	CENTRE ROD	DRAG LINK	PITMAN	NOTES/OTHER
APOLLO														
1973-74	Apollo (U.S.A.)	BJ54	BJ55 or BJ55OS (oversize)											
8/89-4/93	Apollo JK, JL - 2.0 4 cyl - Japanese Steering Rack		BJ231		TE648	TE648			RE880					RE880 - 14mm dia. shaft & 14mm thread @ rack end shaft
8/89-4/93	Apollo JK, JL - 2.0 4 cyl - TRW Steering Rack		BJ231		TE648	TE648								RH-P191008 - 14mm dia. shaft & 16mm thread @ rack shaft & LH-P191009 - has recess for steering damper bracket P191008 - 14mm dia. shaft & 16mm thread @ rack end shaft
4/93-8/97	Apollo JM, JP - 2.2 4 cyl & 3.0 V6		BJ301		TE751	TE751			P191020 (RE992)					
ASTRA														
8/84-4/86	Astra LB, LC (TRW rack)		BJ242		TE664	TE664			P191001					
8/84-4/86	Astra LB, LC (imported rack)		BJ242		TE664	TE664			RE857 male end					RE857 - 12mm tie rod end thread
1986-on	Astra LD - manual steer (TRW rack)		BJ261		TE739 14mm thread	TE739 14mm thread			P191011 (RE905)					TRW steering rack P191011 - 14mm tie rod end thread TE739 - 14mm x 78mm
1986-4/88	Astra LD - power steer (imported rack)		BJ261		TE713 12mm thread	TE713 12mm thread			RE857 male end					imported steering rack RE857 - 12mm tie rod end thread TE713 - 12mm x 101mm

STEERING and SUSPENSION COMPONENTS



YEAR	MODEL	BALL JOINT UPPER	BALL JOINT LOWER / KING PIN SET	IDLER	TIE ROD END L/H OUTER	TIE ROD END R/H OUTER	TIE ROD END L/H INNER	TIE ROD END R/H INNER	RACK END	SIDE ROD	CENTRE ROD	DRAG LINK	PITMAN	NOTES/OTHER
4/88-89	Astra LD - power steer (TRW rack)		BJ261		TE739 14mm thread	TE739 14mm thread			P191011 (RE905)					TRW steering rack P191011 - 14mm tie rod end thread TE739 - 14mm x 78mm
	BARINA													
2/85-1/89	MB, ML, MF		BJ400 control arm		TE3628R	TE3628R			RE990 ** female					** check dimensions. This rack end suits only: 14x1.5 female R/E thread & 12x1.25 TRE thread 285mm overall length (end to end)
1991-on	MH - up to Chassis# JSAEAB35S00140001		RH-BJ4158 LH-BJ4159		TE988	TE988			RE990 female					BJ4158/BJ4159 - inc. arm
1994-on	SB		BJ841		TE941	TE941			RE950 male					
	CALIBRA													
1992-on	Calibra YE		BJ185		TE940	TE940								
	CAMIRA													
8/82-89	Camira JB, JD, JE		BJ185		TE555L	TE555R								both tie rod ends - left hand thread
	COMMODORE													
1978-7/84	Commodore VB, VC, VH, VK - manual steer Gears Stamped 9945911 & 92014737		BJ166 or BJ166OS (oversize)		TE525R	TE525R			RE821 female end					Adjustable panhard rod - OEMAPR Z' Bar - SX2948 - adds 2° positive caster SX2948 - 2 required per vehicle - will work with original bushes
1978-7/84	Commodore VB, VC, VH, VK - power steer		BJ166 or BJ166OS (oversize)		TE526R	TE526R			RE819 female end					Adjustable panhard rod - OEMAPR Z' Bar - SX2948 - adds 2° positive caster SX2948 - 2 required per vehicle - will work with original bushes
7/84-86	Commodore VK - manual steer Gears Stamped 92025869		BJ166 or BJ166OS (oversize)		TE525R	TE525R			RE822 male end					Adjustable panhard rod - OEMAPR Z' Bar - SX2948 - adds 2° positive caster SX2948 - 2 required per vehicle - will work with original bushes
7/84-86	Commodore VH, VK - power steer		BJ166 or BJ166OS (oversize)		TE526R	TE526R			P191003 (RE820) male end					Adjustable panhard rod - OEMAPR Z' Bar - SX2948 - adds 2° positive caster SX2948 - 2 required per vehicle - will work with original bushes
2/86-10/91	Commodore VL, VN - manual steer		BJ166 or BJ166OS (oversize)		TE738	TE738			P191012 (RE823/824)					Adjustable panhard rod - OEMAPR Z' Bar - SX2948 - adds 2° positive caster SX2948 - 2 required per vehicle - will work with original bushes
2/86-7/93	Commodore VL, VN, VP - power steer		BJ166 or BJ166OS		TE738	TE738			P191012 (RE823/824)					Adjustable panhard rod - OEMAPR Z' Bar - SX2948 - adds 2° positive caster

O.E.M. - COE00000

STEERING and SUSPENSION COMPONENTS



YEAR	MODEL	BALL JOINT UPPER	BALL JOINT LOWER / KING PIN SET	IDLER	TIE ROD END L/H OUTER	TIE ROD END R/H OUTER	TIE ROD END L/H INNER	TIE ROD END R/H INNER	RACK END	SIDE ROD	CENTRE ROD	DRAG LINK	PITMAN	NOTES/OTHER
------	-------	------------------	---------------------------------	-------	-----------------------	-----------------------	-----------------------	-----------------------	----------	----------	------------	-----------	--------	-------------

			(oversize)											SX2948 - 2 required per vehicle - will work with original bushes
7/93-9/97	Commodore VR, VS		RH-BJ300R LH-BJ300L		TE750 16mm thread	TE750 16mm thread			P191031 (RE951)					Adjustable panhard rod - OEMAPR Z' Bar - SX2948 - adds 2° positive caster SX2948 - 2 required per vehicle - will work with original bushes
9/97-8/99	Commodore VT - to VIN# L492504		BJ8035 spigot		TE750 16mm thread	TE750 16mm thread			RE1042					BJ8035 - ball joint with spigot
8/99-01	Commodore VT - from VIN# L492505		BJ8036 thread		TE3049	TE3049			RE3047					BJ8036 - ball joint with thread
2001-03	Commodore VX		BJ8036		TE3049	TE3049								
2003-00	Commodore VY													
	GEMINI													
1974-79	Gemini TX, TC, TD	BJ117	BJ118		TE491R	TE491R			RE873					
1979-85	Gemini TE, TF, TG	BJ117	BJ118		TE491R	TE491R			RE845 female end					
3/85-88	Gemini RB JT150/600 - manual steer		BJ262		TE716R	TE716R			RE874					
3/85-88	Gemini RB JT150/600 - power steer		BJ262		TE716R	TE716R			RE875					
	HOLDEN													
1938-52	Series 40,50 (to early 1942) 60,70,90				TE175L	TE175L								

MG

STEERING and SUSPENSION COMPONENTS



YEAR	MODEL	BALL JOINT UPPER	BALL JOINT LOWER / KING PIN SET	IDLER	TIE ROD END L/H OUTER	TIE ROD END R/H OUTER	TIE ROD END L/H INNER	TIE ROD END R/H INNER	RACK END	SIDE ROD	CENTRE ROD	DRAG LINK	PITMAN	NOTES/OTHER
------	-------	---------------------	--	-------	--------------------------	--------------------------	--------------------------	--------------------------	-------------	-------------	---------------	--------------	--------	-------------

HOLDEN

1942-52	Series 40,50				TE52L	TE52L								Shackle Kit (Rear Hanger) - SK4856 to suit FJ wide springs Shackle Kit (Rear Hanger) - SK4852 to suit 1948-52 narrow springs
1948-56	Holden 48, 50, FJ,	SX17 upper outer pivot pin	KX17 king pin set or c/over king pins inc. stub axle	SX1039 <i>idler support</i> SX1095 <i>idler set</i>	TE189R	TE189R								Lower outer pivot pin - SX18 <i>idler support - connects idler arm to chassis</i> <i>idler set - connects support to centre rod</i> Shackle Kit (Rear Hanger) - SK4856 to suit FJ wide springs Shackle Kit (Rear Hanger) - SK4852 to suit 1948-52 narrow springs Upper Inner Repair Kit - SX1015RK Lower Inner Repair Kit - SX1026RK

Typical of Early GM type Front Suspension

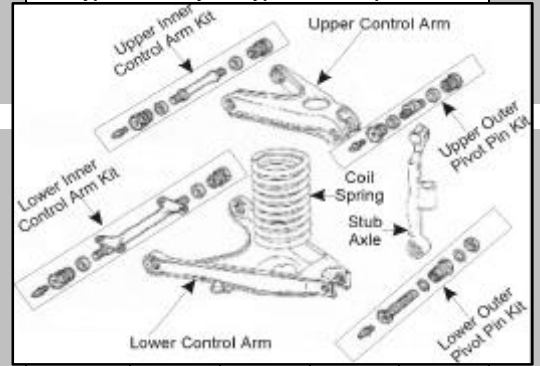

GM HOLDEN

1956-59	Holden FE, FC	SX17 upper outer pivot pin	KX17 king pin set or c/over king pins inc. stub axle	SX1039 <i>idler support</i> SX1095 <i>idler set</i>	TE189R	TE189R								Upper inner control arm kit - SX1037A Lower inner control arm kit - SX1038A Bush to suit SX1037A - 7408965 Bush to suit SX1038A - 7408958 Shackle Kit (Rear Hanger) - SK5659 <i>idler support - connects idler arm to chassis</i> <i>idler set - connects support to centre rod</i>
1960-65	Holden FB, EK, EJ, EH all models	SX71 upper outer pivot pin	KX194 king pin set or c/over king pins inc. stub axle	SX1039 <i>idler support</i> SX1095 <i>idler set</i>	TE189R	TE189R								Upper inner control arm kit - SX1037A Lower inner control arm kit - SX1038A Bush to suit SX1037A - 7408965 Bush to suit SX1038A - 7408958 Shackle Kit (Rear Hanger) - SK6065 <i>idler support - connects idler arm to chassis</i> <i>idler set - connects support to centre rod</i>
1964-65	Holden HD with king pin suspension EH panel van & utility with 2.25" brake	SX71 upper outer	KX194 king pin set	SX1039 <i>idler support</i>	TE189R	TE189R								Upper inner control arm kit - SX1089A Lower inner control arm kit - SX1090A

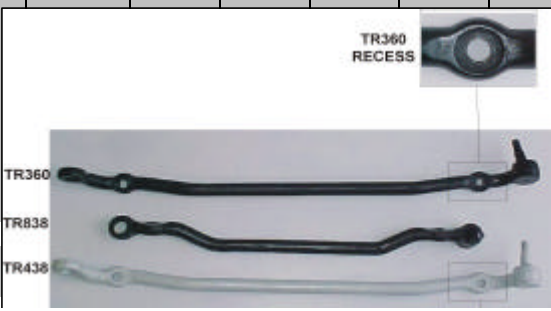

STEERING and SUSPENSION COMPONENTS



YEAR	MODEL	BALL JOINT UPPER	BALL JOINT LOWER / KING PIN SET	IDLER	TIE ROD END L/H OUTER	TIE ROD END R/H OUTER	TIE ROD END L/H INNER	TIE ROD END R/H INNER	RACK END	SIDE ROD	CENTRE ROD	DRAG LINK	PITMAN	NOTES/OTHER
------	-------	------------------	---------------------------------	-------	-----------------------	-----------------------	-----------------------	-----------------------	----------	----------	------------	-----------	--------	-------------

		pivot pin SX18 lower outer pivot pin	or c/over king pins inc. stub axle RH - KXEHR LH - KXEHL	SX1095 <i>idler set</i>										 Bush to suit SX1089A - 7427788 Bush to suit SX1090A - 7428002 Shackle Kit (Rear Hanger) - SK6065 <i>idler support - connects idler arm to chassis</i> <i>idler set - connects support to centre rod</i>
1965-67	Holden HD,HR with ball joint suspension	BJ54	BJ55 or BJ55OS (oversize)	SX1039 <i>idler support</i> SX1095 <i>idler set</i>	TE189R	TE189R	TE358L	TE358L			TR838 exchange			Upper inner control arm kit - SX1094A Lower inner control arm kit - SX1090A Bush to suit SX1094A - 7427788 Bush to suit SX1090A - 7428002 Shackle Kit (Rear Hanger) - SK6065 <i>idler support - connects idler arm to chassis</i> <i>idler set - connects support to centre rod</i>
1968-71	Holden HK, HT & Early HG 11/16" Male thread tie rod ends	BJ54	BJ55 or BJ55OS (oversize)	SX1113 <i>idler support</i> SX1112 <i>idler set</i> NLA	TE190L	TE189R	TE189R	TE190L			TR438 exchange			Upper inner control arm kit - SX1111A Lower inner control arm kit - SX1114A Bush to suit SX1111A - 7427788 Bush to suit SX1114A - 7434230 Shackle Kit (Rear Hanger) - SK6871 <i>idler support - connects idler arm to chassis</i> <i>idler set - connects support to centre rod</i>
1969-71	Holden Late HG 9/16" Female thread tie rod ends	BJ54	BJ55 or BJ55OS (oversize)	SX1113 <i>idler support</i> SX1112 <i>idler set</i> NLA	TE195R	TE195L	TE195L	TE195R			TR360 exchange			Shackle Kit (Rear Hanger) - SK6871 <i>idler support - connects idler arm to chassis</i> TE195R&LG - have side grease nipples for greasing after fitment on inner locations <i>idler set - connects support to centre rod</i> <i>idler set - connects support to centre rod</i>

Metal Bush Dimensions

If the Control Arm replacement kit you require is no longer manufactured, these metal bushes are available.

Kit	Bush #	per vehicle
SX1037A	7408965	4
SX1038A	7408958	4
SX1089A	7427788	4
SX1090	7428002	4
SX1094A	7427788	4
SX1111A	7427788	4
SX1114A	7434230	4

Please ensure you follow manufacturers guidelines when replacing automotive components.

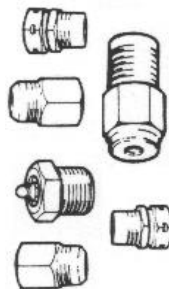

TR559 & TR559B

Correct Selection of Holden Drag Link

TR559B has an altered angle and position of one ball pin when compared to TR559. This is to allow for radial tuned suspension. To check which is required, position a straight edge along the centre rod line: if the straight edge is parallel to the centre rod, it is a TR559; if the straight edge shows an angle, it is a TR559B. Check also for a casting 'B' on the TR559B for further identification



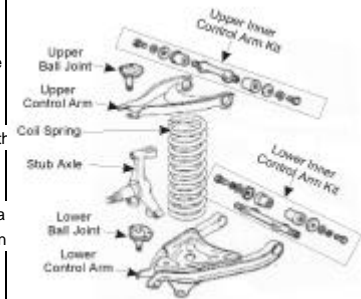







Typical Holden Coil Spring Suspension



1971-80	Holden HQ, HJ, HX sedan, van, utility &	BJ54	BJ55 or	SX1132	TE195R	TE195L	TE195L	TE195R			TR559	see Centre Link	SX709	Female thread tie rod ends
---------	---	------	---------	--------	--------	--------	--------	--------	--	--	-------	-----------------	-------	----------------------------

STEERING and SUSPENSION COMPONENTS

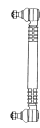

YEAR	MODEL	BALL JOINT UPPER 	BALL JOINT LOWER / KING PIN SET 	IDLER 	TIE ROD END L/H OUTER 	TIE ROD END R/H OUTER 	TIE ROD END L/H INNER 	TIE ROD END R/H INNER 	RACK END 	SIDE ROD 	CENTRE ROD 	DRAG LINK 	PITMAN 	NOTES/OTHER
------	-------	--	---	--	--	---	---	---	--	--	--	---	---	-------------

	1ton cab/chassis - manual steer		BJ55OS (oversize)	SX1132ARM - arm that SX1132 fits into									HQ/HJ Only		TE195RG&LG - have side grease nipples for greasing after fitment on inner locations Shackle Kit (Rear Hanger) - SK7181 to suit HQ-WB Ute/Van/1 Ton
1971-80	Holden HQ, HJ, HX sedan, van, utility & 1ton cab/chassis - power steer	BJ54	BJ55 or BJ55OS (oversize)	SX1132 SX1132ARM - arm that SX1132 fits into	TE195R	TE195L	TE195L	TE195R					TR559 HQ/HJ Only see Centre Link	SX709B	Female thread tie rod ends TE195RG&LG - have side grease nipples for greasing after fitment on inner locations Shackle Kit (Rear Hanger) - SK7181 to suit Ute/Van/1 Ton
1977-81	Holden HZ, WB - with radial tuned suspension - manual steer	BJ54	BJ55 or BJ55OS (oversize)	SX1132 SX1132ARM - arm that SX1132 fits into	TE195R	TE195L	TE195L	TE195R					TR559B see Centre Link	SX709	Female thread tie rod ends TE195RG&LG - have side grease nipples for greasing after fitment on inner locations Shackle Kit (Rear Hanger) - SK7181 to suit Ute/Van/1 Ton
1977-81	Holden HZ, WB - with radial tuned suspension - power steer	BJ54	BJ55 or BJ55OS (oversize)	SX1132 SX1132ARM - arm that SX1132 fits into	TE195R	TE195L	TE195L	TE195R					TR559B see Centre Link	SX709B	Female thread tie rod ends TE195RG&LG - have side grease nipples for greasing after fitment on inner locations Shackle Kit (Rear Hanger) - SK7181 to suit Ute/Van/1 Ton
	NOVA														
1989-94	Nova LE,LF - manual steer		RH-BJ270 LH-BJ271		TE648	TE648			P191008						P191008 - 14mm dia. shaft & 16mm thread @ rack shaft end
1989-94	Nova LE,LF - power steer		RH-BJ270 LH-BJ271		TE648	TE648			RE867						
1994-on	Nova LG		BJ827		TE996	TE996			RE991						
	PIAZZA														
6/81-90	Piazza YB								RE845						
	PONTIAC - see PONTIAC														
	STATESMAN														
1971-78	Statesman HQ, HJ, HX - manual steer	BJ54	BJ55 or BJ55OS (oversize)	SX1132 SX1132ARM - arm that SX1132 fits into	TE195R	TE195L	TE195L	TE195R					TR559 see Centre Link	SX709	Female thread tie rod ends
1971-78	Statesman HQ, HJ, HX - power steer	BJ54	BJ55 or BJ55OS	SX1132	TE195R	TE195L	TE195L	TE195R					TR559 see Centre Link	SX709B	Female thread tie rod ends

**G
M
H**

STEERING and SUSPENSION COMPONENTS



YEAR	MODEL	BALL JOINT UPPER	BALL JOINT LOWER / KING PIN SET	IDLER	TIE ROD END L/H OUTER	TIE ROD END R/H OUTER	TIE ROD END L/H INNER	TIE ROD END R/H INNER	RACK END	SIDE ROD	CENTRE ROD	DRAG LINK	PITMAN	NOTES/OTHER
------	-------	------------------	---------------------------------	-------	-----------------------	-----------------------	-----------------------	-----------------------	----------	----------	------------	-----------	--------	-------------

			(oversize)	SX1132ARM - arm that SX1132 fits into											
1978-85	Statesman HZ, WB - manual steer	BJ54	BJ55 or BJ55OS (oversize)	SX1132	TE195R	TE195L	TE195L	TE195R			TR559B	see Centre Link	SX709		
				SX1132ARM - arm that SX1132 fits into											
1978-85	Statesman HZ, WB - power steer	BJ54	BJ55 or BJ55OS (oversize)	SX1132	TE195R	TE195L	TE195L	TE195R			TR559B	see Centre Link	SX709B		
				SX1132ARM - arm that SX1132 fits into											
1990-3/94	Statesman VQ		BJ166 or BJ166OS (oversize)		TE526R	TE526R			P191012 (RE824)						
3/94-6/99	Statesman VR, VS		RH-BJ300R LH-BJ300L		TE750	TE750			P191031 (RE951)						
6/99-on	Statesman WH - to VIN# L492688		BJ8035 spigot		TE750 16x1.5mm	TE750 16x1.5mm			RE1042 16x1.5mm					NOTE: VIN change	
6/99-on	Statesman WH - from VIN# L492688		BJ8036 thread		TE3049 16x2.0mm	TE3049 16x2.0mm			RE3047 16x2.0mm					NOTE: VIN change	
	TORANA (Includes Sunbird)														
1967-73	Torana HB, LC, LJ, TA - 4cyl	BJ42	BJ57		TE179R	TE179R									
1973-75	Torana TA - 4cyl	BJ54	BJ55 or BJ55OS (oversize)		TE195R	TE195R								TE195RG - have side grease nipples to eliminate fouling in some applications	
1969-73	Torana LC,LJ - 6cyl	BJ54	BJ55 or BJ55OS (oversize)		TE195R	TE195R			RE826					TE195RG - have side grease nipples to eliminate fouling in some applications	
3/74-80	Torana, Sunbird LH, LX, UC - 4/6/8cyl	BJ54	BJ55 or BJ55OS (oversize)		TE195R	TE195R			P104023 LX & UC only					P104023 - suits LX and UC only TE195RG - have side grease nipples to eliminate fouling in some applications	
	VECTRA														
1997-on	Vectra Sedan and Hatchback		BJ185		TE940	TE940			RE6418						

STEERING and SUSPENSION COMPONENTS



YEAR	MODEL	BALL JOINT UPPER	BALL JOINT LOWER / KING PIN SET	IDLER	TIE ROD END L/H OUTER	TIE ROD END R/H OUTER	TIE ROD END L/H INNER	TIE ROD END R/H INNER	RACK END	SIDE ROD	CENTRE ROD	DRAG LINK	PITMAN	NOTES/OTHER
------	-------	------------------	---------------------------------	-------	-----------------------	-----------------------	-----------------------	-----------------------	----------	----------	------------	-----------	--------	-------------

GMH - Commercial

GMH - Commercial														
BARINA COMBO VAN														
1/94-on	Combo Van		BJ841		TE941	TE941			RE950					
DROVER														
1985-87	Drover QB 4WD				TE692L	TE692R	TE693	TE693					DL307	
	Drover	Front Spring Rear Pin PK657	Front Spring Front Shackle L/H SK656	Front Spring Front Shackle R/H SK656	Rear Spring Front Pin PK657	Rear Spring Rear Shackle L/H SK656	Rear Spring Rear Shackle R/H SK656							Shackle & Pin Kits
ISUZU - see ISUZU														
JACKAROO														
11/81-10/86	Jackaroo UBS13,16,52 4WD & 2WD wagon	BJ203	BJ202	SX3251 idler pivot 	TE596R Female RHT BLD-14mm BHD-16mm	TE596R			RE847			TR625		BJ202 - 70mm centre to centre between mounting holes closest to ball stud & 30mm centre to centre between mounting holes furthest from ball stud
11/86-11/91	Jackaroo UBS17,55 4WD & 2WD wagon	BJ203	BJ282	SX3251 idler pivot 	TE5281L Female LHT BLD-16mm	TE5281R Female RHT BHD-18mm	TE5281R Female RHT BLD-16mm	TE5281L Female LHT BHD-18mm						BJ282 - 62mm centre to centre between mounting holes closest to ball stud & 80mm centre to centre between mounting holes furthest from ball stud
12/91-on	Jackaroo UBS25,69 4WD	BJ804	BJ282	SX3852	TE5281L Female LHT BLD-16mm	TE5281R Female RHT BHD-18mm	TE5281R Female RHT BLD-16mm	TE5281L Female LHT BHD-18mm				TR950		
	Jackaroo IFS/Leaf Spring	Front Spring Rear Pin PK269	Front Spring Front Shackle L/H SK269	Front Spring Front Shackle R/H SK269	Rear Spring Front Pin PK269	Rear Spring Rear Shackle L/H SK269	Rear Spring Rear Shackle R/H SK269							
LUV														
1972-81	Luv 2WD KB20,25	BJ201	BJ202		TE595L	TE595R							TR668	<i>please specify if lock nut is required</i>

BJ281



4 mounting holes - Closest to ball stud = no thread. Furthest from ball stud = threaded. 52mm between mounting holes. Non thread holes point upwards.

BJ282 (BJ806)



4 mounting holes - no thread 62mm between mounting holes closest to ball stud 80mm between mounting holes furthest from ball stud

BJ202



BJ204



STEERING and SUSPENSION COMPONENTS

GMH - Commercial



YEAR	MODEL	BALL JOINT UPPER	BALL JOINT LOWER / KING PIN SET	IDLER	TIE ROD END L/H OUTER	TIE ROD END R/H OUTER	TIE ROD END L/H INNER	TIE ROD END R/H INNER	RACK END	SIDE ROD	CENTRE ROD	DRAG LINK	PITMAN	NOTES/OTHER
------	-------	------------------	---------------------------------	-------	-----------------------	-----------------------	-----------------------	-----------------------	----------	----------	------------	-----------	--------	-------------

	RODEO (2WD)													 4 mounting holes - no thread 70mm between mounting holes closest to ball stud 30mm between mounting holes furthest from ball stud
1972-81	Rodeo KB20,25 2WD	BJ201	BJ202		TE595L	TE595R								 4 mounting holes - Closest to ball stud = no thread. Furthest from ball stud = threaded. 42mm between mounting holes. Non thread holes point downwards
6/81-88	Rodeo KB & KBD26,27,28 2WD 1000kg	BJ203	BJ204 no thread	SX3251 idler pivot	TE596R Female RHT BLD-14mm BHD-16mm	TE596R			RE846		TR625			BJ204 - 42mm centre to centre between mounting holes. Holes closest to ball stud = no thread. Furthest from ball stud = threaded.
5/88-on	Rodeo TFR17,54 2WD	BJ805	BJ281 threaded	SX3251 idler pivot	TE5281L Female LHT BLD-16mm	TE5281R Female RHT BHD-18mm	TE5281R Female RHT BLD-16mm	TE5281L Female LHT BHD-18mm			TR626			BJ281 - 52mm centre to centre between mounting holes. Holes closest to ball stud = no thread. Furthest from ball stud = threaded.
	RODEO (4WD)													
5/79-81	Rodeo KB40,KB41 4WD wagon	BJ201	BJ202	SX3251 idler pivot	TE596R Female RHT BLD-14mm BHD-16mm	TE596R			RE847					BJ201 - please specify if lock nut is required
6/81-4/87	Rodeo KB4 & KBD4 series 4WD wagon	BJ203	BJ202	SX3251 idler pivot	TE596R Female RHT BLD-14mm BHD-16mm	TE596R			RE847		TR625			
5/87-5/89	Rodeo TFS17,54 4WD	BJ203	BJ202	SX3251 idler pivot	TE596R Female RHT BLD-14mm BHD-16mm	TE596R			RE847		TR625			
				or SX9710 idler arm										
5/89-on	Rodeo TFR16,17 & TFS55 4WD	BJ805	BJ282	SX3251 idler pivot	TE5281L Female LHT BLD-16mm	TE5281R Female RHT BHD-18mm	TE5281R Female RHT BLD-16mm	TE5281L Female LHT BHD-18mm	RE976		TR890			
														 TR890

STEERING and SUSPENSION COMPONENTS



YEAR	MODEL	BALL JOINT UPPER	BALL JOINT LOWER / KING PIN SET	IDLER	TIE ROD END L/H OUTER	TIE ROD END R/H OUTER	TIE ROD END L/H INNER	TIE ROD END R/H INNER	RACK END	SIDE ROD	CENTRE ROD	DRAG LINK	PITMAN	NOTES/OTHER
------	-------	------------------	---------------------------------	-------	-----------------------	-----------------------	-----------------------	-----------------------	----------	----------	------------	-----------	--------	-------------



				or SX9710 idler arm										
--	--	--	--	---------------------	--	--	--	--	--	--	--	--	--	--

	Rodeo 1983-on	Front Spring Rear Pin	Front Spring Front Shackle L/H	Front Spring Front Shackle R/H	Rear Spring Front Pin PK269	Rear Spring Rear Shackle L/H SK269	Rear Spring Rear Shackle R/H SK269							Shackle & Pin Kits
--	---------------	-----------------------	--------------------------------	--------------------------------	-----------------------------	------------------------------------	------------------------------------	--	--	--	--	--	--	--------------------

	SHUTTLE													
1981-on	Shuttle Van & Wagon - all models	BJ203	BJ252		TE727R	TE727R	TE728L	TE728L						

HILLMAN

1960-67	Hawk, Super Snipe				TE125L	TE125L	TE125R	TE125R						
1959-62	Minx, Gazelle series III,IIIA,IIIB,IIIC		KX185		TE125L	TE125L	TE125R	TE125R						
1962-67	Super Minx MKI,II,III,IV, Deluxe, Gazelle, series V,VA,VI, Husky series III	BJ31	BJ32		TE125L	TE125L	TE125R	TE125R						
1966-78	Hunter, Arrow, Royal, Hustler, Safari		BJ56	SX1130	TE125L	TE125L	TE125R	TE125R						BJ56 - can use BJ119

HINO

1967-on	TH80/300/360/400,TC30/300,8-10ton		KX312											
1967-on	TE11/61 6ton		KX314											
1973-on	Harrier KR301 6-6.5ton - King pin long size		KX319											King pin set 40 x 227mm
1973-on	Harrier KR320/360,BX,KP - King pin short size		KX319/1											King pin set 40 x 202mm
1964-on	Ranger KM300/320/400 3.5ton		KX315											
1969-on	Ranger KL320/400,HL,RL,KK		KX275											
1971-on	Ranger KQ,FQ300/400/320/340,KM410		KX317											
1971-on	Ranger KF,ZM,TC,KB,TV,TW,RE 8-11ton		KX318											

STEERING and SUSPENSION COMPONENTS



YEAR	MODEL	BALL JOINT UPPER	BALL JOINT LOWER / KING PIN SET	IDLER	TIE ROD END L/H OUTER	TIE ROD END R/H OUTER	TIE ROD END L/H INNER	TIE ROD END R/H INNER	RACK END	SIDE ROD	CENTRE ROD	DRAG LINK	PITMAN	NOTES/OTHER
1976-83	Ranger KL300 5ton		KX275		TE601L	TE601R								
1979-83	Ranger KL340 6.5ton		KX275		TE601L	TE601R								
	Ranger KL, KQ, KM				TE601L	TE601R								
1982-on	Ranger FD,FF,FT,GD,KD,KG,SD & Super Hawk FD,FF,GP176		KX321		TE726L	TE726R								
	FF192,FE193,FE197,FE,Raven		KX324											King pin set 40 x 227mm
HOLDEN - see GMH														
HONDA														
	ACCORD													
76-4/81	Accord SJ,SM,SV		BJ1207		TE681	TE681			RE851 male end					Ball joint with arm
5/81-9/83	Accord SY,SZ		RH-BJ4115 LH-BJ4116		TE681	TE681			RE849 male end					RE849 - overall length 295mm Ball joint with arm
6/83-1985	Accord AC,AD		RH-BJ4121 LH-BJ4122		TE681	TE681			RE852 male end					Ball joint with arm
1985-90	Accord CA	RH-BJ4130 LH-BJ4131	BJ279		TE681	TE681			RE849 male end					RE849 - overall length 295mm Ball joint with arm
		BJ6115 (rear) inc. arm	BJ5114 (rear) inc. arm											

H O N D A

STEERING and SUSPENSION COMPONENTS



YEAR	MODEL	BALL JOINT UPPER	BALL JOINT LOWER / KING PIN SET	IDLER	TIE ROD END L/H OUTER	TIE ROD END R/H OUTER	TIE ROD END L/H INNER	TIE ROD END R/H INNER	RACK END	SIDE ROD	CENTRE ROD	DRAG LINK	PITMAN	NOTES/OTHER
------	-------	------------------	---------------------------------	-------	-----------------------	-----------------------	-----------------------	-----------------------	----------	----------	------------	-----------	--------	-------------

1990-95	Accord CB	RH-BJ6181R LH-BJ6181L (1990-93) or RH-BJ5118R LH-BJ5118L (1994-on)	BJ6182 load carrying ball joint RH-BJ5125R LH-BJ5125L (1990-93) arm only RH-BJ5126R LH-BJ5126L (1994-on) arm only RH-BJ5117R LH-BJ5117L REAR inc. arm		TE962	TE961			RE970					
1995-97	Accord	RH-BJ5118R LH-BJ5118L inc. arm	BJ6182 load carrying ball joint		TE5621L	TE5621R			RE5621					
1998-02	Accord	RH - BJ5623R LH - BJ5623L inc. arm	BJ5618		TE5623L	TE5623R			RE5623					
	ACTY - see COMMERCIAL													
	CITY - see COMMERCIAL													
	CIVIC													
1973-75	Civic SB		RH-BJ4001 LH-BJ4002 inc. arm & bar		TE681	TE681			RE848 male end					Ball joint with arm and bar
1973-79	Civic EB series		BJ4111		TE681	TE681			RE848 male end					Ball joint with arm
1975-79	Civic SC,SE,SF,SG,SH,SK,SP		BJ4111		TE681	TE681			RE848 male end					Ball joint with arm

HONDA

STEERING and SUSPENSION COMPONENTS















YEAR	MODEL	BALL JOINT UPPER	BALL JOINT LOWER / KING PIN SET	IDLER	TIE ROD END L/H OUTER	TIE ROD END R/H OUTER	TIE ROD END L/H INNER	TIE ROD END R/H INNER	RACK END	SIDE ROD	CENTRE ROD	DRAG LINK	PITMAN	NOTES/OTHER
------	-------	------------------	---------------------------------	-------	-----------------------	-----------------------	-----------------------	-----------------------	----------	----------	------------	-----------	--------	-------------

1979-83	Civic SL,SR,SS,ST,WC,VC,VE		BJ4112		TE681	TE681			RE849 male end					RE849 - overall length 295mm Ball joint with arm
1983-87	Civic AG,AH,AJ,AK,AL,AT,AV,VJ,AR		RH-BJ1209 LH-BJ1210		TE681	TE681			RE850 male end					RE850 - overall length 317mm Ball joint with arm
1987-8/91	Civic EF,ED,EY	RH-BJ4238 LH-BJ4239	BJ279		TE718L	TE718R			RE869					Upper arm and ball joint
8/91-93	Civic EF,ED,EY	RH-BJ4238 LH-BJ4239	BJ279		TE718L	TE718R			RE6190					Upper arm and ball joint
1993-99	Civic EG,EH,EJ,EK	RH-BJ6191R LH-BJ6191L	BJ556		TE3560	TE3540			RE6190					
2000-on	Civic EU1,2,3,4 & ES1,2,3		BJ6242		TE6241	TE6241			RE5615					
	CONCERTO													
1987-92	Concerto													
	CRV													
1995-2001	CRV RD1 & RD2	RH-BJ5608R LH-BJ5608L inc. arm	BJ6192		TE3560	TE3540			RE6220					
2001-ON	CRV RD4 & RD5				TE6241	TE6241			RE6220					
	CRX													
7/83-10/87	CRX AE, AF, AS		RH-BJ6062R LH-BJ6062L		TE681 72mm long - straight	TE681			RE6060					
11/87-5/92	CRX EF,ED series 2 door coupe	RH-BJ4238 LH-BJ4239	BJ279		TE718L 180mm long with bend	TE718R			RE869 male end					Upper arm and ball joint
6/92-97	CRX EG series 2 door coupe		BJ556		TE3560 180mm long with bend	TE3540								
	HRV													
	HRV								RE6220					
	INTERGRA													

HONDA

STEERING and SUSPENSION COMPONENTS

YEAR	MODEL	BALL JOINT UPPER 	BALL JOINT LOWER / KING PIN SET 	IDLER 	TIE ROD END L/H OUTER 	TIE ROD END R/H OUTER 	TIE ROD END L/H INNER 	TIE ROD END R/H INNER 	RACK END 	SIDE ROD 	CENTRE ROD 	DRAG LINK 	PITMAN 	NOTES/OTHER	
1986-92	Integra DA		RH-BJ5135 LH-BJ5136 inc. arm		TE681 72mm long - straight	TE681			RE850 male end						RE850 - overall length 317mm
1993-97	Integra DB,DC		RH-BJ6191R LH-BJ6191L inc. arm		TE3560 180mm long with bend	TE3540			RE3010						
LEGEND															
1986-90	Legend KA		RH-BJ5613R LH-BJ5613L inc. arm		TE852L	TE851R			RE901						
1991-95	Legend		RH-BJ5122R LH-BJ5122L inc. arm RH-BJ5123R LH-BJ5123L (rear) inc. arm	BJ5613 ball joint only RH-BJ5616R LH-BJ5616L (rear) inc. arm	TE5622L	TE5622R			RE5622						
ODYSSEY															
1995-98	Odyssey RA1, RA2, RA3, RA4		RH-BJ6211R LH-BJ6211L		TE6211L	TE6211R			RE6210						
1999-02	Odyssey				TE5624	TE5624			RE5620						
PRELUDE															
1979-83	Prelude SN coupe				TE681	TE681			RE849 male end						RE849 - overall length 295mm Lower arm and ball joint
1983-91	Prelude AB,BA - 4WS (not BA4, BA5 or BA8)		BJ280	BJ279	TE681	TE681			RE853						RE853 - overall length 284mm
1987-91	Prelude BA4 coupe - four wheel steer		BJ350 (front) RH-BJ6165R LH-BJ6165L (rear)	BJ279	TE850R	TE850R			RE853 male end						RE853 - overall length 284mm
1987-91	Prelude BA5 coupe - four wheel steer		BJ350 (front) RH-BJ6165R LH-BJ6165L	BJ279 (front) BJ6166 (rear)	TE850R	TE850R			RE853 male end						RE853 - overall length 284mm

STEERING and SUSPENSION COMPONENTS



YEAR	MODEL	BALL JOINT UPPER	BALL JOINT LOWER / KING PIN SET	IDLER	TIE ROD END L/H OUTER	TIE ROD END R/H OUTER	TIE ROD END L/H INNER	TIE ROD END R/H INNER	RACK END	SIDE ROD	CENTRE ROD	DRAG LINK	PITMAN	NOTES/OTHER
------	-------	------------------	---------------------------------	-------	-----------------------	-----------------------	-----------------------	-----------------------	----------	----------	------------	-----------	--------	-------------

HONDA

		(rear)												
1991-on	Prelude BA8 coupe - four wheel steer		BJ5622											
1992-96	Prelude	RH-BJ5625R LH-BJ5625L inc. arm	BJ5622		TE5625L	TE5625R			RE5625					
1997-01	Prelude	RH-BJ5626R LH-BJ5626L inc. arm	BJ5626		TE5626L	TE5626R			RE5626					

HONDA - Commercial

10/82-86	Acty, TA,TB,VD,TN				TE681	TE681	TE682L	TE682L						
11/81-6/86	City, AA,VF,FA,GA - exc. Turbo				TE681	TE681			RE849 male end					RE849 - overall length 295mm
4/84-6/98	City, AA,VF,FA,GA - inc. Turbo				TE681	TE681			RE850 male end					RE850 - overall length 317mm
1996-98	City, SX8				TE6231	TE6231								

HYUNDAI

HYUNDAI

ACCENT														
1995-99	Accent		BJ925		TE965R	TE965R			RE3723					
2000-on	Accent													
EXCEL														
1986-90	Excel X1		RH-BJ1169 LH-BJ1170		TE552R 70.35mm	TE552R 70.35mm								RE1855 - overall length 300mm
1989-94	Excel X2 - power steer		BJ1409 2 bolt mount		TE552R 70.35mm	TE552R 70.35mm								RE971 - overall length 310mm
1990-6/96	Excel X2 - manual steer		BJ1409 2 bolt mount		TE552R 70.35mm or TE964	TE552R 70.35mm or TE964								RE1855 - overall length 300mm RE888 - overall length 320mm

RACK END FITMENT
Excel series rack ends have been found to vary greatly. Please check measurements to determine fitment.
RE1855 - Female 300mm 14x1.5 TRE thread
RE971 - Male 310mm 14x1.5 TRE thread
RE888 - Male 320mm 12x1.25 TRE thread

STEERING and SUSPENSION COMPONENTS



YEAR	MODEL	BALL JOINT UPPER	BALL JOINT LOWER / KING PIN SET	IDLER	TIE ROD END L/H OUTER	TIE ROD END R/H OUTER	TIE ROD END L/H INNER	TIE ROD END R/H INNER	RACK END	SIDE ROD	CENTRE ROD	DRAG LINK	PITMAN	NOTES/OTHER
------	-------	------------------	---------------------------------	-------	-----------------------	-----------------------	-----------------------	-----------------------	----------	----------	------------	-----------	--------	-------------

HUMBER

					80.2mm	80.2mm				RE974 - Male 325mm 14x1.5 TRE thread				TE964 - 10mm longer than TE552R
97-00	Excel X3		BJ1409 2 bolt mount		TE552R 70.35mm or TE964 80.2mm	TE552R 70.35mm or TE964 80.2mm								RE1855 - overall length 300mm RE888 - overall length 320mm TE964 - 10mm longer than TE552R
GRANDEUR														
5/91-92	Lantra KF		BJ1409 2 bolt mount		TE963	TE963			RE972 male end					RE972 - overall length 31.8cm BJ1409 - 2 bolt mount
1992-on	Lantra KF		BJ925 press in		TE964 80.2mm	TE964 80.2mm			RE973 male end					RE973 - overall length 32.4cm BJ925 - press in
S COUPE														
6/90-3/96	S Coupe		BJ1409 2 bolt mount		TE552R 70.35mm	TE552R 70.35mm			RE1888 female end					RE1888 - overall length 30cm
SONATA														
1/89-10/93	Sonata AF		BJ925 press in		TE965	TE965			RE974 male end					RE974 - overall length 32.5cm
10/93-98	Sonata DF		BJ802 front ball joint only or RH-BJ4151 LH-BJ4150 control arm rear of vehicle BJ803 ball joint only 2 required each side		TE965	TE965			RE975 male end					RE975 - overall length 34.4cm
1999-02	Sonata	BJ5438	BJ5138		TE5389L	TE5389R			RE5738					
HUMBER														
1948-49	Hawk MK III		KX73		TE91L	TE91L	TE91R	TE91R						
1950-57	Hark MK IV,V,VI		KX73		TE117L	TE117L	TE117R	TE117R						

STEERING and SUSPENSION COMPONENTS



YEAR	MODEL	BALL JOINT UPPER	BALL JOINT LOWER / KING PIN SET	IDLER	TIE ROD END L/H OUTER	TIE ROD END R/H OUTER	TIE ROD END L/H INNER	TIE ROD END R/H INNER	RACK END	SIDE ROD	CENTRE ROD	DRAG LINK	PITMAN	NOTES/OTHER
------	-------	------------------	---------------------------------	-------	-----------------------	-----------------------	-----------------------	-----------------------	----------	----------	------------	-----------	--------	-------------

1953-58	Supersnipe MK VI				TE26L	TE26R	TE26R	TE26L						
1957-60	New Hawk Series I, New Super Snipe I,II		KX73		TE125L	TE125L	TE125R	TE125R						
1960-67	Hawk Series IA,II,III,IV, Super Snipe III,IV,V		KX199		TE125L	TE125L	TE125R	TE125R						
1962-67	Vogue Mkl,II,III,IV, Sceptre Mkl,II	BJ31	BJ32		TE125L	TE125L	TE125R	TE125R						

INTERNATIONAL 4WD

1974-80	Scout, Traveller	305-112	10253		310-270 (ES2052R)	310-288 (ES2053R)								310-270 - has hole for steering damper
---------	------------------	---------	-------	--	-------------------	-------------------	--	--	--	--	--	--	--	--

INTERNATIONAL TRUCKS

1950-68	190 series with FA80 & FA91 axles		300-110		TE174L	TE174R								King pin set with metal bushes 1.234" x 7.66"
1950-68	190 series with FA100 axle 9000lb				TE419L	TE419R								
1958-66	170,180,1890 series with FA65 axle		300-110		TE174L	TE174R								King pin set with metal bushes 1.234" x 7.66"
1961-73	106,110,120,130,700,800,900,1100,1200, 1300, series with FA1 & FA10 axles		300-112		TE175L	TE175R								King pin set with metal bushes 0.8605" x 5.44"
1962-68	C150,1500,M1200,1400,1500 series with FA28 & FA48 axles 4700lb		300-118		310-100	310-101								King pin set with metal bushes 1.1095" x 6.25"
1962-72	CO1600,1700,1750,1800,1850 & F1800,1850, 1900,2000, series with FA105,FA208 & FA209 axles		300-159		TE419L	TE419R								Twin keyway king pin set with metal bushes - 1.433" x 8.50"
1965-75	500,1200D,1210,1300D,1310,1500,1510 with FA12 & FA28 axles		300-118		310-195	310-196								King pin set with metal bushes 1.1095" x 6.25"
1965-77	1600,1700,1750,1800,1850 ACCO 1710A, 1730A series with FA60 & FA69 axles		300-110		TE174L	TE174R								King pin set with metal bushes 1.234" x 7.66"
1965-77	1600,1700,1750,1800,1850 ACCO 1710A, 1730A series with FA68 & FA72 5000 & 5500lb axles		300-120		TE174L	TE174R								King pin set with metal bushes 1.234" x 6.75"
1966-86	CO1600,1700,1750,1800,1850,F1800, 1850 with FA139,FA309 & FA329 axles		300-205		310-215	310-216								Twin keyway king pin set with metal bushes - 1.603" x 9.66"
1966-86	CO1600,1700,1750,1800,1850,F1800,		300-221		310-215	310-216								Single offset keyway king pin set

STEERING and SUSPENSION COMPONENTS



YEAR	MODEL	BALL JOINT UPPER	BALL JOINT LOWER / KING PIN SET	IDLER	TIE ROD END L/H OUTER	TIE ROD END R/H OUTER	TIE ROD END L/H INNER	TIE ROD END R/H INNER	RACK END	SIDE ROD	CENTRE ROD	DRAG LINK	PITMAN	NOTES/OTHER
	1850 with FA139,FA309 & FA329 axles													1.6085" x 9.61"
1966-71	C1820,CD1820,C1840,CD1840		300-110		TE174L	TE174R								King pin set with metal bushes 1.234" x 7.66"
1966-78	D400,DC400,DF400,D405,DCT405,CO4000,COF4000,COT4000,CO4070A, Transtar with FA119 axle		300-188		310-215	310-216								Twin keyway king pin set with metal bushes - 1.6085" x 9.610"
1966-12/84	ACCO 1810A,1820,1830, 1830A, 1840,1950, F1910A,F1912A, 2050A,F2052A,F2152A with FA100 Australian axle		KX244	(x 2 = Twin Axle)										King pin set with metal bushes (+ 1.732" Stepped Pin)
1971-77	D1810,D1830,D1910,D1950 with FA65 axle		300-110		TE174L	TE174R								King pin set with metal bushes 1.234" x 7.66"
1972-77	ACCO 1710A,1730A with FA65,FA80,FA91 FA98 & FA99 axles 7500lb		300-110		TE174L	TE174R								King pin set with metal bushes 1.234" x 7.66"
1972-86	1900,1950,F1950,T1950,2000,D,DC,DCF400, 405,F1800,COF4070A,4200,1700,1750,1850,1900, 1950 with FA125,FA215,FA218,FA219,FD215, & FD218 axles		300-182		TE419L	TE419R								Twin keyway king pin set with metal bushes - 1.7935" x 9.12"
1973-80	Scout II 2WD with FA3 axle Scout II 4WD 100, 150 4WD				310-288 18 TPI thread	310-270 12 TPI thread								310-270 - has hole for steering damper
1973-80	Scout II 2WD with FA3 axle Scout II 4WD				310-288 18 TPI thread	310-270 12 TPI thread								310-270 - has hole for steering damper
	to suit RABA axle FA339 & FA337		KX743											
	to suit FA339 axle where triple keyway pin required		KX339											
1979-86	'T' line - T2650,T2670,TF2650,TF2670, TK2650, TK2670 & 'S' line with single keyway king pin & Rockwell FF931 axles to chassis# L00672		300-223 one cotter		310-215	310-216						310-317		King pin set with metal bushes 1.6085" x 9.66"
1979-86	'T' line - T2650,T2670,TF2650,TF2670, TK2650, TK2670 & 'S' line with double keyway king pin from chassis# L00672		300-205 two cotter		310-215	310-216						310-317		Twin keyway king pin set with metal bushes - 1.6085" x 9.66"
Also KX663 with 3 cotters will suit all S-Line applications														
ISUZU														
NOTE: MODELS KB20,KB25,KB26,KB27,KB38 - see CHEVROLET LUV														
1961-84	ELF TL,TK,TL,BL		KX220		TE607L	TE607R								King pin set 25 x 178mm

STEERING and SUSPENSION COMPONENTS



YEAR	MODEL	BALL JOINT UPPER	BALL JOINT LOWER / KING PIN SET	IDLER	TIE ROD END L/H OUTER	TIE ROD END R/H OUTER	TIE ROD END L/H INNER	TIE ROD END R/H INNER	RACK END	SIDE ROD	CENTRE ROD	DRAG LINK	PITMAN	NOTES/OTHER
------	-------	------------------	---------------------------------	-------	-----------------------	-----------------------	-----------------------	-----------------------	----------	----------	------------	-----------	--------	-------------

Nissan

1971-on	ELF KA,KUD,TL,TK 1.25-1.75ton		KX221		TE607L	TE607R								King pin set 22 x 152mm
1973-on	SPZ,TD,TP,DL,VP,SR,TKM 8-11ton		KX222		TE607L	TE607R								King pin set 50 x 250mm
1980-on	ELF TLD56,KT		KX032		TE607L	TE607R								
1980-84	ELF TLD44 2500kg		KX268		TE607L	TE607R								King pin set 25 x 178mm
1961-84	ELF 350, KS				TE607L	TE607R								
1984-on	FSR series 5ton		KX222		TE607L	TE608R								King pin set 50 x 250mm
1984-on	FTR series 7ton		KX223		TE722L	TE722R								
	TFS 4WD - see GMH Rodeo 4WD													
1978-84	JBR500, JCR500 - 6ton		KX271											King pin set 45 x 244.5mm
1978-on	FE211, FE334, FE339		KX534											King pin set 28 x 180mm
1977-84	KS21, KT25, KT26 3000kg, KS32 4000kg		KX269		TE607L	TE607R								King pin set 30 x 178mm
	MU	BJ805	BJ282		TE5281L	TE5281R	TE5281R	TE5281L						
1984-on	NKR, NPR 1.5-4ton		KX231		TE683L	TE683R								
1984-89	NPS300 4x4		KX233		TE683L									
1976-84	SBR450,SBR422 Forward Control 4600kg SCR480 Forward Control 6000kg		KX270		TE608L	TE608R								King pin set 35 x 199mm
1973-85	SP, VP 8 & 12ton		KX272		TE609L	TE609R								King pin set 50 x 252mm

Jaguar

1936-48	2.5, 3.5, MKIV SS (conventional axle)				TE26L	TE26R							TE26L & R ends only	
1949-54	2.5, 3.5, MKV, XK120				TE26L	TE26L	TE26R	TE26R						
1956-59	2.4 MKI Chassis # 900001-912621 & 940001-943266	BJ47												

STEERING and SUSPENSION COMPONENTS



YEAR	MODEL	BALL JOINT UPPER	BALL JOINT LOWER / KING PIN SET	IDLER	TIE ROD END L/H OUTER	TIE ROD END R/H OUTER	TIE ROD END L/H INNER	TIE ROD END R/H INNER	RACK END	SIDE ROD	CENTRE ROD	DRAG LINK	PITMAN	NOTES/OTHER
------	-------	------------------	---------------------------------	-------	-----------------------	-----------------------	-----------------------	-----------------------	----------	----------	------------	-----------	--------	-------------













1963-67	4.2 MKX				TE134L	TE135R	TE136R	TE134L						
1955-69	2.4, 3.4, 3.8 MKII, 240, 340	BJ154	BJ155											Ball joint repair kit - BJ155RK
1964-71	MK10 4.2, 420G	BJ154	BJ155											Ball joint repair kit - BJ155RK
DAIMLER														
1962-69	2.5ltr V8	BJ154	BJ155											Ball joint repair kit - BJ155RK
1969-79	Sovereign, Double Six (Series I, II)	BJ154	BJ155		TE527R	TE527R								Ball joint repair kit - BJ155RK
1979-on	Sovereign, Double Six (Series III - to VIN 345389)	BJ154	BJ155		TE527R	TE527R								Ball joint repair kit - BJ155RK
E TYPE														
1961-71	E Type series I & II - 6cyl	BJ154	BJ155											Ball joint repair kit - BJ155RK
1971-76	E Type series III - V12	BJ154	BJ155		TE527R (1969-on)	TE527R (1969-on)								Ball joint repair kit - BJ155RK
XJ SERIES														
1968-on	XJ6, XJ12, XJS - to vin# 107864	BJ154	BJ155		TE527R	TE527R								Ball joint repair kit - BJ155RK
1968-on	XJ6, XJ12, XJS - from vin# 107865	BJ154	BJ155		TE1840	TE1840								Ball joint repair kit - BJ155RK

PEOP

JEEP														
CJ SERIES														
1957-72	CJ5, CJ6				TE189R	TE190L	TE189R	TE190L						
1972-83	CJ5, CJ6, CJ7, CJ8	305-112	10253		TE190L	TE189R	DS911 23.94"	TE189R to pitman arm						
1982-86	CJ5, CJ6, CJ7, CJ8	305-112	10253		TE190L	TE189R	DS1070 24.64"	TE189R to pitman arm						
CHEROKEE/WAGONEER/COMANCHE														
1974-90	Cherokee Chief, J10, J20	305-112	10253											
1974-90	Cherokee, Wagoneer, Comanche (1986-92)	305-112	10253											
1991-97	Cherokee, Wagoneer	10458	10459											
COMMANDO/JEEPSTER														

STEERING and SUSPENSION COMPONENTS



YEAR	MODEL	BALL JOINT UPPER 	BALL JOINT LOWER / KING PIN SET 	IDLER 	TIE ROD END L/H OUTER 	TIE ROD END R/H OUTER 	TIE ROD END L/H INNER 	TIE ROD END R/H INNER 	RACK END 	SIDE ROD 	CENTRE ROD 	DRAG LINK 	PITMAN 	NOTES/OTHER
------	-------	---	--	--	---	--	--	--	---	---	---	--	---	-------------

1962-73	Commando, Jeepster 4WD - with steering gear in front of axle	305-112	10253											
	WRANGLER													
1987-97	Wrangler 4WD	10458	10459											

KENWORTH

1970-85	C500,K100,L700,W900 with FH901 & FL901 16000 & 18000lb Rockwell axle		300-210		310-228	310-229						346-265 27.31" (centre to centre) 346-266 26.75" (centre to centre)		Twin keyway king pin set with metal bushes - 1.999" x 11.04"
1971-80	C500,K100,L700,W900 with FL931 18000lb Rockwell axle		300-216		310-283	310-284						346-265 27.31" (centre to centre) 346-266 26.75" (centre to centre)		Twin keyway king pin set with metal bushes - 1.9999" x 11.21"
1971-80	C500,K100,L700,W900 with FF931 12000lb Rockwell axle		300-232		310-222	310-223								Twin keyway king pin set with metal bushes - 1.7935" x 10.392"
1980-on	All models with Rockwell FF931 axle (single & duel steer)		300-232											Twin keyway king pin set with metal bushes - 1.7935" x 10.392"

KIA

1986-on	Besta	BJ250	BJ251		TE979	TE979								
	Carnival													
1990-on	Ceres 2WD & 4WD k670, k672, k675, k676				TE6732L LH Thread	TE6732R RH Thread								
	Credos													
7/93-on	Mentor		BJ550		TE2210	TE2210								
1990-on	Pride K124, K125, K126, K127, K128				TE3624R	TE3624R								
	Rio													

STEERING and SUSPENSION COMPONENTS



YEAR	MODEL	BALL JOINT UPPER	BALL JOINT LOWER / KING PIN SET	IDLER	TIE ROD END L/H OUTER	TIE ROD END R/H OUTER	TIE ROD END L/H INNER	TIE ROD END R/H INNER	RACK END	SIDE ROD	CENTRE ROD	DRAG LINK	PITMAN	NOTES/OTHER
------	-------	------------------	---------------------------------	-------	-----------------------	-----------------------	-----------------------	-----------------------	----------	----------	------------	-----------	--------	-------------

1993-97	Sephia		BJ2006											
1998-01	Sephia													

KIA - Commercial

all	KIA - Asia Bus		KX605											
2004-on	Sorento 4WD													
7/93-on	Sportage	BJ4389 inc. arm	BJ701	SX2320	TE1921L	TE1921R	TE1922L	TE1922R						

LADA

1972-on	1200, 1300, 1500, 1600	BJ768	BJ4082		TE1118	TE1118	TE3003L	TE3003R						TR3011	
1986-on	Samara		BJ1111 2 bolt mount		TE2275	TE2274	TE4046	TE4046							
1983-on	Niva	BJ768	BJ768 3 bolt mount		TE1118 short tie rod ends	TE1118	TE2276 long tie rod ends	TE2276						TR4011	

LANDROVER

LANDROVER CHASSIS IDENTIFICATION
The Landrover Chassis Identification number is located on the Left, Rear section of the chassis above the shackle plate.

1948-62	Series 1 & 2 (up to Axle Suffix "D") 86,88,107,109NC 25/35 cwt.				TE79L	TE79R	TE79R	TE79L					TE79L front TE79R rear	Drag Link ends only
1962-75	Series 1, 1A, 2, 2A (up to Axle Suffix "D")				TE79L	TE79R	TE79R	TE79L					TE79L front TE79R rear	Drag Link ends only
1975-on	Series 3 (Axle Suffix "E")				TE1569L	TE1569R	TE1569R	TE1569L					TE1569L front TE1569R rear	Drag Link ends only
3/1984-on	Series 90, 100, 110	BJ223 self level unit	BJ223 self level unit BJ224 rear lower		TE626R 11/16"x16 RHT	TE626R 11/16"x16 RHT or TE626L 11/16"x16 LHT							TE626R end only	All tie rod ends are RH thread. Adjustment is achieved through the ADJUSTING SHAFT until 1993-on when TE626L is used for adjustment. Check threads before ordering.

LANDROVER

STEERING and SUSPENSION COMPONENTS

YEAR	MODEL	BALL JOINT UPPER	BALL JOINT LOWER / KING PIN SET	IDLER	TIE ROD END L/H OUTER	TIE ROD END R/H OUTER	TIE ROD END L/H INNER	TIE ROD END R/H INNER	RACK END	SIDE ROD	CENTRE ROD	DRAG LINK	PITMAN	NOTES/OTHER
------	-------	------------------	---------------------------------	-------	-----------------------	-----------------------	-----------------------	-----------------------	----------	----------	------------	-----------	--------	-------------













1995-on	DEFENDER Defender		BJ224 rear lower		TE626R 11/16"x16 RHT	TE626L 11/16"x16 LHT								
1991-on	DISCOVERY Discovery		BJ224 rear lower		TE626R 11/16"x16 RHT	TE626R 11/16"x16 RHT								
1998-on	FREELANDER Freelander				TE5292L	TE5293R								
12/1970-on	RANGE ROVER Range Rover	BJ223 self level unit	BJ223 self level unit BJ224 rear lower		TE626R 11/16"x16 RHT	TE626R 11/16"x16 RHT or TE626L 11/16"x16 LHT	<p>SX181A Up to 1992</p> <p>SX181B 1993-on</p> <p>SX181K Power Steering Only</p>			TE626R nd only	SX181K pitman arm repair kit p/steer only	All tie rod ends are RH thread. Adjustment is achieved through the ADJUSTING SHAFT until 1993-on when TE626L is used for adjustment. Check threads before ordering.		
														SX181A pitman arm up to 1992

LEYLAND (inc. Austin, Mini, Morris, M.G.)														
AUSTIN														
1958-71	Healy Sprite	SX47	SX48		TE126R	TE126R								
1962-74	Austin 100,1100S,1300 MkI,II,III				TE179R	TE179R								
1964-77	Austin 1800, 2200 MkI & Mk11, Kimberly, Tasman X6	BJ78	BJ78		TE125R	TE125R								Knuckle joint (Front & Rear) - BJ79
1962-66	Freeway MKI, MKII	SX39	SX19		TE126R	TE126R								
1967-72	3 litre				TE125R	TE125R								
1973-77	Allegro 1100,1300,1500,1750	BJ37 repair kit	BJ38 repair kit		TE179R	TE179R								Knuckle joint (Front & Rear) - BJ82 BJ167K - upper & lower combined repair kit
		U/L RK combined - BJ167K												

250-401

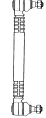
STEERING and SUSPENSION COMPONENTS



YEAR	MODEL	BALL JOINT UPPER 	BALL JOINT LOWER / KING PIN SET 	IDLER 	TIE ROD END L/H OUTER 	TIE ROD END R/H OUTER 	TIE ROD END L/H INNER 	TIE ROD END R/H INNER 	RACK END 	SIDE ROD 	CENTRE ROD 	DRAG LINK 	PITMAN 	NOTES/OTHER
1959-10/80	Mini Range 850/1100, Minor, Clubman series, Moke, Cooper & Cooper 'S'	BJ29	BJ29		TE179R	TE179R								BJ29 - one wheel kit to repair both upper & lower joints Knuckle Joint (Front & Rear) - BJ33
	MINI													
1959-10/80	Mini - all models	BJ29	BJ29		TE179R	TE179R								BJ29 - one wheel kit to repair both upper & lower joints Knuckle Joint (Front & Rear) - BJ33
	MORRIS													
1954-59	Oxford, Traveller, Cowley, Isis				TE126R	TE126R								
1958-62	Major 1500 Series I,II				TE126R	TE126R								
1962-64	Major Elite Mk III				TE126R	TE126R								
1959-71	Minor 1000 Series III, chassis# 566384 on (RHD) & chassis# 567389 on (LHD) series V, 1000 utility van chassis# 65376 on				TE126R	TE126R								
6/62-4/72	Morris 1100, 1300	BJ37 repair kit	BJ38 repair kit		TE179R	TE179R								Knuckle joint (Front & Rear) - BJ82 BJ167K - upper & lower combined repair kit
		U/L RK combined - BJ167K												
1969-77	Morris Nomad, Marina, Maxi 1500,1750				TE179R	TE179R								
	M.G.													
1956-72	Magnette MGA 1500,1600				TE126R	TE126R								
1957-59	Magnette ZB chassis# 25586 on (RHD) & chassis# 26102 on (LHD)				TE126R	TE126R								
1956-62	Midget 948				TE126R	TE126R								
1962-72	Midget 1098, 1275		KX624		TE126R	TE126R								
1972-74	Midget 1098, 1275		KX624		TE157L	TE157L								
1974-on	Midget 1098, 1275				TE1572	TE1572								
1963-72	MGB, MGB-GT, MGC, MGC-GT		KX650		TE126R	TE126R								
1972-80	MGB, MGB-GT, MGC, MGC-GT		KX650		TE195R	TE195R								

STEERING and SUSPENSION COMPONENTS



YEAR	MODEL	BALL JOINT UPPER	BALL JOINT LOWER / KING PIN SET	IDLER	TIE ROD END L/H OUTER	TIE ROD END R/H OUTER	TIE ROD END L/H INNER	TIE ROD END R/H INNER	RACK END	SIDE ROD	CENTRE ROD	DRAG LINK	PITMAN	NOTES/OTHER
1997-on	MGF													
2000-on	MG 'TD2000'								RE868					
	P76													
all	Leyland P76				TE4893R	TE4893R								
LEYLAND - Commercial														
1956-73	4-60F,5-60F,6-60F,7-20F,7-50F,7-60F,7-80F - 4,5,6,7 ton (Australia)							TE337R					TE337R Rear	
1955-67	FF series, Forward Control, FFK100,140,240,300,340,360 5,7,12,15,17,18 ton							TE337R					TE337R Rear	TE337R - have a very unique thread! 3.625 long BLD .660 ** BHD.793 ** Thread 5.875x14 TPI
1964-70	FG Redline series, FGK100 & 900FG to chassis# 378797 5ton							TE337R					TE337R Rear	
LEXUS														
1993-96	ES300 Sedan		104218		ES3306	ES3306								
LINCOLN														
1980-81	Continental - rear wheel drive		10327											
1995-97	Continental - front wheel drive - V8 4.6lt		104217											
1980-83	Mark III, IV, V, VI		10327											
1980-94	Town Car		10327											
LOTUS - see PROTON (Satria)														
MACK														
1969-91	Value Liner, Super Liner, Cruise Liner, DM400,DM600,DM606S,DM607S,MB400,MB600,MR400,MR600,R400,R600,R685R,R686ST,R700, RD600,RD700,WL700L&S,U600,F700 with FA(W)536 FA(W)537 10000 & 12000lb axles & fine or coarse thread tie rod ends.		300-231		310-228 fine thread 1 1/4" x 12 TPI shank TE419L coarse thread 1 1/8" x 12 TPI shank	310-229 fine thread TE419R coarse thread								Tapered king pin set with metal bushes - 1.625" x 7.470"

STEERING and SUSPENSION COMPONENTS



YEAR	MODEL	BALL JOINT UPPER	BALL JOINT LOWER / KING PIN SET	IDLER	TIE ROD END L/H OUTER	TIE ROD END R/H OUTER	TIE ROD END L/H INNER	TIE ROD END R/H INNER	RACK END	SIDE ROD	CENTRE ROD	DRAG LINK	PITMAN	NOTES/OTHER
------	-------	------------------	---------------------------------	-------	-----------------------	-----------------------	-----------------------	-----------------------	----------	----------	------------	-----------	--------	-------------

1975-94	R600L,R600LS,R700L,RWL700S,RWS700S,WL700L,WL700LS,WS700L,WS700LS with FF931 12000lb axles		300-232		310-222	310-223								Twin keyway king pin set with metal bushes - 1.793" x 10.390"
1975-94	R600L,R600LS,R700L,RWL700S,RWS700S,WL700L,WL700LS,WS700L,WS700LS with FF931 18000lb axles		300-216		310-283	310-284								Twin keyway king pin set with metal bushes - 1.999" x 11.210"

**M
a
z
d
a**

MAZDA														
	800/1000													
1964-68	800 Familia BS,FS,MS,SS,SSA 1000 Familia BPAV,MP,SP	RH-BJ95 LH-BJ96	RH-BJ97 LH-BJ98		TE192L	TE192L	TE191R	TE191R						
	1200/1300													
1968-70	1200 Familia STA,SPB,BPBV,BTAV,MOIA		BJ83		TE447L	TE447L	TE448R	TE448R						
1970-72	1300 Familia Presto STB,FA3T		BJ83		TE479L	TE479L	TE480R	TE480R					SX5224	SX5224 - 28 splines and 1 master spline
1972-10/75	1300 Familia Presto FA3T		BJ83		TE479L	TE479L	TE505R	TE505R					SX5224	SX5224 - 28 splines and 1 master spline
10/75-1977	1300 Familia Presto FA3T		BJ83	SX1234	TE508L	TE508L	TE515R	TE515R					SX5226	
	121/121L - 2 door coupe													
1975-77	121, 121L - CD2 models 1.8lt		BJ247 screw in	SX1233	TE512L	TE512L	TE513R	TE513R					SX5243	BJ247 - 41mm diameter
1977-81	121,121L - CD3&5 models 1.8/2.0lt		BJ248 screw in	SX1233	TE512L	TE512L	TE513R	TE513R					SX5243	BJ248 - 43mm diameter
	121 - hatch													
1987-92	121 hatch DA 1.3lt - manual steer		BJ330 ball joint only		TE3624R	TE3624R			CGR-RE891 VGR-RE892					CGR rack has constant gear ratio VGR rack has variable gear ratio
1987-92	121 hatch DA 1.3lt - power steer		BJ330 ball joint only		TE3624R	TE3624R			RH-RE893R LH-RE894L					
1992-94	121		BJ4310 ball joint inc. arm											NOTE - in some applications BJ4310 can be too short. Check length. If too short use BJ4300. (BJ4300 is 10mm longer than BJ4310)
1994-on	121		BJ4300 ball joint inc. arm											NOTE - in some applications BJ4300 can be too long. Check length. If too long use BJ4310. (BJ4310 is 10mm shorter than BJ4300)
	1500/1800													

STEERING and SUSPENSION COMPONENTS



YEAR	MODEL	BALL JOINT UPPER	BALL JOINT LOWER / KING PIN SET	IDLER	TIE ROD END L/H OUTER	TIE ROD END R/H OUTER	TIE ROD END L/H INNER	TIE ROD END R/H INNER	RACK END	SIDE ROD	CENTRE ROD	DRAG LINK	PITMAN	NOTES/OTHER
1966-77	B1500 (BUD) B1600 (BNA,BNB)	BJ99	BJ100		TE192L	TE192L	TE191R	TE191R						
1965-68	1500 sedan - SUA, Luce	BJ99	BJ100		TE192L male	TE192L male	TE191R male	TE191R male			TR421			Male thread tie rod ends
1968-73	1500, 1800 sedan - SUA, SVA, Luce	BJ99	BJ100		TE443L female	TE443L female	TE445R female	TE445R female			TR421			Female thread tie rod ends
1977-81	323 series (inc. Astina) 323 FA4, FA5 - rear wheel drive TS,TV,US,UV		BJ149	SX1235 idler arm	TE514L	TE514L	TE515R	TE515R					SX5235	
1980-85	323 BD1031, BD1051, BD1052 - front wheel drive - manual steer		BJ180 or RH-BJ180ARMRH LH-BJ180ARMLH arm only		TE562L	TE562R			RE842 male end					BJ180 - 12mm ball bolt clip groove
1980-85	323 BD1031, BD1051, BD1052 - front wheel drive - power steer		BJ180 or RH-BJ180ARMRH LH-BJ180ARMLH arm only		TE562L	TE562R			RE843 male end					BJ180 - 12mm ball bolt clip groove
1985-90	323 BF, BW, BV - manual steer		BJ330		TE3624R	TE3624R			CGR-RE891 VGR-RE892					CGR rack has constant gear ratio VGR rack has variable gear ratio
1985-90	323 BF, BW, BV - power steer		BJ330		TE3624R	TE3624R			RH-RE893R LH-RE894L					
1989-94	323 BG inc. Astina		BJ2006 (16mm spigot) or BJ1572 (18mm spigot)		TE840	TE840			RE1550 (1989-94) m/steer RH-RE1551R LH-RE1551L (1989-94) p/steer RH-RE981 LH-RE980 (1994-on)					TE840 has larger taper than TE3624R BJ2006 - spigot diam 16mm with 13mm slot BJ1572 - spigot diam 18mm with 14mm slot
1994-on	Astina BA				TE969	TE969			RH-RE981 LH-RE980					

Mazda

STEERING and SUSPENSION COMPONENTS















YEAR	MODEL	BALL JOINT UPPER	BALL JOINT LOWER / KING PIN SET	IDLER	TIE ROD END L/H OUTER	TIE ROD END R/H OUTER	TIE ROD END L/H INNER	TIE ROD END R/H INNER	RACK END	SIDE ROD	CENTRE ROD	DRAG LINK	PITMAN	NOTES/OTHER
------	-------	------------------	---------------------------------	-------	-----------------------	-----------------------	-----------------------	-----------------------	----------	----------	------------	-----------	--------	-------------

1994-9/98	Protégé (BH)				TE969	TE969				RH-RE981 LH-RE980				
10/98-6/02	Protégé (BJMW)													
	626 series (inc. MX6)													
1970-74	626 SU2A, SNA		BJ83		TE479L	TE479L	TE480R	TE480R						
1974-75	626 SNA, SV2A		BJ83		TE510L	TE510L	TE482R	TE482R						10mm bolt thread
1975-77	626 SNA	BJ99	BJ249 press in		TE511L	TE511L	TE513R	TE513R						12mm bolt thread
9/78-1980	626 CB2 - rear wheel drive		BJ149	SX1236	TE514L	TE514L	TE568R	TE568R						TE568R overall length 201mm
1980-10/82	626 CB2 - rear wheel drive		BJ149	SX1236	TE514L	TE514L	TE515R	TE515R						TE515R overall length 177mm
9/82-2/87	626 GC - front wheel drive - manual steer NOT four wheel steering		BJ306		TE678	TE678				RH-RE844R LH-RE844L				RE844R - overall length 275mm RE844L - overall length 295mm
9/82-2/87	626 GC - front wheel drive - power steer NOT four wheel steering		BJ306		TE678	TE678				RH-RE895R LH-RE896L				
2/87-12/91	626 GD - front wheel drive - manual steer		BJ306		TE678	TE678				RE897				
2/87-12/91	626 GD - front wheel drive - power steer		BJ306		TE678	TE678				RE898				
2/87-10/91	626 GDEA 2.2lt - four wheel steering		BJ306		TE678 (front) TE717R (rear)	TE678 (front) TE717R (rear)				RE897 (front)				
10/91-on	626 GE/EE - two wheel steering		RH-BJ4152 LH-BJ4153		TE970	TE970				RH-RE982 LH-RE983				
	808 / SAVANNA													
71-10/75	808 STC, SN3A, SNA4A Savanna (STC, SU4A, SN3A, SN4A, STCV, SU4AV, SN3AV) inc. VAN		BJ126 press in	SX1235	TE481L	TE481L	TE482R	TE482R					** Check Pitman Arm Measurements prior to ordering	SX5229 ** Tie rod ends with 10mm ball joint BJ126 - 41mm diameter
10/75-77	808 STC, SNA Savanna (STC, STCV, SN4A, SN3AV) inc. VAN		BJ126 press in	SX1235	TE512L	TE512L	TE513R	TE513R			SX5229 - 28 splines & 1 master spline 22-23mm spline diameter		SX1290 **	Tie Rod Ends with 12mm ball bolt BJ126 - 41mm diameter

M
a
n
d
a
t
a

STEERING and SUSPENSION COMPONENTS



YEAR	MODEL	BALL JOINT UPPER 	BALL JOINT LOWER / KING PIN SET 	IDLER 	TIE ROD END L/H OUTER 	TIE ROD END R/H OUTER 	TIE ROD END L/H INNER 	TIE ROD END R/H INNER 	RACK END 	SIDE ROD 	CENTRE ROD 	DRAG LINK 	PITMAN 	NOTES/OTHER
------	-------	--	---	--	--	---	---	---	--	--	--	---	---	-------------

a

1977-78	808 STC, SNA Savanna (STC, STCV, SN4A, SN3AV) inc. VAN		BJ249 press in	SX1235	TE512L	TE512L	TE513R	TE513R		SX1290 - 36 splines & 1 master spline 23-24.3mm spline diameter		SX1290 **	Tie Rod Ends with 12mm ball bolt BJ249 - 43mm diameter
78-10/80	Savanna RX7,SA22C (REIZA) Sports Coupe		BJ149		TE508L	TE508L	TE515R	TE515R					
	929 series												
1966-73	929/929L 1500/1800	BJ99	BJ100		TE443L	TE443L	TE445R	TE445R					
10/72-74	929, 929L LA2VS with 10mm ball pin tie rod		BJ126 press in	SX1233 idler arm OEM2002K idler bush	TE481L (to 10/75)	TE481L (to 10/75)	TE483R (to 10/75)	TE483R (to 10/75)					SX5242 Tie rod end bolt 10mm
1974-77	929, 929L LA2, LA3 with 12mm ball pin tie rod		BJ126 press in	SX1233 idler arm OEM2002K idler bush	TE512L (10/75-on)	TE512L (10/75-on)	TE513R (10/75-on)	TE513R (10/75-on)		TR667			SX5243 Tie rod end bolt 12mm. BJ126 press in type with 41mm dia.
1975-77	929, 929L LA2, LA3 with 12mm ball pin tie rod		BJ247 screw in	SX1233 idler arm OEM2002K idler bush	TE512L	TE512L	TE513R	TE513R		TR667			SX5243 BJ247 screw in type with 41mm dia.
1977-78	929, 929L LA2, LA3 with 12mm ball pin tie rod		BJ249 press in	SX1233 idler arm OEM2002K idler bush	TE512L	TE512L	TE513R	TE513R		TR667			SX5243 BJ249 press in type with 43mm dia.
1977-8/81	929, 929L, LA4, LA5, HBSHE wagon with 12mm ball pin tie rod LA4MS Sedan & Wagon		BJ248 screw in	SX1233 idler arm OEM2002K idler bush	TE512L	TE512L	TE513R	TE513R		TR667			BJ248 screw in type with 43mm dia.
8/81-7/86	929, 929L HB - manual steer		RH-BJ1105 LH-BJ1106 (inc. arm)		TE678	TE678			RE899				
8/81-7/86	929, 929L HB - power steer		RH-BJ1105 LH-BJ1106 (inc. arm)		TE678	TE678			RE900				
7/86-91	929, 929L HC - V6 sedan & hardtop		RH-BJ4154 LH-BJ4155		TE678	TE678			RH-RE1490 LH-RE1491				

STEERING and SUSPENSION COMPONENTS

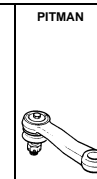
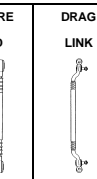
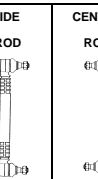
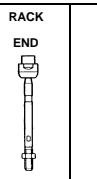
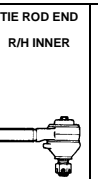
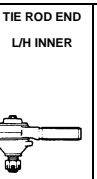
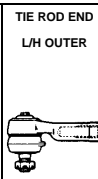
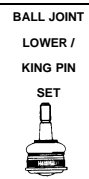

YEAR	MODEL	BALL JOINT UPPER	BALL JOINT LOWER / KING PIN SET	IDLER	TIE ROD END L/H OUTER	TIE ROD END R/H OUTER	TIE ROD END L/H INNER	TIE ROD END R/H INNER	RACK END	SIDE ROD	CENTRE ROD	DRAG LINK	PITMAN	NOTES/OTHER
------	-------	------------------	---------------------------------	-------	-----------------------	-----------------------	-----------------------	-----------------------	----------	----------	------------	-----------	--------	-------------

Mazda

	ASTINA - see 323 series													
	BONGO - see MAZDA Commercial - E series and F series													
	CAPELLA													
1970-73	Capella 1600 SNA, SN2A		BJ83 34mm dia	OEM2002K idler bush	TE479L	TE479L	TE480R	TE480R					SX5224	Tie rod ends with 10mm ball bolt & top of taper dia. - .425" SX5224 - 28 splines and 1 master spline
74-10/75	Capella 1600 SNA, SV2A with 10mm ball pin tie rod		BJ83 34mm dia	OEM2002K idler bush	TE510L	TE510L	TE482R	TE482R					SX5247	Tie rod ends with 10mm ball bolt & top of taper dia. - .502"
10/75-78	Capella 1600 SNA, CB1VS with 12mm ball pin tie rod		BJ249 43mm dia	OEM2002K idler bush	TE511L	TE511L	TE513R	TE513R					SX5247	Tie rod end bolt dia. - 12mm
1978-80	Capella 626 CB2NS, CB2VS, CB2MS		BJ149		TE514L	TE514L	TE568R	TE568R						
1980-83	Capella		BJ149		TE514L	TE514L	TE515R	TE515R						
	EUNOS													
1990-97	Eunos		BJ4550		TE3228	TE3228								
	Mazda 6													
2002-on	Mazda 6													
	MIATA													
1990-97	Miata		BJ4550		TE3228	TE3228								
1999-02	Miata		BJ4550		TE3228	TE3228								
	MX series													
11/89-97	MX5													
11/86-9/87	MX6 GC - manual steer		BJ306		TE678				RH-RE844R LH-RE844L					RE844R - overall length 275mm RE844L - overall length 295mm
11/86-9/87	MX6 GC - power steer		BJ306		TE678				RH-RE895R LH-RE896L					
11/86-10/91	MX6 GC GD 2.2lt Turbo - manual steer		BJ306		TE678	TE678			RE897					
11/86-10/91	MX6 GC GD 2.2lt Turbo - power steer		BJ306		TE678	TE678			RE898					

GD - 4 wheel steer

STEERING and SUSPENSION COMPONENTS

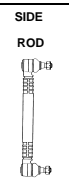
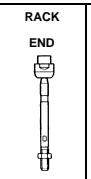
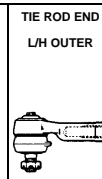
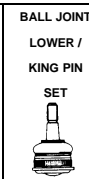

YEAR	MODEL	BALL JOINT UPPER	BALL JOINT LOWER / KING PIN SET	IDLER	TIE ROD END L/H OUTER	TIE ROD END R/H OUTER	TIE ROD END L/H INNER	TIE ROD END R/H INNER	RACK END	SIDE ROD	CENTRE ROD	DRAG LINK	PITMAN	NOTES/OTHER
------	-------	------------------	---------------------------------	-------	-----------------------	-----------------------	-----------------------	-----------------------	----------	----------	------------	-----------	--------	-------------

Mazda

														rear of vehicle RH-RE844R LH-RE844L
11/91-on	MX6 GE/EE - two wheel steering		RH-BJ4152 LH-BJ4153		TE970	TE970								RH-RE982 LH-RE983
	PERSONA													
2/90-on	Persona MA8P				TE678	TE678								
2/90-on	Persona MAEP				TE678	TE678								
	PROTEGE - see 323 series													
	ROTARY SERIES													
6/69-12/71	Rotary R100, RX2		BJ83		TE447L	TE447L	TE448R	TE448R						
1970-74	Rotary RX2 sedan & coupe		BJ83	OEM2002K idler bush	TE479L	TE479L	TE480R	TE480R					SX5224	Tie rod ends with 10mm ball bolt & top of taper dia. - .425" SX5224 - 28 splines and 1 master spline
1974-75	Rotary RX2 sedan & coupe CB1 - VS,2C,2S		BJ83	OEM2002K idler bush	TE510L	TE510L	TE482R	TE482R					SX5247	Tie rod ends with 10mm ball bolt & top of taper dia. - .502"
1975-77	Rotary RX2 sedan & coupe CB1 - VS, 2S		BJ249 press in	OEM2002K idler bush	TE511L	TE511L	TE513R	TE513R					SX5247	Tie rod end bolt dia. - 12mm
1972-6/75	Rotary RX3 sedan & coupe		BJ126 press in	SX1235	TE481L	TE481L	TE482R	TE482R					SX5229	Tie rod end bolt dia. - 10mm
7/75-77	Rotary RX3 sedan & coupe		BJ126 press in	SX1235	TE512L	TE512L	TE513R	TE513R					SX5229	Tie rod end bolt dia. - 12mm
10/72-10/75	Rotary RX4 sedan & coupe		BJ126 press in	SX1233	TE481L	TE481L	TE483R	TE483R					SX5242	
10/75-77	Rotary RX4 sedan & coupe		BJ126 press in	SX1233	TE512L	TE512L	TE513R	TE513R		TR667			SX5243	
1977-79	Rotary RX4 sedan & coupe		BJ249 press in	SX1233	TE512L	TE512L	TE513R	TE513R		TR667			SX5243	BJ249 press in type with 43mm dia.
1975-77	Rotary RX5 sedan & coupe		BJ247 screw in	SX1233	TE512L	TE512L	TE513R	TE513R					SX5243	BJ247 screw in type with 41mm dia.

STEERING and SUSPENSION COMPONENTS



YEAR	MODEL	BALL JOINT UPPER	BALL JOINT LOWER / KING PIN SET	IDLER	TIE ROD END L/H OUTER	TIE ROD END R/H OUTER	TIE ROD END L/H INNER	TIE ROD END R/H INNER	RACK END	SIDE ROD	CENTRE ROD	DRAG LINK	PITMAN	NOTES/OTHER
------	-------	------------------	---------------------------------	-------	-----------------------	-----------------------	-----------------------	-----------------------	----------	----------	------------	-----------	--------	-------------

1977-79	Rotary RX5 sedan & coupe		BJ248 screw in	SX1233	TE512L	TE512L	TE513R	TE513R					SX5243	BJ248 screw in type with 43mm dia.
3/78-85	Rotary RX7 SA22C series 2 door coupe		BJ149	OEM1003K idler bush	TE508L	TE508L	TE515R	TE515R					SX5243	
1986-88	Rotary RX7 Series 4 & 5 (FC1031 & FC1032)				TE3666R	TE3666R								
1993-on	Rotary RX7 FD3 series 2 door twin turbo coupe				TE840	TE840								

MAZDA - Commercial

B Series 2WD & 4WD														
1966-11/80	B1500, B1600, B1800 Utility BUD61,BNA61,BTA67,PE2N6,PE2V6	BJ99	BJ100	SX1149	TE192L	TE192L	TE191R	TE191R					TR591	
11/80-85	B1600, B1800, B2000, B2200 Utility PE2N7,PE2V7,UDX021,UDY021	BJ194	BJ195 14mm bolt thread	SX1150	TE590L	TE590L	TE589R	TE589R					SX5255	
1985-87	B2000, B2200 SGH Utility	BJ2003	BJ2004	SX4200	TE590L	TE590L	TE3609R	TE3609R					SX5200	SX5200 - 38 splines & 1 master - top spline diam. 24.7mm
1987-on	B2200 2WD Utility	BJ2003	BJ2004	SX4201	TE590L	TE590L	TE3613R	TE3613R		Some 2WD's use SX153 Pitman Arm - not SX5202			SX5202	SX5202 - 38 splines & 1 master - top spline diam. 24.7mm
1987-on	B2600 4WD Utility (Bravo)	BJ2003	BJ2005	SX4201	TE3667L	TE3667L	TE3613R	TE3613R		Please check splines prior to ordering.			SX5202	SX5202 - 38 splines & 1 master - top spline diam. 24.7mm
11/89-on	B2500, B2600 4WD Utility (UF66M) (Bravo)	BJ2003	BJ2005	SX4201	TE3667L	TE3667L	TE3613R	TE3613R					SX1531	SX1531 - 42 splines & 1 master - top spline diam. 26.5mm



	B2600	Front Spring Rear Pin	Front Spring Front Shackle L/H	Front Spring Front Shackle R/H	Rear Spring Front Pin PK272	Rear Spring Rear Shackle L/H SK272	Rear Spring Rear Shackle R/H SK272							Shackle & Pin Kits
--	-------	--------------------------	--------------------------------------	--------------------------------------	-----------------------------------	---	---	--	--	--	--	--	--	--------------------

STEERING and SUSPENSION COMPONENTS

M A Z D A - C O M M E R C I A L



YEAR	MODEL	BALL JOINT UPPER	BALL JOINT LOWER / KING PIN SET	IDLER	TIE ROD END L/H OUTER	TIE ROD END R/H OUTER	TIE ROD END L/H INNER	TIE ROD END R/H INNER	RACK END	SIDE ROD	CENTRE ROD	DRAG LINK	PITMAN	NOTES/OTHER
------	-------	------------------	---------------------------------	-------	-----------------------	-----------------------	-----------------------	-----------------------	----------	----------	------------	-----------	--------	-------------

	Bongo - see E series and F Series													
	E Series (Bongo - also see F series Bongo below)													
to 1976	E200, E2300, E2500				TE3616L	TE3616R								
1968-79	E1300 pickup truck BTA65,FA2T55,BPB65,FA2T65	BJ196	BJ197		TE443L	TE443L	TE445R	TE445R						
1971-77	E2000, E2500, E2700 EVB,EXB,EXC van & truck 2000 & 3000kg		KX267		TE605L	TE605R								King pin set - 1.105" x 6.700"
10/77-81	E2000, E2500, E3000 EVB,EXR,TA3		KX267		TE606L	TE606R								King pin set - 1.105" x 6.700"
1976-on	E3700		KX605											King pin set - 30mm x 175mm
1977-7/80	E1300, E1400, E1600	BJ198 4 bolt mount	BJ199 4 bolt mount	SX1300	TE592L	TE592L	TE593R	TE593R				TE593R front TE592L rear	SX5300	Ball joints have 4 mounting holes
7/80-4/83	E1400, E1600, E2200	BJ198 4 bolt mount	BJ199 4 bolt mount	SX1300	TE974	TE974	TE973	TE973						Ball joints have 4 mounting holes
1977-7/80	E1600 Bongo Panel Van (1000kg), E1600 Pick Up Truck (1000kg), BA2T8,BA2UB, SA2N8/9,BA2T8V,BA2N9V,BA2S8H, BA2S9H,BA2V9H	BJ198 4 bolt mount	BJ199 4 bolt mount		TE592L	TE593R								Ball joints have 4 mounting holes
8/80-4/83	E1600 Bongo Panel Van (1000kg), E1600 Pick Up Truck (1000kg), BA2T8,BA2UB, SA2N8/9,BA2T8V,BA2N9V,BA2S8H, BA2S9H,BA2V9H	BJ198 4 bolt mount	BJ199 4 bolt mount											Ball joints have 4 mounting holes
5/83-92	E1400, E1800, E2000, E2200 SRSS,SD Bongo Panel Van, SR89V,SREAV SRE9W,SRF9W,SR29V,SR2AV,SS48V, SS88W,SSF8V,SRE9V,SD89T,SD29T, SD2AT,SDEAT	BJ250 3 bolt mount	BJ251 3 bolt mount		TE679	TE679			RE854 male end					Ball joints have 3 mounting holes
10/84-on	E series SR,SS, 4WD Bongo Panel Van SREAM, SS88M,SS28M,SS28R,SS88R,SSE8R	BJ250 3 bolt mount							RE1410					Ball joints have 3 mounting holes
	F Series (Bongo - also see E series Bongo above)													

S A N T A - C O E F O R C I -

STEERING and SUSPENSION COMPONENTS



YEAR	MODEL	BALL JOINT UPPER	BALL JOINT LOWER / KING PIN SET	IDLER	TIE ROD END L/H OUTER	TIE ROD END R/H OUTER	TIE ROD END L/H INNER	TIE ROD END R/H INNER	RACK END	SIDE ROD	CENTRE ROD	DRAG LINK	PITMAN	NOTES/OTHER
------	-------	------------------	---------------------------------	-------	-----------------------	-----------------------	-----------------------	-----------------------	----------	----------	------------	-----------	--------	-------------

1966-68	Bongo Van F1000 FSA,FSAV,FSAH 800kg	RH-BJ95 LH-BJ96	RH-BJ97 LH-BJ98		TE192L male	TE192L male	TE191R male	TE191R male						Male type tie rod ends
1968-77	Bongo Van F1000 FPA,FPAH,FPAV 500kg	BJ196	BJ197		TE443L female	TE443L female	TE445R female	TE445R female					TE191R front TE192R rear	Female type tie rod ends
11/89-98	MPV MPV - 2WD		BJ3430 inc. arm		TE1581	TE1581			RE1580 (1989-95) RE1581 (1996-98)					2WD ONLY
1989-98	MPV - 4WD		BJ4162		TE1621	TE1621			RE1580 (1989-95) RE1581 (1996-98)					4WD ONLY
2000-02	MPV		BJ4164		TE4157	TE4157			RE4156					
	T Series													
1976-80	T2000,T2600,T3000,T3500,T4100,T4600 WE		KX605		TE606L	TE606R								King pin set 30mm x 175mm
1980-on	T2000,T2600,T3000,T3500,T4100,T4600 WE		KX605		TE606L	TE606R								King pin set 30mm x 175mm
	TITAN - see T Series above													
	TK Series ute & van													
5/68-71	1000, 1200 Ute - TK series	BJ196	BJ197		TE680	TE680							SX5232	
1971-76	1200, 1300 Ute - TK series Familia Truck	BJ196	BJ197		TE479L	TE479L	TE505R	TE505R					SX5233	Check tie rod end threads prior to ordering
1976-79	1600 Ute & Van - TK series Familia Truck	BJ196	BJ197		TE508L	TE508L	TE515R	TE515R						Check tie rod end threads prior to ordering
	TRAVELLER													
5/83-on	E1800, E2000	BJ250 3 bolt mount	BJ251 3 bolt mount		TE679	TE679			RE854 male end					Ball joints have 3 mounting holes
	TRIBUTE													
2001-02	Tribute		BJ4170		TE4170	TE4170			TE4170					

M A N D A T O R Y C O E L E C T I O N

STEERING and SUSPENSION COMPONENTS



YEAR	MODEL	BALL JOINT UPPER	BALL JOINT LOWER / KING PIN SET	IDLER	TIE ROD END L/H OUTER	TIE ROD END R/H OUTER	TIE ROD END L/H INNER	TIE ROD END R/H INNER	RACK END	SIDE ROD	CENTRE ROD	DRAG LINK	PITMAN	NOTES/OTHER
------	-------	------------------	---------------------------------	-------	-----------------------	-----------------------	-----------------------	-----------------------	----------	----------	------------	-----------	--------	-------------

M E R C E D E S

--	--	--	--	--	--	--	--	--	--	--	--	--	--	--

MERCEDES - Passenger Vehicles

	180/190 Series													
1955-66	180, 180A, B, C, DB, DC				TE402L 14x1.5mm thread	TE402L 14x1.5mm thread	TE402R 14x1.5mm thread	TE402R 14x1.5mm thread						Tie rod ends - 14 x 1.5mm threads
1955-66	190, 190B, C, D, DB, DC				TE402L 14x1.5mm thread	TE402L 14x1.5mm thread	TE402R 14x1.5mm thread	TE402R 14x1.5mm thread						Tie rod ends - 14 x 1.5mm threads
	W107 series													
1971-9/85	280, 350, 380, 450, 500SL, SLC	BJ187	BJ188		TE402L 14x1.5mm thread	TE402L 14x1.5mm thread	TE402R 14x1.5mm thread	TE402R 14x1.5mm thread				TR576 track rod		Tie rod ends - 14 x 1.5mm threads
9/85-8/89	280, 350, 380, 450, 500SL, SLC		BJ971		TE402L 14x1.5mm thread	TE402L 14x1.5mm thread	TE402R 14x1.5mm thread	TE402R 14x1.5mm thread						Tie rod ends - 14 x 1.5mm threads
	W108, W109 Series													
1965-72	250S, SE, 280S, SE, SEL, 35, 300SEL				TE402L 14x1.5mm thread	TE402L 14x1.5mm thread	TE402R 14x1.5mm thread	TE402R 14x1.5mm thread						Tie rod ends - 14 x 1.5mm threads
	W110, W111, Series													
1961-67	190, 200, 220, 230				TE402L 14x1.5mm thread	TE402L 14x1.5mm thread	TE402R 14x1.5mm thread	TE402R 14x1.5mm thread						Tie rod ends - 14 x 1.5mm threads
	C111 Series													
1961-78	250, 280SEC, 35				TE402L 14x1.5mm thread	TE402L 14x1.5mm thread	TE402R 14x1.5mm thread	TE402R 14x1.5mm thread						Tie rod ends - 14 x 1.5mm threads
	W113 Series													
1961-78	230, 250, 280SL				TE402L 14x1.5mm thread	TE402L 14x1.5mm thread	TE402R 14x1.5mm thread	TE402R 14x1.5mm thread						Tie rod ends - 14 x 1.5mm threads
	W114, W115 Series													
1968-77	200, 220, 230, 240D, 250, 280C, E, CE	BJ187 "late" taper 14;60 BJ1122 "early" taper 14;50 - not available	BJ188		TE402L 14x1.5mm thread	TE402L 14x1.5mm thread	TE402R 14x1.5mm thread	TE402R 14x1.5mm thread				TR577 track rod		Tie rod ends - 14 x 1.5mm threads BJ187 - 74mm centre to centre on longest side BJ1122 - 61mm hole
	W116 Series													
9/72-7/80	280S, SE, SEL, 350, 450SE, SEL	RH-BJ189 LH-BJ190	BJ191 ball joint		TE402L 14x1.5mm thread	TE582R 14x1.5mm thread	TE402R 14x1.5mm thread	TE583L 14x1.5mm thread				TR578 track rod		Tie rod ends - 14 x 1.5mm threads

STEERING and SUSPENSION COMPONENTS



YEAR	MODEL	BALL JOINT UPPER	BALL JOINT LOWER / KING PIN SET	IDLER	TIE ROD END L/H OUTER	TIE ROD END R/H OUTER	TIE ROD END L/H INNER	TIE ROD END R/H INNER	RACK END	SIDE ROD	CENTRE ROD	DRAG LINK	PITMAN	NOTES/OTHER
------	-------	------------------	---------------------------------	-------	-----------------------	-----------------------	-----------------------	-----------------------	----------	----------	------------	-----------	--------	-------------

		complete arms inc. bushes	only press in											
5/75-7/80	450SEL, 6.9lt		BJ191		TE584R 14x1.5mm thread	TE584R 14x1.5mm thread	TE402L 14x1.5mm thread	TE402L 14x1.5mm thread					TR579 track rod	Tie rod ends - 14 x 1.5mm threads
W123 Series														
1/76-10/84	230E, 240D, 250, 280E, CE, TE, 300D, TD	RH-BJ189 LH-BJ190 complete arms inc. bushes	BJ191 ball joint only		TE402L to 1977 M14x1.5 LHT	TE402L to 1977 M14x1.5 LHT	TE3380 to 1977 M14x1.5 RHT	TE3380 to 1977 M14x1.5 RHT					TR580 track rod	Tie rod ends - 14 x 1.5mm threads
					TE9071L 1977-8/1982 M16x1.5 LHT	TE9071L 1977-8/1982 M16x1.5 LHT	TE8071R 1977-8/1982 M16x1.5 RHT	TE8071R 1977-8/1982 M16x1.5 RHT						Tie rod ends - 16 x 1.5mm threads
					TE402L 8/1982-on M14x1.5 LHT	TE402L 8/1982-on M14x1.5 LHT	TE584R 8/1982-on M14x1.5 RHT	TE584R 8/1982-on M14x1.5 RHT						Tie rod ends - 14 x 1.5mm threads
W126 Series														
1/80-8/85	280, 280SE, 280SEL, 380, 380SE, 380SEL 500SE & 500SEL	RH-BJ193 LH-BJ192	BJ191		TE583L 14x1.5mm thread	TE402L 14x1.5mm thread	TE582R 14x1.5mm thread	TE402R 14x1.5mm thread					TR581 track rod	Tie rod ends - 14 x 1.5mm threads
W201 Series														
1982-on	190 all models		BJ186		TE574R	TE572L	TE575L	TE573R					TR571 track rod	
MERCEDES - Commercial														
	selected Tie Rod Ends etc. available													
MERCURY														
1979-94	Grand Marquis		10327											
M.G. - see LEYLAND														
MINI - see LEYLAND														
mitsubishi (VALIANT - see CHRYSLER)														
	CENTURA - see CHRYSLER													
	COLT													
1963-68	Colt 1000F, 1100				TE386R	TE386R	TE385L	TE385L						

M
i
t
s

STEERING and SUSPENSION COMPONENTS



YEAR	MODEL	BALL JOINT UPPER	BALL JOINT LOWER / KING PIN SET	IDLER	TIE ROD END L/H OUTER	TIE ROD END R/H OUTER	TIE ROD END L/H INNER	TIE ROD END R/H INNER	RACK END	SIDE ROD	CENTRE ROD	DRAG LINK	PITMAN	NOTES/OTHER
------	-------	------------------	---------------------------------	-------	-----------------------	-----------------------	-----------------------	-----------------------	----------	----------	------------	-----------	--------	-------------

1981-88

1980-3/84	Colt RA, RB GLX sedan & hatch up to chassis# PK29.....		RH-BJ170 LH-BJ169		TE552R 14x1.5mm thread	TE552R 14x1.5mm thread			RACK END FITMENT Colt series rack ends have been found to vary greatly. Please check measurements to determine fitment.					New Zealand - TR671 suits 83-87 power steer - Rack End
3/84-10/86	Colt RC sedan & hatch from chassis# PK29.....		RH-BJ170 LH-BJ169		TE729 (83-85) 12x1.5mm thread	TE729 (83-85) 12x1.5mm thread			RE885 - Female 300mm 14x1.5 TRE thread RE1855 - Female 300mm 14x1.5 TRE thread					New Zealand - TR671 suits 83-87 power steer - Rack End TE729 - overall length 85mm
10/86-8/88	Colt RD sedan & hatch		RH-BJ1169 LH-BJ1170		TE730 (86-on) 12x1.5mm thread	TE730 (86-on) 12x1.5mm thread			RE888 - Male 320mm 12x1.25 TRE thread RE886 - Male 295mm 12x1.25 TRE thread					TE730 - overall length 100mm
9/1988-on	Colt RE sedan & hatch		RH-BJ1169 LH-BJ1170		TE730 12x1.5mm thread	TE730 12x1.5mm thread			RE909 - Male 310mm 14x1.5 TRE thread					TE730 - overall length 100mm
CORDIA														
1983-85	Cordia AA, AB		BJ285		TE615R	TE615R			RE889 p/steer					
1985-89	Cordia AC		BJ285		TE615R	TE615R			RE890					
GALANT														
1970-74	Galant A51, GA, GB		BJ116	SX1202	TE463L	TE463L	TE464R	TE464R		TR400	TR401			TR401 - consists of TE463Lx1 / TE464Rx1 and one connecting tube
1974-76	Galant GA, GB, GC, GD		BJ122	SX1202	TE463L	TE463L	TE464R	TE464R		TR400	TR401			TR401 - consists of TE463Lx1 / TE464Rx1 and one connecting tube
1976-86	Galant GC, GD - except A163-8 models		BJ122	SX1147 (except GC 1977)	TE463L	TE463L	TE523R	TE522L		RH-TR666R LH-TR666L			SX1148	
1976-89	Galant GC, GD A163-8 models		BJ122	SX1147	TE463L	TE463L	TE523R	TE554L		RH-TR666R LH-TR666L			SX1148	
1987-93	Galant HG, HH		BJ285		TE3612R	TE3612R			RE908					
1993-98	Galant HJ	RH-BJ3775R LH-BJ3775L inc. arm	BJ3776 inc. arm		TE978	TE978			RE986					
1999-02	Galant				TE3779	TE3779			RE3779					
LANCER														
1974-81	Lancer LA, LB, LC		BJ122	SX1204	TE463L	TE463L	TE464R	TE464R		TR400			SX1206	

STEERING and SUSPENSION COMPONENTS

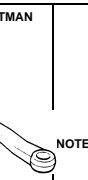
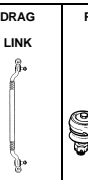
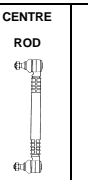
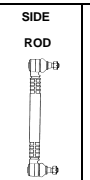
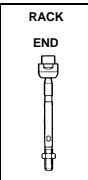
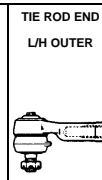
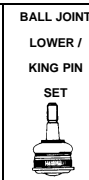

YEAR	MODEL	BALL JOINT UPPER	BALL JOINT LOWER / KING PIN SET	IDLER	TIE ROD END L/H OUTER	TIE ROD END R/H OUTER	TIE ROD END L/H INNER	TIE ROD END R/H INNER	RACK END	SIDE ROD	CENTRE ROD	DRAG LINK	PITMAN	NOTES/OTHER
------	-------	------------------	---------------------------------	-------	-----------------------	-----------------------	-----------------------	-----------------------	----------	----------	------------	-----------	--------	-------------

Mitsubishi

1988-9/92	Lancer CA, CB		RH-BJ1169** LH-BJ1170**		TE730	TE730			RE888 male end					** BJ1169/1170 - 2 bolt mount. Some vehicles this model range used BJ925 - press in. Check before ordering.
10/92-97	Lancer CC, CD				TE977	TE977			RE7969					
1997-on	Lancer CE				TE2076R	TE2076R			RE7969					
MAGNA (INCLUDES VERADA)														
1985-9/87	Magna TM - manual steer		BJ295		TE615R	TE615R			RE856					
1985-9/87	Magna TM - power steer		BJ295		TE615R	TE615R			RE889		Alternative Rack End: The following rack end has also been found to suit Magna models RE908			RE889 -317mm 14x1.5 Thread-breather hole
9/87-4/91	Magna TM, TN, TP, TR - manual steer		BJ295		TE615R	TE615R			RE890					RE890 - 14x1.5 Thread - NO breather hole
9/87-4/91	Magna TM, TN, TP, TR - power steer		BJ295		TE615R	TE615R			RE889					RE889 -317mm 14x1.5 Thread-breather hole
4/91-on	Magna, Verada TR, TS inc. wagon		BJ294 43mm diameter		TE615R	TE615R			RE1830 alternative is P191008 - but no breather hole		330mm 14x1.5 TRE Thread with breather hole Please check before ordering			RE1830 - 344mm 14x1.5 TRE Thread BJ294 - 43mm diameter
4/96-on	Magna TE, TF - TRW rack		BJ294 43mm diameter		TE9108R	TE9108R			P191043					P191043 - 1 thread length difference to P191008
2002-on	Magna TH				TE9108R	TE9108R								
MIRAGE														
1996-on	Mirage CE								RE7969					
NIMBUS														
1983-92	Nimbus UA, UB, UC - manual steer		BJ285 40mm diameter		TE615R	TE615R			RE856					BJ285 - 40mm diameter
1983-92	Nimbus UA, UB, UC - power steer		BJ285 40mm diameter		TE615R	TE615R			RE889					BJ285 - 40mm diameter
PROTON - see PROTON														
SCORPION														
1978-81	Scorpion GE, GH		BJ122	SX1147	TE463L	TE463L	TE523R	TE522L						SX1148
1980-85	Scorpion GJ, GK, GL		BJ172	SX1147	TE463L	TE463L	TE523R	TE554L						SX1148

STEERING and SUSPENSION COMPONENTS

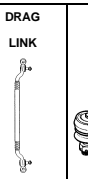
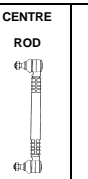
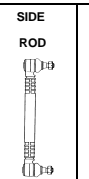
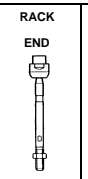
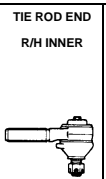
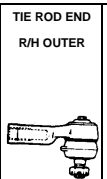
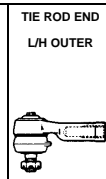
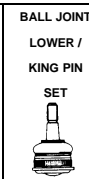

YEAR	MODEL	BALL JOINT UPPER	BALL JOINT LOWER / KING PIN SET	IDLER	TIE ROD END L/H OUTER	TIE ROD END R/H OUTER	TIE ROD END L/H INNER	TIE ROD END R/H INNER	RACK END	SIDE ROD	CENTRE ROD	DRAG LINK	PITMAN	NOTES/OTHER
------	-------	------------------	---------------------------------	-------	-----------------------	-----------------------	-----------------------	-----------------------	----------	----------	------------	-----------	--------	-------------

SIGMA														
1977-81	Sigma GE, GH		BJ122	SX1147	TE463L	TE463L	TE523R	TE522L						SX1148
1980-87	Sigma GJ, GK, GL, GN		BJ172	SX1147	TE463L	TE463L	TE523R	TE554L						SX1148
STARION														
1982-87	Starion JA, JB, JD		BJ172		TE463L	TE463L	TE523R	TE554L						Please check tie rod end dimensions b4 ordering
VALIANT - see CHRYSLER														
VERADA - see MAGNA														

mitsubishi - Commercial

CANTER														
1975-79	Canter T210, T217 series		KX258 9mm bearing		TE561R RH thread	TE561L LH thread								King pin set - 28 x 179.4mm Tie Rod Ends - check thread prior to ordering
1979-82	Canter FC2, FE2 series		KX258 9mm bearing		TE561R RH thread	TE561L LH thread								KX258 bush length = 49mm Tie Rod Ends - check thread prior to ordering
1983-84	Canter FC2, FE2 series		KX259 9mm bearing		TE561R RH thread	TE561L LH thread								KX259 bush length = 44mm Tie Rod Ends - check thread prior to ordering
1983-on	Canter FE211 - 9mm bearing		KX526 9mm bearing		TE561R RH thread	TE561L LH thread								King pin set - 28 x 180mm Tie Rod Ends - check thread prior to ordering
1978-on	Canter FE211 - 16mm bearing to chassis no. C502437/E5138/D530130		KX534 16mm bearing		TE561R RH thread	TE561L LH thread								King pin set - 28 x 180mm Tie Rod Ends - check thread prior to ordering
1976-on	Canter FE444C		KX534 16mm bearing		TE561R RH thread	TE561L LH thread								King pin set - 28 x 180mm Tie Rod Ends - check thread prior to ordering
CHALLENGER														
1996-97	Challenger K96W, K97W			SX7800										
1998-on	Challenger K99W		BJ810		TE976R	TE976R	TE7722	TE7722						
FUSO														
1965-on	Fuso T620, T622, T653, FK115 4ton		KX276		TE628L	TE628R								King pin set - 35 x 194mm

STEERING and SUSPENSION COMPONENTS

mitsubishi - Commercial



YEAR	MODEL	BALL JOINT UPPER	BALL JOINT LOWER / KING PIN SET	IDLER	TIE ROD END L/H OUTER	TIE ROD END R/H OUTER	TIE ROD END L/H INNER	TIE ROD END R/H INNER	RACK END	SIDE ROD	CENTRE ROD	DRAG LINK	PITMAN	NOTES/OTHER
------	-------	------------------	---------------------------------	-------	-----------------------	-----------------------	-----------------------	-----------------------	----------	----------	------------	-----------	--------	-------------

1977-84	Fuso FM215, FM515, FK455, FK457 6ton		KX277											King pin set - 45 x 217mm	
	Fuso FM515		KX531												
	Fuso FM515, FM555, FK457		KX538												
1980-on	Fuso FM555FS, JS, MS/FM557		KX521/1											When is a car not a car?	
1983-on	FK1, FK102, FK115 4.25ton		KX529											When it turns into a driveway!!!	
	FK415FR, KR, WR 3.5-4.25ton		KX530												
	FP415, FP418, FS428, FV415, FV458		KX532												
1986-on	FV418		KX539												
1990-on	FK330, FK415, FK417		KX540												
1988-on	FM516				TE7741L	TE7741R									
	L200 (2WD)														
1978-8/80	L200 D50, MA	BJ212 press in	BJ216	SX1157	TE463L male end	TE463L male end	TE523R male end	TE588L female end					SX1148	Upper inner pivot kit - SX7251A	
9/80-86	L200 MB, MC, MD 2WD	BJ214 press in	BJ218	SX1158	TE463L male end	TE463L male end	TE523R male end	TE588L female end					SX5228	SX5228 - 42 splines (with alignment groove) Upper inner pivot kit - SX7251A	
1986-91	L200 MB, MC, MD 2WD	BJ7155	BJ218	SX4251	TE463L	TE463L	TE523R	TE588L					SX5228	SX5228 - 42 splines (with alignment groove) Upper inner pivot kit - SX7251A	
1991-96	L200 2WD												SX3715		
	L200 (4WD)														
9/80-86	L200 MB, MC, MD 4WD	BJ214	BJ215	SX1159 <i>picture following</i>	TE617R	TE617R	TE618R	TE618R					SX1213	SX1213 - 26-27mm tapered spline with 42 splines Upper inner pivot kit - SX7251A	
1986-91	L200 MB, MC, MD 4WD	BJ7155	BJ215	SX1159 <i>picture following</i>	TE617R	TE617R	TE618R	TE618R					SX7227	SX7227 - 30-30.5mm tapered spline with 40 splines Upper inner pivot kit - SX7251A	
	L200 Pre 6/91	Front Spring Rear Pin	Front Spring Front Shackle L/H	Front Spring Front Shackle R/H	Rear Spring Front Pin PK273	Rear Spring Rear Shackle L/H SK273	Rear Spring Rear Shackle R/H SK273								Shackle & Pin Kits
	L300 (2WD)														
1968-76	L300 express T100,120,121	BJ245	BJ246					TE551R LH thread	TE551R LH thread						
1976-79	L300 express T100,120,121	BJ212						TE551R LH thread	TE551R LH thread						

Upper Inner Pivot Kit
Part No. SX7251A
to suit Mitsubishi L200 & Pajero
2WD & 4WD 1978-91

SX7251A - two kits required per vehicle
One Pin & Two bushes per kit

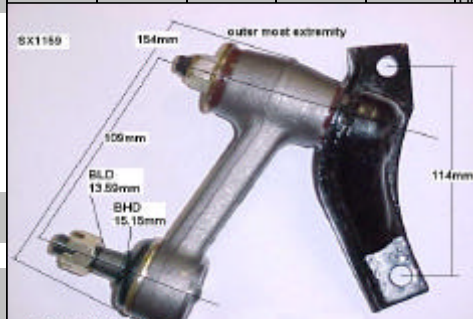

STEERING and SUSPENSION COMPONENTS



YEAR	MODEL	BALL JOINT UPPER	BALL JOINT LOWER / KING PIN SET	IDLER	TIE ROD END L/H OUTER	TIE ROD END R/H OUTER	TIE ROD END L/H INNER	TIE ROD END R/H INNER	RACK END	SIDE ROD	CENTRE ROD	DRAG LINK	PITMAN	NOTES/OTHER
------	-------	------------------	---------------------------------	-------	-----------------------	-----------------------	-----------------------	-----------------------	----------	----------	------------	-----------	--------	-------------

1980-82	L300 SA3,SB3 series, express van, wagon 3 & 8 seater 1000kg	BJ212	BJ216				TE551R LH thread	TE551R LH thread						
1980-10/82	L300 SA, SB 2WD	BJ212	BJ216	SX1161	TE552R	TE552R	TE551R LH thread	TE551R LH thread					DL403	SX1218 SX1218 - suits bell crank application Bell crank pivot - SX6245 Bell crank pivot bush - OEM6245
11/82-83	L300 SA, SB 2WD	BJ212	BJ216	SX1161	TE615R	TE615R	TE616L	TE616L					DL403	SX1218 SX1218 - suits bell crank application Bell crank pivot - SX6245 Bell crank pivot bush - OEM6245
10/83-6/86	L300 SC, SD, SE 2WD	BJ214	BJ217	SX1162	TE615R	TE615R	TE616L	TE616L					DL404	SX1214 SX1214 - suits bell crank application Bell crank pivot - SX6245 Bell crank pivot bush - OEM6245
6/86-92	L300 SF, SG 2WD - manual steer	BJ275	BJ276		TE715 female end	TE715 female end			RE909					
6/86-92	L300 SF, SG 2WD - power steer	BJ275	BJ276		TE715 female end	TE715 female end			RE890					
1990-on	L300 SH, SJ 2WD	BJ275	BJ276		TE715 female end	TE715 female end			RE890					MARIO!!
	 L300 Pre 1993 IFS / Leaf Spring	Front Spring Rear Pin	Front Spring Front Shackle L/H	Front Spring Front Shackle R/H	Rear Spring Front Pin PK273	Rear Spring Rear Shackle L/H SK273	Rear Spring Rear Shackle R/H SK273							Shackle & Pin Kits
	L300 (4WD)													
10/83-6/86	L300 SC, SD, SE 4WD	BJ214	BJ215	SX1163	TE617R	TE617R	TE618R	TE618R					TR779 (10/82-90)	SX5781 to Bell Crank 1985 bell crank - SX7550 (see diagram below) Upper inner pivot kit - SX7251A
6/86-on	L300 SF, SG, SH, SJ 4WD - manual steer	BJ275	RH-BJ277 LH-BJ278	SX1163	TE715 female end	TE715 female end			RE910				TR779 (10/82-90)	SX5781 to Bell Crank
6/86-on	L300 SF, SG, SH, SJ 4WD - power steer	BJ275	RH-BJ277 LH-BJ278	SX1163	TE715 female end	TE715 female end			RE911				TR779 (10/82-90)	SX5781 to Bell Crank

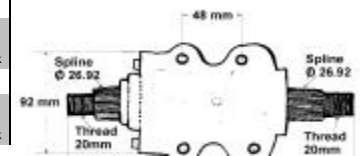

STEERING and SUSPENSION COMPONENTS



YEAR	MODEL	BALL JOINT UPPER	BALL JOINT LOWER / KING PIN SET	IDLER	TIE ROD END L/H OUTER	TIE ROD END R/H OUTER	TIE ROD END L/H INNER	TIE ROD END R/H INNER	RACK END	SIDE ROD	CENTRE ROD	DRAG LINK	PITMAN	NOTES/OTHER
------	-------	------------------	---------------------------------	-------	-----------------------	-----------------------	-----------------------	-----------------------	----------	----------	------------	-----------	--------	-------------

P

	PAJERO (MONTERO)														
4/82-10/84	Pajero NA 4WD manual steer to chassis# FL042VDY-01374 petrol and up to FL042VDY4-01375 diesel	BJ214	BJ215	SX4252	TE617R	TE617R	TE618R	TE618R					SX3273	SX5244	SX5244 - 26-27mm tapered spline with 42 splines Upper inner pivot kit - SX7251A
7/83-9/89	Pajero NA 4WD manual steer from chassis# FL042VDY-01374 petrol and FL043VDY4-01375 diesel on	BJ214	BJ215	SX4252	TE617R	TE617R	TE618R	TE618R					SX3273	SX5245	SX5245 - 30-30.5mm tapered spline with 40 splines Upper inner pivot kit - SX7251A
7/83-9/89	Pajero NA power steer NB, NC, ND, NE, NF, NG 4WD from chassis# FL042VDY-01374 petrol and FL043VDY4-01375 diesel on	BJ214	BJ215	SX4252	TE617R	TE617R	TE618R (O.E.M. Products brand) or TE620R# (555 Japanese Brand)	TE618R or TE620R# (555 Japanese Brand)					SX3273	SX5245	SX5245 - 30-30.5mm tapered spline with 40 splines Upper inner pivot kit - SX7251A
9/89-5/91	Pajero NG 4WD	BJ214	BJ215	SX4252	TE617R	TE617R	TE618R (O.E.M. Products brand) or TE620R# (555 Japanese Brand)	TE618R or TE620R# (555 Japanese Brand)					SX3273	SX7710	SX7710 - 32-33mm tapered spline with 32 splines
5/91-10/96	Pajero NH, NJ 4WD - manual steer	BJ820 3 bolt mount <i>picture following</i>	RH-BJ823 LH-BJ822 4 bolt mount	SX4280 (SX1042)	TE976R	TE976R	TE7722	TE7722						SX5248	<i>NOTE: SX7710 / SX5249 - different angles from spline to Ball Joint</i>
5/91-9/97	Pajero NH, NJ, NK 4WD - power steer	BJ820 3 bolt mount <i>picture following</i>	RH-BJ823 LH-BJ822 4 bolt mount	SX4280 (SX1042)	TE976R	TE976R	TE7722	TE7722						SX5248	SX5248 - 32mm dia. spline with 32 splines
9/97-99	Pajero NL 4WD (K96W)	BJ820 3 bolt mount <i>picture following</i>	RH-BJ823 LH-BJ822 4 bolt mount	SX4280 (SX1042) idler arm	TE976R	TE976R	TE7722	TE7722						SX5248	
5/00-2002	Pajero NM 4WD	BJ6792 (front) BJ8130 (rear)	BJ6799		TE3781	TE3781									

M-979-5-1-COE-0

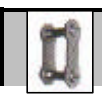

Pajero Pre 1993 IFS / Leaf Spring	Front Spring Rear Pin	Front Spring Front Shackle L/H	Front Spring Front Shackle R/H	Rear Spring Front Pin	Rear Spring Rear Shackle L/H	Rear Spring Rear Shackle R/H
-----------------------------------	--------------------------	--------------------------------------	--------------------------------------	--------------------------	------------------------------------	------------------------------------



Shackle & Pin Kits



YEAR	MODEL	BALL JOINT UPPER	BALL JOINT LOWER / KING PIN SET	IDLER	TIE ROD END L/H OUTER	TIE ROD END R/H OUTER	TIE ROD END L/H INNER	TIE ROD END R/H INNER	RACK END	SIDE ROD	CENTRE ROD	DRAG LINK	PITMAN	NOTES/OTHER
------	-------	------------------	---------------------------------	-------	-----------------------	-----------------------	-----------------------	-----------------------	----------	----------	------------	-----------	--------	-------------

C

	STARWAGON (2WD)				PK273	SK273	SK273							
1986-90	Starwagon SF, SG 2WD	BJ275	BJ276 press in		TE715	TE715	TE616L	TE616L						
1990-on	Starwagon SH, WA 2WD	BJ275	NOT BJ276! big 4 bolt in		TE715	TE715								
	STARWAGON (4WD)													
1986-on	Starwagon SF, SG, SH, WA 4WD manual steer	BJ275	RH-BJ277 LH-BJ278		TE715	TE715			RE910					
1986-on	Starwagon SF, SG, SH, WA 4WD power steer	BJ275	RH-BJ277 LH-BJ278		TE715	TE715			RE911					

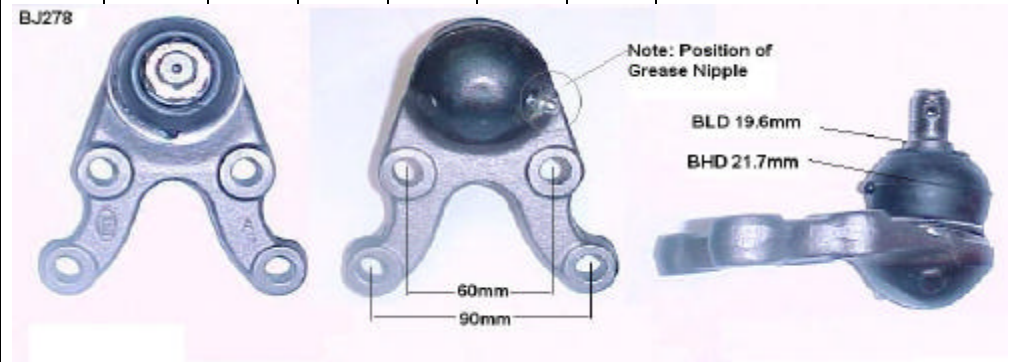
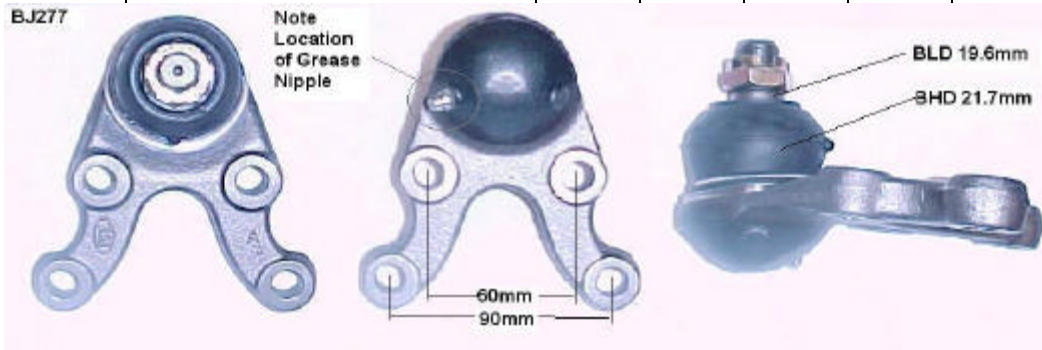

M
i
t
s
b
i
s
h

	TRITON (2WD)													
1986-92	Triton ME, MF, MG, MH 2WD	BJ214 press in	BJ218	SX4251	TE463L	TE463L	TE523R	TE588L					SX1255 slight bend in arm	some models use SX5245 - check spline SX1255 - 42 splines with alignment groove (no master) SX5245 - 40 splines (straight arm)
1992-96	Triton MJ 2WD excluding V6	RH-BJ821 LH-BJ811	BJ810	SX4251	TE463L	TE463L	TE523R	TE588L					SX1255 slight bend in arm	some models use SX5245 - check spline SX1255 - 42 splines with alignment groove (no master) SX5245 - 40 splines (straight arm)
1992-96	Triton MJ 2WD - V6			SX1159										
1996-on	Triton MK 2WD - excluding V6			SX2410										

STEERING and SUSPENSION COMPONENTS



YEAR	MODEL	BALL JOINT UPPER	BALL JOINT LOWER / KING PIN SET	IDLER	TIE ROD END L/H OUTER	TIE ROD END R/H OUTER	TIE ROD END L/H INNER	TIE ROD END R/H INNER	RACK END	SIDE ROD	CENTRE ROD	DRAG LINK	PITMAN	NOTES/OTHER
------	-------	------------------	---------------------------------	-------	-----------------------	-----------------------	-----------------------	-----------------------	----------	----------	------------	-----------	--------	-------------

CORONA

1996-on	Triton MK 2WD - V6		BJ2427	SX6273										
TRITON (4WD)														
1986-3/91	Triton ME, MF, MG, MH 4WD - petrol & diesel	BJ214	BJ215	SX1159	TE617R	TE617R	TE618R	TE618R						SX7227
4/91-96	Triton MJ 4WD	BJ7155	BJ215	SX1159	TE617R	TE617R	TE6274	TE6274						SX7227
10/96-98	Triton MK 4WD (K74T)	BJ820	RH-BJ823 LH-BJ822	SX6273	TE976R	TE976R	TE6274	TE6274			TR3560 Relay Rod			SX5248
1998-on	Triton MK 4WD		BJ810		TE976R	TE976R	TE7722	TE7722						

	Triton 4WD 6/91-on IFS / Leaf Spring	Front Spring Rear Pin	Front Spring Front Shackle L/H	Front Spring Front Shackle R/H	Rear Spring Front Pin PK273	Rear Spring Rear Shackle L/H SK273	Rear Spring Rear Shackle R/H SK273								Shackle & Pin Kits
--	--	--------------------------	--------------------------------------	--------------------------------------	-----------------------------------	---	---	--	--	--	--	--	--	--	--------------------

MORRIS - see LEYLAND

NISSAN inc. DATSUN

1000															
1967-70	Datsun 1000 B10,RB10,VB10,B20 outer's have 12mm thread	BJ89	BJ91		TE187L 12mm thread	TE187R 12mm thread	TE183R	TE183L							Outer tie rod ends - 12mm thread
1967-70	Datsun 1000 B10,RB10,VB10,B20 outer's have 14mm thread	BJ89	BJ91		TE437L 14mm thread	TE437R 14mm thread	TE183R	TE183L							Outer tie rod ends - 14mm thread
1200															
1969-74	Dastun 1200 B110, B120,KB110,VB110		BJ92	SX1135	TE440L 77mm long straight	TE440R	TE519R 107mm long with relief bend	TE519L		RH-TE519L LH-TE519R	TR409				BJ92 - mounting holes 41mm apart centre to centre TE519R = LH thread : TE519L = RH thread
120Y															
1973-76	Datsun 120Y B120,B121,B210, B211		BJ92	SX1136	TE518L 77mm long with bend	TE518R	TE519R 107mm long with relief bend	TE519L		RH-TE519L LH-TE519R	TR412				BJ92 - mounting holes 41mm apart centre to centre TE519R = LH thread : TE519L = RH thread

CORONA

STEERING and SUSPENSION COMPONENTS

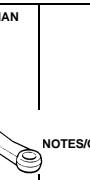
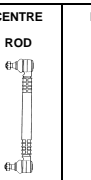
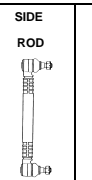
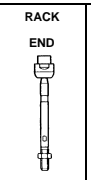
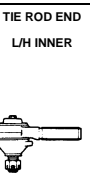
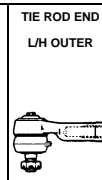
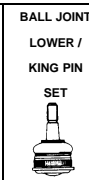

YEAR	MODEL	BALL JOINT UPPER	BALL JOINT LOWER / KING PIN SET	IDLER	TIE ROD END L/H OUTER	TIE ROD END R/H OUTER	TIE ROD END L/H INNER	TIE ROD END R/H INNER	RACK END	SIDE ROD	CENTRE ROD	DRAG LINK	PITMAN	NOTES/OTHER
------	-------	------------------	---------------------------------	-------	-----------------------	-----------------------	-----------------------	-----------------------	----------	----------	------------	-----------	--------	-------------

an

1975-77	Datsun 120Y B120,B121,B210, B211		BJ176	SX1136	TE518L 77mm long with bend	TE518R	TE519R 107mm long with relief bend	TE519L		RH-TE519L LH-TE519R	TR412			BJ176 - mounting holes 51mm apart centre to centre TE519R = LH thread : TE519L = RH thread
1976-79	Datsun 120Y B310		BJ176	SX1136	TE518L 77mm long with bend	TE518R	TE519R 107mm long with relief bend	TE519L		RH-TE519L LH-TE519R	TR412			BJ176 - mounting holes 51mm apart centre to centre TE519R = LH thread : TE519L = RH thread
1300/1400/1600														
67-9/68	Datsun 1300/1400/1600 sedan		BJ146 12mm thread	SX1121										BJ146 - 12mm ball bolt thread
10/68-1972	Datsun 1300/1400/1600 sedan & wagon P510 series		BJ85 14mm thread	SX1121	TE437L	TE437R	TE438R	TE438L		RH-TR413R LH-TR413L	TR415			BJ85 - 14mm ball bolt thread TR413R - consists of TE437R / TE438L / CR655 Connecting Rod - CR655 (14x1.5) 166mm o/all lgth
1973-77	Datsun 140J,140Y,160B, Violet		BJ85	SX1121	TE437L	TE437R	TE438R	TE438L						BJ85 - 14mm ball bolt thread
180B														
1972-10/77	Datsun 180B sedan, wagon & SSS coupe		BJ85	SX1121	TE437L	TE437R	TE438R	TE438L		RH-TR413R LH-TR414L	TR415			BJ85 - 14mm ball bolt thread TR413R - consists of TE437R / TE438L / CR655 Connecting Rod - CR655 (14x1.5) 166mm o/all lgth
180SX - see GAZELLE														
200B														
1975-79	Datsun 200B SX,S10,S11			SX1121 3 Bolt Mount	TE437L	TE437R	TE438R	TE438L						
10/77-81	Datsun 200B sedan, wagon & SSS coupe		BJ151 **	SX4220 2 Bolt Mount	TE520L	TE520L	TE521R	TE521R		TR656	TR416			TR656 - consists of TE520L / TE521R / AS656 Adjusting Sleeve - AS656 (18x1.5) 100mm o/all lgth ** BJ151 - if recessed body required use BJ151# (555)
200SX														
	200SX - S14								RE844L					
240C,260C,280C,300C														
1971-74	Datsun 240C - H230 series			SX4221	TE432R	TE432R	TE546L	TE546L						
1975-6/77	Datsun 260C - H330 series		RH-BJ206 LH-BJ207	SX260C	TE432R	TE432R	TE546L	TE546L			TR408			
7/77-6/79	Datsun 280C - H330 series	BJ205	RH-BJ206 LH-BJ207	SX260C	TE432R	TE432R	TE546L	TE546L			TR408			
6/79-1984	Datsun 280C - P430 series	BJ205	RH-BJ2027	SX4253	TE3655L	TE3655L	TE3657R	TE3656R		RH-TR439R	TR410			

STEERING and SUSPENSION COMPONENTS



YEAR	MODEL	BALL JOINT UPPER	BALL JOINT LOWER / KING PIN SET	IDLER	TIE ROD END L/H OUTER	TIE ROD END R/H OUTER	TIE ROD END L/H INNER	TIE ROD END R/H INNER	RACK END	SIDE ROD	CENTRE ROD	DRAG LINK	PITMAN	NOTES/OTHER
------	-------	------------------	---------------------------------	-------	-----------------------	-----------------------	-----------------------	-----------------------	----------	----------	------------	-----------	--------	-------------

Datsun

			LH-BJ2028							LH-TR439L				
1984-87	Datsun 300C - Y30 series VG2#, VG3#, LD28, RD28		BJ554	SX1205 p/steer	TE234R	TE234R	TE238R	TE239L		RH-TR443 LH-TR444	TR428			
1984-87	Datsun 300C - Y30 series CA20, L20P		BJ554	SX1205 p/steer	TE234R	TE234R	TE239L	TE239L		TR443	TR428			
	240K													
1973-79	Datsun 240K - C110 series		BJ151	SX4221	TE520L	TE520L	TE521R	TE521R		TR656	TR417			TR656 - consists of TE520L / TE521R / AS656 Adjusting Sleeve - AS656 (18x1.5) 100mm o/all lgth
	240Z, 260Z, 280ZX, 300ZX													
to 6/1970	Datsun 240Z		BJ146 12mm thread											12mm ball pin ball joint
7/70-78	Datsun 240Z,260Z,260Z Sports Coupe		BJ85 14mm thread		TE860L	TE860R								14mm ball pin ball joint
8/78-10/81	Datsun 280ZX coupe - manual rack & pinion steering		BJ151		TE3644	TE3644			RE754					
8/78-10/81	Datsun 280ZX coupe - with power recirc. ball steering		BJ151	SX4254	TE520L	TE520L	TE3644	TE3644						
10/81-10/83	Datsun 280ZX with manual rack & pinion steering		BJ151						RE859 male end					
10/81-10/83	Datsun 280ZX with power rack & pinion steering		BJ151		TE3644	TE3644			RE859 male end					
9/83-1/86	300ZX with 3.0lt V6 - Z31#		BJ273		TE667R	TE667R			RE859 male end					
1/86-1990	300ZX inc. turbo - Z31#		BJ273		TE666R	TE666R			RE859 male end					
	300ZX inc. turbo - Z32#								RE858					RE858 - Rear Rack End (no boot supplied)
	BLUEBIRD													
1963-68	Bluebird P410,P411	BJ58	RH-BJ59 LH-BJ60	SX1108A	TE187L	TE187R	TE187R	TE187L						
67-9/68	Bluebird 510 series (1300,1400,1600)		BJ146 12mm thread	SX1121	TE435L	TE435R								BJ146 - 12mm ball bolt thread

STEERING and SUSPENSION COMPONENTS



YEAR	MODEL	BALL JOINT UPPER	BALL JOINT LOWER / KING PIN SET	IDLER	TIE ROD END L/H OUTER	TIE ROD END R/H OUTER	TIE ROD END L/H INNER	TIE ROD END R/H INNER	RACK END	SIDE ROD	CENTRE ROD	DRAG LINK	PITMAN	NOTES/OTHER
------	-------	------------------	---------------------------------	-------	-----------------------	-----------------------	-----------------------	-----------------------	----------	----------	------------	-----------	--------	-------------

10/68-72	Bluebird 510 series (1300,1400,1600)		BJ85 14mm thread	SX1121	TE437L	TE437R	TE438R	TE438L		RH-TR413R LH-TR414L	TR415			BJ85 - 14mm ball bolt thread TR413R - consists of TE437R / TE438L / CR655 Connecting Rod - CR655 (14x1.5) 166mm o/all lgth
8/71-76	Bluebird 610 series exc. G610		BJ85	SX1121	TE437L	TE437R	TE438R	TE438L		RH-TR413R LH-TR414L	TR415			TR413R - consists of TE437R / TE438L / CR655 Connecting Rod - CR655 (14x1.5) 166mm o/all lgth
1980-86	Bluebird 910 with NO RACK		BJ178		TE520L	TE520L	TE521R	TE521R						
1980-86	Bluebird 910 with Japanese steering rack		BJ178		TE560L	TE560R			RE859 male end fine thread					Japanese rack
1980-86	Bluebird 910 with TRW steering rack		BJ178		TE560L	TE560R			P191006 166mm long male or P189014 135mm long female					TRW rack
1980-86	Bluebird 910 with captive rack end		BJ178		TE560L	TE560R			P191002 coarse thread					Captive Rack End
10/93-on	Bluebird U13 series		BJ4016		TE981	TE981			RE955					
	EXA - see PULSAR													
	GAZELLE / SYLVIA / 180SX													
10/75-79	Gazelle S10, S11		BJ85	SX1121	TE437L	TE437R	TE438R	TE438L		RH-TR413R LH-TR414L				
3/79-4/81	Gazelle S110, S218		BJ163		TE518L	TE518R	TE519L	TE519R						
5/81-83	Gazelle S110, S218		BJ4492											
8/83-88	Gazelle S12# series		BJ178		TE560L	TE560R			RE859 male end					
5/88-91	Gazelle S13# series				TE713	TE713			RE857					
1/91-93	Gazelle S13# series				TE713	TE713								
	MAXIMA													

STEERING and SUSPENSION COMPONENTS



YEAR	MODEL	BALL JOINT UPPER	BALL JOINT LOWER / KING PIN SET	IDLER	TIE ROD END L/H OUTER	TIE ROD END R/H OUTER	TIE ROD END L/H INNER	TIE ROD END R/H INNER	RACK END	SIDE ROD	CENTRE ROD	DRAG LINK	PITMAN	NOTES/OTHER
10/88-91	Maxima J30 series		BJ555		TE4761R	TE4761R			RE4760					
8/91-on	Maxima J30 series		BJ555		TE4761R	TE4761R			RE2171					
	NX													
10/91-6/95	NX Coupe													
	PINTARA													
8/85-12/91	Pintara R31 - imported steering rack		BJ274		TE714P 235mm long	TE714P 235mm long			RE859 150mm male					TE714P - 235mm Long
6/85-on	Pintara R31 - TRW steering rack		BJ274		TE714 221mm long	TE714 221mm long			P191006 (RE907) 165mm male					TE714 - 221mm Long
8/89-7/92	Pintara U12 front wheel drive - imported steering rack		BJ555		TE2225 12mm thread	TE2225 12mm thread			RE857 12mm thread					12mm
8/89-7/92	Pintara U12 front wheel drive - TRW rack		BJ286		TE739 80mm long 14mm thread	TE739 80mm long 14mm thread			P191013 14mm thread 310mm male					14mm
	PRAIRIE													
8/82-86	Prairie M10		BJ242		TE713 100mm long	TE713 100mm long			RE857 12mm thread					
	PULSAR (inc. EXA)													
5/78-4/82	Pulsar N10,N11 Note: some late N10 models are fitted with TE3600R		BJ181 threaded		TE563R 88mm long	TE563R 88mm long			RE871	TR4370				BJ181 - threaded bolt mount holes
4/82-5/86	Pulsar N12 - imported steering rack		BJ242 no thread		TE664 90mm long	TE664 90mm long			RE857 12mm thread	TR654				BJ242 - no thread in bolt mount holes TR4480 - consists of TE664 / RE857
4/82-5/86	Pulsar N12 - TRW steering rack		BJ242 no thread		TE664 90mm long	TE664 90mm long			P191001 12mm dia. shaft					BJ242 - no thread in bolt mount holes
5/86-10/91	Pulsar N13 & EXA KN13 power steer		BJ261 push in		TE713 100mm long	TE713 100mm long			RE857 12mm thread	TR684 p/steer or TR665 m/steer				TE713 - 12mm x 101mm BJ261 - push in style ball joint
4/88-on	Pulsar N13 power/manual steer - TRW rack		BJ261		TE739	TE739			P191011					TE739 - 14mm x 80mm

STEERING and SUSPENSION COMPONENTS

2000-2009



YEAR	MODEL	BALL JOINT UPPER	BALL JOINT LOWER / KING PIN SET	IDLER	TIE ROD END L/H OUTER	TIE ROD END R/H OUTER	TIE ROD END L/H INNER	TIE ROD END R/H INNER	RACK END	SIDE ROD	CENTRE ROD	DRAG LINK	PITMAN	NOTES/OTHER
------	-------	------------------	---------------------------------	-------	-----------------------	-----------------------	-----------------------	-----------------------	----------	----------	------------	-----------	--------	-------------

			push in		80mm long	80mm long			14mm dia. shaft					BJ261 - push in style ball joint
10/91-5/96	Pulsar N14 - imported rack		BJ4190 (1990-92) BJ4195 (1992-on) ball joint only RH-BJ4156 LH-BJ4157 inc. arm		TE926 95mm long	TE926 95mm long			RE988 290mm male	TR4740				BJ4156/4157 - complete arms ** these are NOT 'Y' shaped arms *** BJ4190 & BJ4195 - check prior to ordering (approx. only change-over year range listed)
9/91-10/92	Pulsar N14 - TRW rack		BJ4190 ball joint only or RH-BJ4156 LH-BJ4157 inc. arm		TE926 95mm long	TE926 95mm long			P191027 300mm male					BJ4156/4157 - complete arms ** these are NOT 'Y' shaped arms ***
5/96-2000	Pulsar N15													
2000-on	Pulsar N16													
	SERENA													
1991-on	Serena AC23				TE980	TE980			RE987					
	SKYLINE													
1977-81	Skyline C210 sedan & coupe		BJ151	SX4254	TE520L	TE520L	TE521R	TE521R		TR656	TR417			TR656 - consists of TE520L / TE521R / AS656 Adjusting sleeve - AS656 (18x1.5) 100mm o/all lgh
8/81-7/85	Skyline R30 sedan & hatch		RH-BJ544 LH-BJ545 inc. arm	SX1232	TE668	TE668	TE669	TE669			TR426			
1986-8/89	Skyline R31 - imported steering rack		BJ274		TE714P 235mm long	TE714P 235mm long			RE859** 150mm male or RE955** 280mm male					TE714P - 235mm Long ** Rack end - For Skyline full import GTS use RE955
1986-8/89	Skyline R31 - TRW steering rack		BJ274		TE714 221mm long	TE714 221mm long			P191006					TE714 - 221mm Long
9/89-93	Skyline R32		BJ6001	OEM0368K idler bush	TE7125	TE7125			RE4760					

STEERING and SUSPENSION COMPONENTS



YEAR	MODEL	BALL JOINT UPPER	BALL JOINT LOWER / KING PIN SET	IDLER	TIE ROD END L/H OUTER	TIE ROD END R/H OUTER	TIE ROD END L/H INNER	TIE ROD END R/H INNER	RACK END	SIDE ROD	CENTRE ROD	DRAG LINK	PITMAN	NOTES/OTHER
------	-------	------------------	---------------------------------	-------	-----------------------	-----------------------	-----------------------	-----------------------	----------	----------	------------	-----------	--------	-------------

				(2WD only)										
	Skyline R33													
	Skyline R34													
STANZA														
1977-81	Stanza A10 series inc. Violet		BJ163	SX1136	TE518L	TE518R	TE519R	TE519L	P189014 132mm female	RH-TR634 LH-TR633	see Drag Link	TR558		If TRW rack present - no inners etc. required. Instead use rack end P189014
6/81-85	Stanza T11 series		RH-BJ240R LH-BJ240L		TE664	TE664				TR4480				TR4480 - consists of TE664 / RE857
10/85-on	Stanza T12, T12Y		BJ241		TE665	TE665				TR683				
SUNNY														
1971-77	Sunny PB110, PB210, GB211		BJ85	SX1121	TE437L	TE437R	TE438R	TE438L		RH-TR413R LH-TR414L				TR413R - consists of TE437R / TE438L / CR655 Cpmnecting rod - CR655 (14x1.5) 166mm o/all lgth
1978-82	Sunny B310 1.2lt - models with 12mm ball joint mount bolts		BJ176	SX1136	TE518L	TE518R	TE519R	TE519L		RH-TR634 LH-TR633		TR558		
1978-82	Sunny B310 1.4lt, 1.5lt - models with 10mm ball joint mount bolts		BJ163	SX1136	TE518L	TE518R	TE519R	TE519L		RH-TR634 LH-TR633		TR558		
SYLVIA - see GAZELLE														
Z series - see 240Z,260Z,280ZX,300ZX														

NISSAN - Commercial														
1000 UTILITY														
1967-70	Datsun 1000 B10,RB10,VB10,B20 outer's have 12mm thread	BJ89	BJ91		TE187L 12mm thread	TE187R 12mm thread	TE183R	TE183L						Outer tie rod ends - 12mm thread
1967-70	Datsun 1000 B10,RB10,VB10,B20 outer's have 14mm thread	BJ89	BJ91		TE437L 14mm thread	TE437R 14mm thread	TE183R	TE183L						Outer tie rod ends - 14mm thread
1200 UTILITY														
1974-76	Datsun 1200 Ute 120Y, UB210 300kg		BJ92 4 bolt mount	SX1136	TE518L	TE518R	TE519R	TE519L				TR412		BJ92 mounting holes 41mm centre-to-centre
1976-78	Datsun 1200 Ute 120Y, UB210 300kg		BJ176	SX1136	TE518L	TE518R	TE519R	TE519L				TR412		BJ176 mounting holes 51mm

STEERING and SUSPENSION COMPONENTS

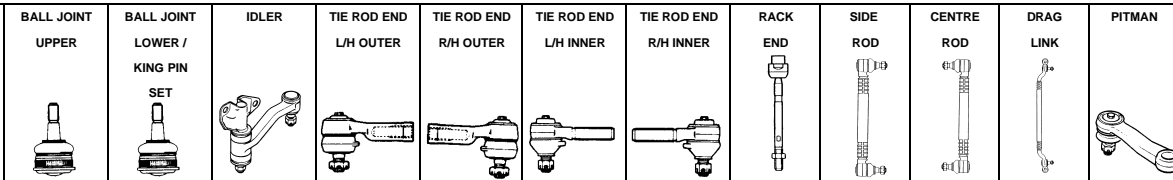

O.R.I.G.I.N.A.L.

N.I.S.S.A.N.

YEAR	MODEL	BALL JOINT UPPER	BALL JOINT LOWER / KING PIN SET	IDLER	TIE ROD END L/H OUTER	TIE ROD END R/H OUTER	TIE ROD END L/H INNER	TIE ROD END R/H INNER	RACK END	SIDE ROD	CENTRE ROD	DRAG LINK	PITMAN	NOTES/OTHER
			4 bolt mount											centre-to-centre
1978-on	Datsun 1200 Ute				TE518L	TE518R	TE519R	TE519L			TR409			
	300C - see NISSAN 240C,260C,280C,300C DATSUN													
	320, 520, 620, 720, 2WD													
1963-72	Datsun 320, 520 & 521 Ute 2WD		KX230	SX1151	TE671L	TE671R				RH-TR433 LH-TR434	RH-TE432L LH-TE432R			Upper inner arm repair kit - SX1120A King pin set - 0.787" x 4.560" (20x116mm)
1972-8/77	Datsun 620 Ute 2WD		KX260	SX1151	TE546L	TE545R				RH-TR433 LH-TR434	TR420			TE432R&L can be used to replace ends on centre rod King pin set - 0.787" x 4.920" (20x125mm)
9/77-9/79	Datsun 620 Ute 2WD		BJ205	RH-BJ206 LH-BJ207	SX1152	TE546L	TE545R			RH-TR433 LH-TR434	TR420			TE432R&L can be used to replace ends on centre rod
9/79-3/83	Datsun 720 2WD		BJ205	RH-BJ206 LH-BJ207	SX1153	TE604R 'short' with LH thread	TE604R 'long' with RH thread	TE604L TE604L			TR661	TR614		
4/83-85	Datsun 720 2WD		BJ205	RH-BJ206 LH-BJ207	SX1223	TE604R 'short' with LH thread	TE604R 'long' with RH thread	TE604L TE604L			TR661	TR679		
	720 (4WD)													
4/80-3/83	Nissan 720 4WD		BJ205	RH-BJ206 LH-BJ207	SX1217	TE604R	TE604R	TE674R** 18mm thread	TE674R** 18mm thread		TR663	TR681		**Tie rod ends - check dimensions
1983-85	Nissan 720 4WD - manual steer		BJ205	BJ222	SX1224	TE675L	TE675R	TE676R 16mm LH thread	TE676L 16mm RH thread		RH-TR664R LH-TR664L		SX1226	
1983-85	Nissan 720 4WD - power steer		BJ205	BJ222	SX1225	TE675L	TE675R	TE676R 16mm LH thread	TE676L 16mm RH thread		RH-TR664R LH-TR664L		SX1227	
	 720 4x4 1982-85 Single/Dual/King Cab	Front Spring Rear Pin	Front Spring Front Shackle L/H	Front Spring Front Shackle R/H	Rear Spring Front Pin P800	Rear Spring Rear Shackle L/H S799K	Rear Spring Rear Shackle R/H S799K							Shackle & Pin Kits
	C20 - see VANETTE													
	CABALL													
1967-72	Caball C240 2ton		KX252		TE473L**	TE473R**								King pin set - 25 x 168mm ** Tie rod end config, different on some models - check thread

STEERING and SUSPENSION COMPONENTS



YEAR	MODEL	BALL JOINT UPPER	BALL JOINT LOWER / KING PIN SET	IDLER	TIE ROD END L/H OUTER	TIE ROD END R/H OUTER	TIE ROD END L/H INNER	TIE ROD END R/H INNER	RACK END	SIDE ROD	CENTRE ROD	DRAG LINK	PITMAN	NOTES/OTHER
------	-------	------------------	---------------------------------	-------	-----------------------	-----------------------	-----------------------	-----------------------	----------	----------	------------	-----------	--------	-------------

Commercial

1973-76	Caball C240 2ton		KX265		TE473L**	TE473R**								King pin set - 25 x 170mm ** Tie rod end config, different on some models - check thread
1977-71	Caball C340 2ton		KX266		TE473L**	TE473R**								King pin set - 25 x 172mm ** Tie rod end config, different on some models - check thread
CABSTAR														
3/76-4/78	Cabstar F20, F21	BJ183	BJ184		TE570L	TE570R				RH-TR636R LH-TR635L				TE570L&R - 211mm M20x1.5 with bend
4/78-81	Cabstar F21	BJ183	BJ184		TE570L	TE570R				RH-TR638R LH-TR637L				TE570L&R - 211mm M20x1.5 with bend
1982-86	Cabstar PF22, EF22	BJ205	RH-BJ206 LH-BJ207							RH-TR638R LH-TR637L				
	Cabster FGH40, KMH40		KX266											King pin set - 25 x 172mm
DX, ST UTILITY (rebadged FALCON)														
1988-90	DX Ute - manual steer	BJ94	BJ75	SX1119 or SX1119U or OEM644K	TE548R	TE548R	TE549L	TE549L					SX809 (18901)	Spring saddle (rubber) - XR3388A (single) Spring saddle (urethane) - OEM335K (pair) Camber pin kit - F67 SX1119 - rubber bush's both ends SX1119U - rubber/urethane combination OEM644K - urethane bush's both ends
1988-90	ST Ute - power steer	BJ94	BJ75	SX1119 or SX1119U or OEM644K	TE548R	TE548R	TE549L	TE549L					SX809B (18902)	Spring saddle (rubber) - XR3388A (single) Spring saddle (urethane) - OEM335K (pair) Camber pin kit - F67 SX1119 - rubber bush's both ends SX1119U - rubber/urethane combination OEM644K - urethane bush's both ends
E20 - see URVAN														
ESCARGO														
	ESCARGO				TE664	TE664								
HOMER														
1969-76	Homer T20, T640, T641	BJ138	BJ140		TE502L	TE502R				RH-TR638R LH-TR637L				
3/76-4/78	Homer F20, F21	BJ183	BJ184		TE570L	TE570R				RH-TR636R LH-TR635L				

Niss

STEERING and SUSPENSION COMPONENTS



YEAR	MODEL	BALL JOINT UPPER	BALL JOINT LOWER / KING PIN SET	IDLER	TIE ROD END L/H OUTER	TIE ROD END R/H OUTER	TIE ROD END L/H INNER	TIE ROD END R/H INNER	RACK END	SIDE ROD	CENTRE ROD	DRAG LINK	PITMAN	NOTES/OTHER
------	-------	------------------	---------------------------------	-------	-----------------------	-----------------------	-----------------------	-----------------------	----------	----------	------------	-----------	--------	-------------

R - C O E B O C I A R

4/78-1982	Homer F20, F21, F22	BJ205	RH-BJ206 LH-BJ207		TE570L	TE570R								RH-TR638R LH-TR637L	
1982-87	H40				TE473L	TE473R									
2004-on	MARANO Marano 4WD														
1/86-3/97	NAVARA (2WD) Navara D21 series	BJ205	BJ244	SX1219 idler arm	TE672L	TE672L	TE673R	TE673R						TR662 TR680 m/steer or TR4671 (with bracket) p/steer	
4/97-2002	Navara D22 series	BJ4821	BJ244	SX4670	TE4821 LH Thread Male	TE4821 LH Thread Male	TE4822 RH Thread Male	TE4822 RH Thread Male						TR4820	Tie Rod Ends - Check Threads - various arrangements have been identified.
4/97-2002	Navara D22 Pickup/Utility	BJ4821	BJ244	SX2485	TE4831 RH Thread Female	TE4833									Tie Rod Ends - Check Threads - various arrangements have been identified.
8/85-90	NAVARA (4WD) Navara D21 series	BJ205	BJ222	SX1221	TE703 RH thread	TE703 RH thread	TE704 LH thread	TE704 LH thread						TR677 TR678	SX1221 - 3 mounting holes
1990-8/92	Navara D21 series	BJ824	BJ825	SX1221	TE704 LH thread or TE4752 BLD-14.5mm BHD-16mm	TE703 RH thread or TE4751 BHD-16mm	TE703 RH thread or TE4751 BLD-14.5mm BHD-16mm	TE704 LH thread or TE4752						TR677 TR678 TR678 only suits TE703/TE704 tie rod ends	Tie Rod Ends - if taper on TE703/TE704 is too small - use TE4751/TE4752
9/92-on	Navara D21 series	BJ824	BJ825	SX1221	TE4752 LH thread	TE4751 RH thread	TE4751 RH thread	TE4752 LH thread						TR5625	SX8525 to 8/93 Tie Rod Ends - Check Threads - various arrangements have been identified.

N

STEERING and SUSPENSION COMPONENTS



YEAR	MODEL	BALL JOINT UPPER	BALL JOINT LOWER / KING PIN SET	IDLER	TIE ROD END L/H OUTER	TIE ROD END R/H OUTER	TIE ROD END L/H INNER	TIE ROD END R/H INNER	RACK END	SIDE ROD	CENTRE ROD	DRAG LINK	PITMAN	NOTES/OTHER
------	-------	------------------	---------------------------------	-------	-----------------------	-----------------------	-----------------------	-----------------------	----------	----------	------------	-----------	--------	-------------

ISUZU COERCION

														SX8526 9/92-on	
4/97-2002	Navara D22 series		BJ4802	SX2625 1998-02	TE4832 LH Thread Female	TE4831 RH Thread Female	TE4831 RH Thread Female	TE4832 LH Thread Female							Tie Rod Ends - Check Threads - various arrangements have been identified.
	 Navara 4x4 1987-on IFS Single / Dual / King Cab	Front Spring Rear Pin	Front Spring Front Shackle L/H	Front Spring Front Shackle R/H	Rear Spring Front Pin PK276	Rear Spring Rear Shackle L/H SK276	Rear Spring Rear Shackle R/H SK276								Shackle & Pin Kits
	NOMAD														
6/81-8/85	Nomad WSC22	BJ210	BJ211	SX1156	TE3647R 85mm long	TE3647L 85mm long	TE3649L 108mm long	TE3649R 108mm long		RH-TR446 LH-TR447	TR430	DL302		DL302 - manual steering only DL302 - overall length 840mm	
9/85-88	Nomad CG22	BJ210	BJ211	SX4263	TE3647R 85mm long	TE3647L 85mm long	TE3649L 108mm long	TE3649R 108mm long		RH-TR446 LH-TR447	TR430	DL302		DL302 - manual steering only DL302 - overall length 840mm	
1988-on	Nomad C22, C23 Wagon, Seriena, Vanette			OEM1288K idler bush											
	PATHFINDER / TERRANO														
8/86-93	Pathfinder WD21, VD21 4WD	BJ205	BJ222	SX1221	TE703 RH thread	TE703 RH thread	TE704 LH thread	TE704 LH thread		TR677	TR678				
1/93-on	Pathfinder HYD21 4WD	BJ824	BJ825		TE4751 RH thread	TE4751 RH thread	TE4752 LH thread	TE4752 LH thread						Tie Rod Ends - Check Threads - various arrangements have been identified.	
1996-02	Pathfinder R50 4WD		BJ2483		TE2480	TE2480			RE2483						

STEERING and SUSPENSION COMPONENTS

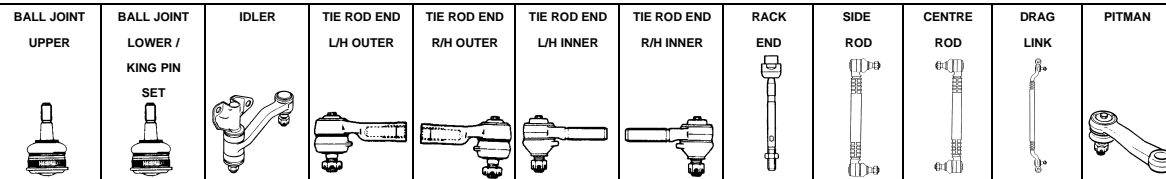

YEAR	MODEL	BALL JOINT UPPER	BALL JOINT LOWER / KING PIN SET	IDLER	TIE ROD END L/H OUTER	TIE ROD END R/H OUTER	TIE ROD END L/H INNER	TIE ROD END R/H INNER	RACK END	SIDE ROD	CENTRE ROD	DRAG LINK	PITMAN	NOTES/OTHER
------	-------	------------------	---------------------------------	-------	-----------------------	-----------------------	-----------------------	-----------------------	----------	----------	------------	-----------	--------	-------------

Nissan Commercial

	PATROL													
1965-80	Patrol G60 series 4WD				TE473L 22mm LH thread	TE473L 22mm LH thread								
1980-87	Patrol MQ/MK 4WD - manual steer			SX417 steering idler kit	TE3664R	TE473L 22mm LH thread or TE1403 12/82-on - 25mm					TR411 Relay Rod 322mm has hole o pin to damper)	DL300 705mm	SX5310	TE3664R - has hole to accept drag link
1980-87	Patrol MQ/MK 4WD - power steer			SX417 steering idler kit	TE3664R	TE473L 22mm LH thread or TE1403 12/82-on - 25mm					TR423 Relay Rod 322mm has pin	DL300 705mm	SX5311	TE3664R - has hole to accept drag link
10/87-on	Patrol Y60 series										TR560 Cross Rod 322mm	DL680 leaf spring 705mm		DL680 - only fits leaf spring utes mg

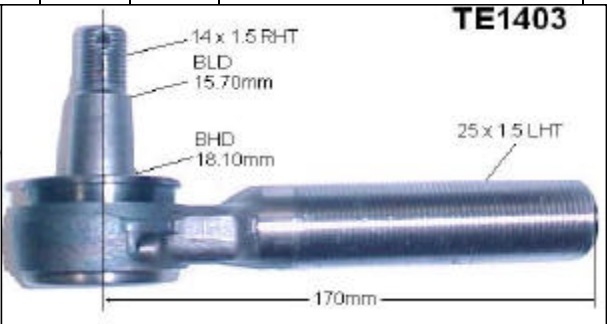
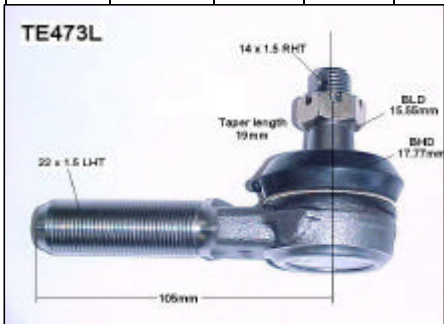
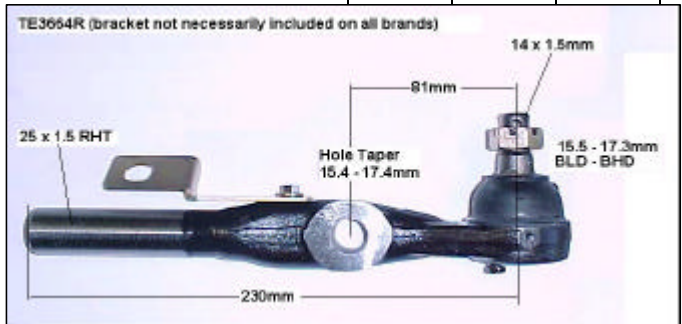

STEERING and SUSPENSION COMPONENTS



YEAR	MODEL	BALL JOINT UPPER	BALL JOINT LOWER / KING PIN SET	IDLER	TIE ROD END L/H OUTER	TIE ROD END R/H OUTER	TIE ROD END L/H INNER	TIE ROD END R/H INNER	RACK END	SIDE ROD	CENTRE ROD	DRAG LINK	PITMAN	NOTES/OTHER
------	-------	------------------	---------------------------------	-------	-----------------------	-----------------------	-----------------------	-----------------------	----------	----------	------------	-----------	--------	-------------

1988-6/92	Patrol GQ 4WD - Y60 series - WAGON				TE984 22mm LH thread	TE979 22mm RH thread					TR423 Relay Rod 322mm	DL690 1988 to 8/89 use with Monroe SC2914 Steering Damper or DL700 9/89-on coil springs 1120mm	SX5306	Tie Rod Ends - Wagon only DL690 - 1988-8/89 must be used with Monroe SC2914 Steering Damper DL700 - only fits coil springs 9/89-on
1988-10/91	Patrol GQ 4WD - Y60 series - power steer - UTE / TRAY				TE1403 25mm LH thread	TE3664R drag link hole					TR423 Relay Rod 322mm	DL690 1988 to 8/89 use with Monroe SC2914 Steering Damper or DL700 9/89-on coil springs 1120mm	SX5307	Tie Rod Ends - Wagon only DL690 - 1988-8/89 must be used with Monroe SC2914 Steering Damper DL700 - only fits coil springs 9/89-on
1988-10/91	Patrol GQ 4WD - Y60 series - manual steer - UTE / TRAY				TE3664R drag link hole	TE1403 25mm LH thread					TR423 Relay Rod 322mm	DL690 1988 to 8/89 use with Monroe SC2914 Steering Damper or DL700 9/89-on coil springs 1120mm	SX5308	Tie Rod Ends - Wagon only DL690 - 1988-8/89 must be used with Monroe SC2914 Steering Damper DL700 - only fits coil springs 9/89-on
8/93-98	Patrol GQ 4WD				TE984 22mm LH thread	TE979 22mm RH thread					TR423 Relay Rod 322mm	DL690 1988 to 8/89 use with Monroe SC2914 Steering Damper or DL700 9/89-on coil springs 1120mm	SX5309	Tie Rod Ends - Wagon only DL690 - 1988-8/89 must be used with Monroe SC2914 Steering Damper DL700 - only fits coil springs 9/89-on

Nissan - O.E.M. -

STEERING and SUSPENSION COMPONENTS

YEAR	MODEL	BALL JOINT UPPER	BALL JOINT LOWER / KING PIN SET	IDLER	TIE ROD END L/H OUTER	TIE ROD END R/H OUTER	TIE ROD END L/H INNER	TIE ROD END R/H INNER	RACK END	SIDE ROD	CENTRE ROD	DRAG LINK	PITMAN	NOTES/OTHER
------	-------	------------------	---------------------------------	-------	-----------------------	-----------------------	-----------------------	-----------------------	----------	----------	------------	-----------	--------	-------------

11/99-on	Patrol GQ Tray Back				TE5725L 20mm thread	TE5725R 20mm thread								
91-7/92	DX (base model) manual steer				TE984 22mm LH thread	TE979 22mm RH thread								
7/92-on	DX - Wagon GQ Y60 Tray				TE135L Female	TE135R Female								
1997-on	GU Y61													
	Patrol MQ - steel bush front of front lower 1981-83 Shackle & Pin Kits	Front Spring Rear Pin PK470	Front Spring Front Shackle L/H SK355	Front Spring Front Shackle R/H SK355	Rear Spring Front Pin PK470	Rear Spring Rear Shackle L/H SK664	Rear Spring Rear Shackle R/H SK664							
	Patrol MQ - rubber bush front of front lower 1983-86 Shackle & Pin Kits	Front Spring Rear Pin PK470	Front Spring Front Shackle L/H SK665	Front Spring Front Shackle R/H SK665	Rear Spring Front Pin PK470	Rear Spring Rear Shackle L/H SK664	Rear Spring Rear Shackle R/H SK664							
	Patrol GQ Trayback Shackle & Pin Kits	Front Spring Rear Pin PK667	Front Spring Front Shackle L/H SK666	Front Spring Front Shackle R/H SK666	Rear Spring Front Pin PK667	Rear Spring Rear Shackle L/H SK666	Rear Spring Rear Shackle R/H SK666							
	PULSAR VAN													
1982-on	Pulsar Van VB11 500kg		BJ242		TE664	TE664								TR654
	SUNNY													
1966-70	Sunny Truck B20	BJ89	BJ91		TE187L	TE187R	TE183L	TE183R						
1971-75	Sunny Truck B120		BJ92	SX1135	TE440L	TE440R	TE4092L	TE4092R	RH-TR659R LH-TR659L	TR409				
10/75-on	Sunny Truck B120, B121, B122		BJ176	SX1135	TE518L	TE518R	TE519R	TE519L	RH-TR4120R LH-TR4120L	TR409				
1978-83	Sunny Van VB310 350kg		BJ176	SX1135	TE518L	TE518R	TE519R	TE519L						TR558

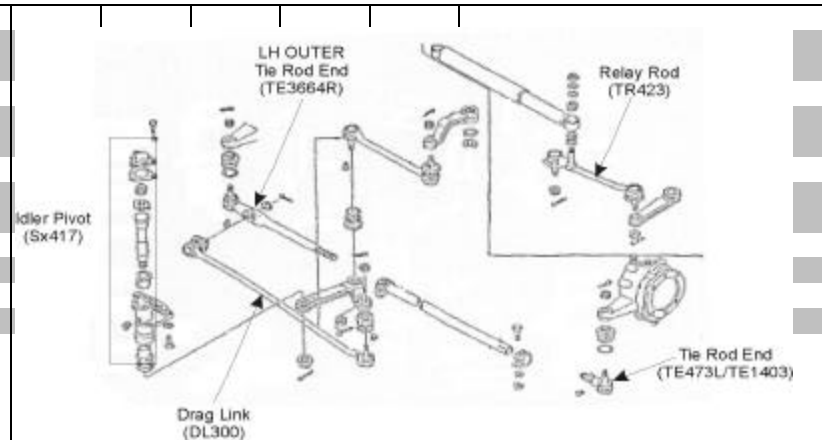

BUSINESS - COMMERCIAL

STEERING and SUSPENSION COMPONENTS

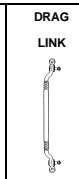
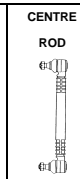
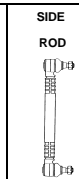
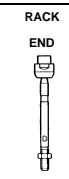
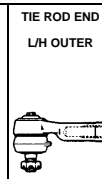
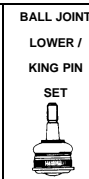

YEAR	MODEL	BALL JOINT UPPER	BALL JOINT LOWER / KING PIN SET	IDLER	TIE ROD END L/H OUTER	TIE ROD END R/H OUTER	TIE ROD END L/H INNER	TIE ROD END R/H INNER	RACK END	SIDE ROD	CENTRE ROD	DRAG LINK	PITMAN	NOTES/OTHER
------	-------	------------------	---------------------------------	-------	-----------------------	-----------------------	-----------------------	-----------------------	----------	----------	------------	-----------	--------	-------------

TERRANO - see PATHFINDER														
TRUCK														
1971-75	Junior 140,N140 (1600) 30cwt truck	BJ138	BJ140											LH-TE402L
1972-on	Nissan UG780 / TK10		KX123											
	Nissan UD Truck CMA86 & 87		KX133											
1979-on	Nissan UD Truck CD50/51, CW50/51, PD, RD				TE677L	TE677R								
	Nissan CU40 / CD		KX136											
1979-84	CWA45, CW40, CK11, GVW 24000kg		KX264											King pin set - 47 x 239mm
URVAN														
74-11/75	Urvan E20	BJ138	BJ140		TE502L	TE502R								RH-TR636R LH-TR635L
11/75-78	Urvan E20, E21, E22, E23	BJ183	BJ184		TE570L	TE570R								RH-TR636R LH-TR635L TR636 - 420mm long TR635 - 420mm long
1978-86	Urvan E20, E21, E22, E23	BJ205	RH-BJ206 LH-BJ207		TE570L	TE570R								RH-TR638R LH-TR637L TR638 - 390mm long TR637 - 390mm long
1987-93	Urvan E24 2WD	BJ205	BJ244		TE859	TE858	TE858	TE859		TR445	TR429	DL301		
VANETTE, C20														
1968-76	Vanette C80, SC80 series 3500kg		KX251		TE437L	TE437R								King pin set - 30 x 183mm
1975-78	Vanette C20, C21	BJ208	BJ209	SX1154	TE187R	TE187R	TE187L	TE187L		TR610		DL400		
10/78-6/81	Vanette C120, C121 excl. Z/LD20	BJ208	BJ211	SX1155	TE437R	TE437L	TE438L	TE438R		RH-TR612 LH-TR613	TR407	DL401		
6/81-9/85	Vanette C120, C122 incl. Z/LD20	BJ210	BJ211	SX1156	TE437R	TE437L	TE438L	TE438R		RH-TR612 LH-TR613	TR407	DL401		
9/85-93	Vanette C22	BJ210	BJ211	SX4263	TE3647L	TE3647R	TE3649L	TE3649R		RH-TR446 LH-TR447	TR430	DL302 m/steer only length 840mm		DL302 - overall length 840mm - m/steer only
X TRAIL														
10/01 - 12/03	X Trail 2.5L T30													

Nissan COEOR

STEERING and SUSPENSION COMPONENTS



YEAR	MODEL	BALL JOINT UPPER	BALL JOINT LOWER / KING PIN SET	IDLER	TIE ROD END L/H OUTER	TIE ROD END R/H OUTER	TIE ROD END L/H INNER	TIE ROD END R/H INNER	RACK END	SIDE ROD	CENTRE ROD	DRAG LINK	PITMAN	NOTES/OTHER
------	-------	------------------	---------------------------------	-------	-----------------------	-----------------------	-----------------------	-----------------------	----------	----------	------------	-----------	--------	-------------

OLDSMOBILE

OLDSMOBILE														
1941-60	Oldsmobile - all models		KX26		TE52R	TE52R								
1961-72	Cutlass, Cutlass Supreme Classic, F85, Vista Cruiser, Calais	BJ54	BJ55 or BJ55OS (oversize)		TE52R	TE52R								
1973-74	Omega	BJ54	BJ55 or BJ55OS (oversize)		TE52R	TE52R								
1973-88	Cutlass, Cutlass Supreme Classic, F85, Vista Cruiser, Calais	10268	305-153	18765 (1973-74) 18799 (1978-88)										

PEUGEOT

PEUGEOT														
205 series														
9/99-on	205 series				TE1718	TE1718								
206 series														
9/99-on	206 series				TE434R	TE435R			RE3010					
306 series														
1999-on	306 series - power steer		BJ581		TE2234R	TE2234R			RE3437					
406 series														
1999-on	406 series		BJ989		TE534R	TE534R			RE3540					
504 series														
1968-80	504 to chassis# 3221370		BJ894RK repair kit only		TE9918K repair kit only	TE3638R								TE9918K - repair kit only
1974-84	504 sedan & wagon - to chassis# 3692053		BJ894RK repair kit only		TE3638R	TE3638R								BJ894RK - repair kit only up to '82 BJ894 - complete assembly for '82 on
1974-84	504 sedan & wagon - from chassis# 3692054		BJ894 complete assembly		TE3638R	TE3638R								BJ894RK - repair kit only up to '82 BJ894 - complete assembly for '82 on
505 series														
1979-93	505 sedan & wagon - to chassis# 1341364		BJ894RK repair kit only		TE3638R	TE3638R								BJ894RK - repair kit only up to '82 BJ894 - complete assembly for '82 on

STEERING and SUSPENSION COMPONENTS



YEAR	MODEL	BALL JOINT UPPER	BALL JOINT LOWER / KING PIN SET	IDLER	TIE ROD END L/H OUTER	TIE ROD END R/H OUTER	TIE ROD END L/H INNER	TIE ROD END R/H INNER	RACK END	SIDE ROD	CENTRE ROD	DRAG LINK	PITMAN	NOTES/OTHER
------	-------	------------------	---------------------------------	-------	-----------------------	-----------------------	-----------------------	-----------------------	----------	----------	------------	-----------	--------	-------------

1979-93	505 sedan & wagon - from chassis# 1341365		BJ894 complete assembly		TE3638R	TE3638R								BJ894RK - repair kit only up to '82 BJ894 - complete assembly for '82 on
	604 series													
1975-84	604 sedan & wagon - to chassis# 6607525		BJ894RK repair kit only		TE3638R	TE3638R								BJ894RK - repair kit only up to '82 BJ894 - complete assembly for '82 on
1975-84	604 sedan & wagon - from chassis# 6607526		BJ894 complete assembly		TE3638R	TE3638R								BJ894RK - repair kit only up to '82 BJ894 - complete assembly for '82 on
	605 series													
1999-on	605 series		BJ989		TE434R	TE435R								
	607 series													
1999-on	607 series													

PLYMOUTH

1941-56	P11,P12,P14,P15,P17,P18,P19,P20,P22 P23,P24,P25,P26,P28 (except 7 pass.sedan & limo)				TE49L	TE49R	TE49R	TE49L						
1953-54	Cambridge, Cranbrook P24-1,P24-2,P25-1; P25-2 to serial# 1560 (Australian production)		KX22	SX1040	TE114L	TE114L								
1954-57	Cambridge,Cranbrook P25-2 serial# 1561 on; Belvedere, Savoy P25-3,P25-4 (Australian production)		KX21	SX1040	TE114L	TE114L								
1956-57	Utility P25A-2 to serial# 482 (except 370-392 inc.) P25A-3 to serial# 105, P25A-4 to serial# 44 (Australian production)		KX21		TE114L	TE114L								
1957-74	all models	BJ8	BJ9	SX1103A	TE173R	TE173R	TE173L	TE173L						
1965-78	Fury	BJ8			TE173R	TE173R	TE173L	TE173L						
1960-72	Barracuda	BJ18												
1972-74	Barracuda, Cuda	BJ8			TE173R	TE173R	TE173L	TE173L						
1970-73	Belvedere, Satellite, Roadrunner	BJ8	BJ9		TE173R	TE173R	TE173L	TE173L						BJ9 - 1973 only



STEERING and SUSPENSION COMPONENTS















YEAR	MODEL	BALL JOINT UPPER	BALL JOINT LOWER / KING PIN SET	IDLER	TIE ROD END L/H OUTER	TIE ROD END R/H OUTER	TIE ROD END L/H INNER	TIE ROD END R/H INNER	RACK END	SIDE ROD	CENTRE ROD	DRAG LINK	PITMAN	NOTES/OTHER
------	-------	------------------	---------------------------------	-------	-----------------------	-----------------------	-----------------------	-----------------------	----------	----------	------------	-----------	--------	-------------

O E M

1941-48	Series 24,25,26,27,28 all models		KX26	SX1028	TE52R	TE52R								
1949-54	Series 20 & 22 all models		KX20	SX1019	TE57R	TE57R	TE57L	TE57L						
1949-52	Chieftain, Streamliner, Silver Streak Series 25,27		KX26	SX1028	TE52R	TE52R								
1953-57	Chieftain, Star Chief, Streamliner, Super Chief				TE52R	TE52R								
1955-57	Laurentian, Pathfinder (Canadian origin)	BJ70	BJ3											
1958-70	Custom Sport, Fleet, Laurentian, Parisienne, Pathfinder, Safari, Strato Chief, Super Sport (Canadian origin)	BJ70	BJ71	18783	ES378L	ES378L	ES378R	ES378R						BANNAL
1969-72	Grand Prix	BJ54	BJ55 or BJ55OS (oversize)											
1971-74	Ventura	BJ54	BJ55 or BJ55OS (oversize)											
	BONNEVILLE, etc.													
1971-76	Bonneville, Catalina, Grandville, Grand Safari	10268	10267	18765 (1973-76)	ES403R	ES403R								
1977-81	Bonneville, Catalina, Grandville (RWD)	10268	305-153	18799	ES2019R	ES2019R	ES2020L	ES2020L						
1982-86	Bonneville, Catalina, Grandville (RWD)	10268	305-153	18799										
	FIREBIRD, TRANSAM													
1967	Firebird, Transam	BJ54	BJ55 or BJ55OS (oversize)	18718										
1968	Firebird, Transam	BJ54	BJ55 or BJ55OS (oversize)	18718	ES381R	ES381R								
1969	Firebird, Transam	BJ54	BJ55 or BJ55OS (oversize)											
1970-75	Firebird, Transam	10268	305-153	18753	ES404R	ES404R								

STEERING and SUSPENSION COMPONENTS



YEAR	MODEL	BALL JOINT UPPER 	BALL JOINT LOWER / KING PIN SET 	IDLER 	TIE ROD END L/H OUTER 	TIE ROD END R/H OUTER 	TIE ROD END L/H INNER 	TIE ROD END R/H INNER 	RACK END 	SIDE ROD 	CENTRE ROD 	DRAG LINK 	PITMAN 	NOTES/OTHER
------	-------	--	---	--	--	---	---	---	--	--	--	---	---	-------------













				(1972-75)										
1976-81	Firebird, Transam	10268	305-153	18753	ES441R	ES441R								
1982-92	Firebird, Transam	10268	305-153	18832	ES2226R	ES2226R								
1993-96	Firebird, Transam		305-153											
	GTO, LeMANS													
1964-72	GTO, LeMans, Grand AM	BJ54	BJ55											
1973-81	GTO, LeMans, Grand AM	10268	305-153	18765 (1973-74) 18799 (1978-81)										

**P
O
R
S
C
H
E**

PORSCHE														
1963-70	Porsche 901, 911		BJ9114		TE9112R	TE9112R M14x1.5 RH thread								
1970-89	Porsche 911, 911 Cabrio, 911 Targa		BJ9119 or BJ9117 (2.2T & 2.3T)		TE9112R	TE9112R M14x1.5 RH thread								
1970-89	Porsche 911 Turbo - 3.3 SC		BJ9119		TE9302R	TE9302R M14x1.5 RH thread			RE9303 M14x1.5 RHT					
1989-93	Porsche 911, 911 Cabrio, 911 Targa		BJ9644		TE9642R	TE9642R M14x1.5 RH thread								
1993-on	Porsche 911, 911 Cabrio		BJ9939		TE9133R	TE9131R M14x1.5 RH thread			TE9931					Tie Rod Assy inc. TE9131R + RE9931 = TR9334 Tie Rod Assy inc. TE9133R + RE9931 = TR9335
1969-75	Porsche 914		BJ9113		TE9112R	TE9112R M14x1.5 RH thread								
1975-77	Porsche 924, 924 Turbo - power steer	BJ3227			TE7111 female	TE7111 female			RE7110					BJ3227 - 15mm
1975-77	Porsche 924, 924 Turbo - manual steer	BJ3227			TE7118 male	TE7118 male			RE7119					BJ3227 - 15mm
1978-85	Porsche 924, 924 Turbo - power steer	BJ2022			TE7111	TE7111			RE7110					BJ2022 - 17mm

STEERING and SUSPENSION COMPONENTS



YEAR	MODEL	BALL JOINT UPPER 	BALL JOINT LOWER / KING PIN SET 	IDLER 	TIE ROD END L/H OUTER 	TIE ROD END R/H OUTER 	TIE ROD END L/H INNER 	TIE ROD END R/H INNER 	RACK END 	SIDE ROD 	CENTRE ROD 	DRAG LINK 	PITMAN 	NOTES/OTHER	
					female	female									
1978-85	Porsche 924, 924 Turbo - manual steer	BJ2022			TE7118 male	TE7118 male			RE7119						BJ2022 - 17mm
1977-85	Porsche 928, 928S		BJ7112		TE7115	TE7115									
1985-on	Porsche 928				TE7115	TE7115									
1981-89	Porsche 944 from chassis# DN402645 power steer	BJ2022			TE3226	TE3226			RE7120						
1981-89	Porsche 944 from chassis# DN402645 manual steer	BJ2022			TE7118	TE7118			RE7119						
1999-on	Porsche Boxster														
PROTON															
5/95-2002	Persona, Wira, M21 - sedan & coupe														
2/97-2002	Satria Gti - hatchback														
12/01/2002	Waja - sedan														
RAMBLER - see AMC															
RANGE ROVER - see LANDROVER															
RELIANT															
	Scimitar SE4-8														
	Scimitar SS1														
RENAULT															
	R12, R15, R16, R17														
1969-77	Renault R12	BJ105	BJ106		TE1415L	TE1415R	TE4297	TE4297							
1973-77	Renault R15, R17	BJ105	BJ106		TE1415L	TE1415R	TE4297	TE4297							
1968-78	Renault R16	BJ107	BJ108		TE1135L	TE1135R	TE4297	TE4297							
	R18, R19, R20, R25														
1980-83	R18 GTS	BJ105	BJ886		TE3641R	TE3641R			RE4193						
					14 x 1.5mm RH thread										

Renault

STEERING and SUSPENSION COMPONENTS



YEAR	MODEL	BALL JOINT UPPER	BALL JOINT LOWER / KING PIN SET	IDLER	TIE ROD END L/H OUTER	TIE ROD END R/H OUTER	TIE ROD END L/H INNER	TIE ROD END R/H INNER	RACK END	SIDE ROD	CENTRE ROD	DRAG LINK	PITMAN	NOTES/OTHER
------	-------	------------------	---------------------------------	-------	-----------------------	-----------------------	-----------------------	-----------------------	----------	----------	------------	-----------	--------	-------------

1991-on	R19 TXE, RT		BJ885		TE2174	TE2173								
1976-80	R20TL - to chassis# 160600	BJ332	BJ813		TE1767	TE1767								
1977-83	R20TS - to chassis# 48700	BJ2020	BJ795		TE3641R 14 x 1.5mm RH thread	TE3641R								6mm fixing
1977-83	R20TS - from chassis# 48701	BJ2020	BJ830		TE3641R 14 x 1.5mm RH thread	TE3641R								7mm fixing
11/83-92	R25	BJ4295	BJ4281		TE3641R 14 x 1.5mm RH thread	TE3641R								
	ESPACE													
1984-90	Espace	BJ887	BJ886		TE3641R 14 x 1.5mm RH thread	TE3641R			RE6302					
1991-on	Espace	BJ4295	BJ4281		TE3641R 14 x 1.5mm RH thread	TE3641R			RE6431					
	FUEGO													
1982-86	Fuego	BJ887	BJ886		TE3641R 14 x 1.5mm RH thread	TE3641R			RE4193					

RILEY														
1957-65	1.5 litre				TE126R	TE126R								
1961-69	Elf	BJ29	BJ29		TE179R	TE179R								BJ29 - Ball joint repair kit
1965-69	Kestrel 1100,1300	BJ37	BJ38		TE179R	TE179R								BJ37 - Ball joint repair kit BJ38 - Ball joint repair kit

**R
O
C
K**

ROCKWELL AXLES														
	17101,FG931,FG933,FG941,FG943 14600lb axle - king pin set with metal bush and 5.44" stud centre-to-end tie rod ends or with 5.75" stud		K582		310-222 (5.44") 310-229	310-223 310-228								King pin set with metal bushes - 1.7935" x 10.392"

STEERING and SUSPENSION COMPONENTS



YEAR	MODEL	BALL JOINT UPPER	BALL JOINT LOWER / KING PIN SET	IDLER	TIE ROD END L/H OUTER	TIE ROD END R/H OUTER	TIE ROD END L/H INNER	TIE ROD END R/H INNER	RACK END	SIDE ROD	CENTRE ROD	DRAG LINK	PITMAN	NOTES/OTHER
------	-------	------------------	---------------------------------	-------	-----------------------	-----------------------	-----------------------	-----------------------	----------	----------	------------	-----------	--------	-------------

**W
E
I
L**

	centre-to-ends tie rod ends				(5.75")									
	17101,FG931,FG933,FG941,FG943 14600lb axle - king pin set with composite bush and 5.44" stud centre-to-end tie rod ends or with 5.75" stud centre-to-end tie rod ends		K583		310-222 (5.44") 310-229 (5.75")	310-223 310-228								King pin set with composite bushes - 1.7935" x 10.392"
	FH901 16000lb & FL901 18000lb axle		300-210		310-229	310-228								Twin keyway king pin set with metal bushes - 1.9985" x 11.04"
	FF931 9000lb & FF931 12000lb axle		300-232		310-222	310-223								Twin keyway king pin set with metal bushes - 1.793" x 10.39"
	FL931 & FL933 - 16000/18000/20000lb axles with 7.37" stud centre-to-end tie rod ends or 5.75" stud centre-to end tie rod ends		300-216		310-283 (7.37") 310-229 (5.75")	310-284 310-228								Twin keyway king pin set with metal bushes - 1.999" x 11.21"

**R
O
V
E
R**

ROVER															
1948-64	Series 60,75,80,90,95,100,105,110				TE79L	TE79R								RE - TE79R LH - TE79L	Centre Rod - ends only TE79L & TE79R
	2000,2000TC,3500,3500S														
1963-78	2000, 2000TC, 3500, 3500S Coil Spring Suspension	BJ109	BJ110							DL1138				RH - TE449R LH - TE449L	Centre Rod - ends only TE449L & TE449R
	LANDROVER - see LANDROVER														
	QUINTET														
1981-86	Quintet SU series - ball joint & arm		BJ4247		TE681	TE681			RE849 male end						RE849 - overall length 29.5cm
1986-90	Quintet 416i				TE681	TE681			RE850 male end						RE850 - overall length 31.7cm
	RANGE ROVER - see LANDROVER														
	SD1														
1976-87	SD1 (3500,3500SE) 5 door hatchback		RH-BJ2016 LH-BJ2017		TE3625R	TE3625R									control arms

S

SAAB

STEERING and SUSPENSION COMPONENTS



YEAR	MODEL	BALL JOINT UPPER	BALL JOINT LOWER / KING PIN SET	IDLER	TIE ROD END L/H OUTER	TIE ROD END R/H OUTER	TIE ROD END L/H INNER	TIE ROD END R/H INNER	RACK END	SIDE ROD	CENTRE ROD	DRAG LINK	PITMAN	NOTES/OTHER
------	-------	------------------	---------------------------------	-------	-----------------------	-----------------------	-----------------------	-----------------------	----------	----------	------------	-----------	--------	-------------

1
a
a
b

1967-74	99 series	BJ1004	BJ1004		TE1422	TE1422								TE1422 - 1/2" x 20 UNF RHT female
1975-87	99 series 1.7 - 2.0L	BJ1004	BJ1004		TE1676	TE1676			RE8941					TE1676 - M14 x 1.5 RHT female
1984-86	90 series 2.0L	BJ1004	BJ1004		TE1676	TE1676			RE8941					TE1676 - M14 x 1.5 RHT female
1979-93	900 series - to chassis# K8993560	BJ1004	BJ1004		TE1676	TE1676			RE8941 to 10/86					TE1676 - M14 x 1.5 RHT female
1979-93	900 series - from chassis# K8993561	BJ1004	BJ1004		TE2768	TE2768			RE7088 11/86-on					TE2768 - M14 x 2 RHT
1993-on	900 series				TE2749R	TE2756R								TE2756R/TE2749R - ends only M16x2 RHT female
1985-on	9000 series	BJ1328	BJ1328		TE2366	TE2366			RE2250					TE2366 - M14 x 1.5 RHT female
1998-on	9.3 series				TE2749R	TE2756R								TE2756R/TE2749R - ends only M16 x 2 RHT

SCOUT - see INTERNATIONAL TRUCKS

S
e
a
t

SEAT														
CORDOBA														
11/93 - 10/95	Cordoba - manual steer		BJ7365		TE9811R	TE9812R			RE9803					
11/93 - 10/95	Cordoba - power steer		BJ7365		TE9811R	TE9812R			RE8803					
11/95-on	Cordoba SX		BJ7365		TE2281	TE2282			RH - RE2804 LH - RE2803					
11/95-on	Cordoba excl. SX		BJ7365		TE2281	TE2282			RH - RE2806 LH - RE2805					
IBIZA														
to 5/1984	Ibiza				TE415R	TE415R			RE2913					14 X 1.5
6/84-6/86	Ibiza				TE2406R	TE2406R			RE2449					12 X 1.5
7/86-6/93	Ibiza				TE2406R	TE2406R			RE9832					
8/93 - 10/95	Ibiza excl. 1.3 - manual steer		BJ7365		TE9811R	TE9812R			RE9803					

STEERING and SUSPENSION COMPONENTS



YEAR	MODEL	BALL JOINT UPPER	BALL JOINT LOWER / KING PIN SET	IDLER	TIE ROD END L/H OUTER	TIE ROD END R/H OUTER	TIE ROD END L/H INNER	TIE ROD END R/H INNER	RACK END	SIDE ROD	CENTRE ROD	DRAG LINK	PITMAN	NOTES/OTHER
8/93 - 10/95	lbiza excl. 1.3 - power steer		BJ7365		TE9811R	TE9812R			RE8803					
11/95-on	lbiza GTI		BJ7365		TE2281	TE2282			RH - RE2804 LH - RE2803					
11/95-on	lbiza excl. GTI		BJ7365		TE2281	TE2282			RH - RE2806 LH - RE2805					
TOLEDO														
3/91-96	Toledo - manual steer		BJ7365		TE9811R	TE9812R			RE9803					
3/91-96	Toledo - power steer		BJ7365		TE9811R	TE9812R			RE8803					
1/97-on	Toledo		BJ3485		TE9811R	TE9812R			RE3532					
SINGER														
1961-67	Vogue Mk I,II,III,IV (wishbone suspension)	BJ31	BJ32		TE125L	TE125L	TE125R	TE125R						
1961-63	Gazelle IIIC	BJ30	KX185		TE125L	TE125L	TE125R	TE125R						
1963-67	Gazelle V,VI (wishbone suspension)	BJ31	BJ32		TE125L	TE125L	TE125R	TE125R						
1967-70	Gazelle, Vogue (strut suspension)		BJ56	SX1130	TE125L	TE125L	TE125R	TE125R						SX1130 - Idler arm support assembly
SOARER - see TOYOTA Soarer														
SSANGYONG														
1993-on	Musso		BJ3011											
STUDEBAKER														
1951-62	Champion, Commander, Hawk, Lark, President with short outer tie rod ends	SX76	SX75		310-220	310-221	310-221	310-220						
1962-63	All models except Avanti with long outer tie rod ends	SX76	SX75				310-220	310-220						

STEERING and SUSPENSION COMPONENTS

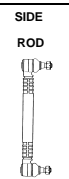
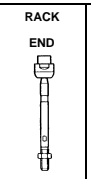
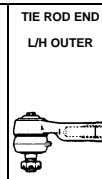
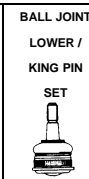

YEAR	MODEL	BALL JOINT UPPER	BALL JOINT LOWER / KING PIN SET	IDLER	TIE ROD END L/H OUTER	TIE ROD END R/H OUTER	TIE ROD END L/H INNER	TIE ROD END R/H INNER	RACK END	SIDE ROD	CENTRE ROD	DRAG LINK	PITMAN	NOTES/OTHER
------	-------	------------------	---------------------------------	-------	-----------------------	-----------------------	-----------------------	-----------------------	----------	----------	------------	-----------	--------	-------------

SUBARU

SUBARU														
1400 series														
1971-76	1400 sedan, coupe, wagon		BJ308		TE815R	TE815R								
1600 series														
1976-80	1600 sedan, coupe, wagon		BJ308		TE815R	TE815R								
BRUMBY														
1978-80	Brumby 1600 Ute 4x4		BJ308		TE815R	TE815R			RE7012					
									Female 300mm long					
1980-90	Brumby 1800 Ute 4x4		BJ257		TE694L	TE694R			RE860					
									Female 250mm long					
1991-on	Brumby Ute 4x4													
FORESTER														
	Forester													
IMPREZA														
1993-96	Imprezza		BJ3084		TE2975	TE2974			RE3414					
1997	Imprezza		BJ3084		TE8665	TE8665			RE3414					
1998-00	Imprezza		BJ3084		TE8665	TE8665			RE8665					
LEGACY (OUTBACK)														
1990-92	Legacy BC2, BC3, BC4, BC5		BJ3084		TE2975	TE2974			RE3414					
1993-94	Legacy		BJ3084		TE8665	TE8665			RE3414					
1995-97	Legacy		BJ3084		TE8665	TE8665			RE3414					
1998-02	Legacy		BJ3084		TE8666	TE8666			RE3410					
LEONE														
6/79-84	1800 sedan 2WD & 4WD, coupe, wagon 4WD AB2, AB4, AM1, AM2 - 2WD AB5, AJ5, AM3, AM5 - 4WD		BJ257		TE694L	TE694R			RE860					
									Female 250mm long					
									or					
									RE7012					
									Female 300mm long					

STEERING and SUSPENSION COMPONENTS



YEAR	MODEL	BALL JOINT UPPER	BALL JOINT LOWER / KING PIN SET	IDLER	TIE ROD END L/H OUTER	TIE ROD END R/H OUTER	TIE ROD END L/H INNER	TIE ROD END R/H INNER	RACK END	SIDE ROD	CENTRE ROD	DRAG LINK	PITMAN	NOTES/OTHER
------	-------	------------------	---------------------------------	-------	-----------------------	-----------------------	-----------------------	-----------------------	----------	----------	------------	-----------	--------	-------------

SUZUKI

6/84-88	1800 sedan 2WD & 4WD, wagon 4WD AL4, AL5 - manual steer		BJ257		TE701L	TE701R								RE876 - manual steer excluding Turbo
6/84-88	1800 sedan 2WD & 4WD, wagon 4WD AL4, AL5 - power steer		BJ257		TE701L	TE701R								RE877 - power steer
1988-94	1800 2WD & 4WD power steer		BJ257		TE987	TE986								
1989	LIBERTY L series manual steer				TE701L	TE701R								RE5006 (female)
1990-5/94	Liberty sedan, wagon & turbo DX, GX, LX 2WD & 4WD		BJ4141		TE2975	TE2974								RE6405
6/94-on	Liberty sedan, wagon & turbo GX, LX, RX 2WD & 4WD		BJ4141		TE2975	TE2974								RE6405
	OUTBACK - see LEGACY													
	VORTEX													
1985-91	Vortex XT turbo coupe - manual steer		BJ257		TE701L	TE701R								RE876 male end
1985-91	Vortex XT turbo coupe - power steer		BJ257		TE701L	TE701R								RE877 male end

SUNBEAM

1958-63	Rapier, Alpine Series I,II,III,IIIA		BJ30	KX185		TE125L	TE125L	TE125R	TE125R					
1963-67	Rapier, Alpine Series IV,V (wishbone suspension)		BJ31	BJ32		TE125L	TE125L	TE125R	TE125R					
1967-76	Rapier, Alpine, Arrow (strut suspension)		BJ56	SX1130		TE125L	TE125L	TE125R	TE125R					SX1130 - Idler arm support assembly

SUZUKI

	ALTO - see SUZUKI Commercial													
	BALENO Baleno													RE864

STEERING and SUSPENSION COMPONENTS



YEAR	MODEL	BALL JOINT UPPER	BALL JOINT LOWER / KING PIN SET	IDLER	TIE ROD END L/H OUTER	TIE ROD END R/H OUTER	TIE ROD END L/H INNER	TIE ROD END R/H INNER	RACK END	SIDE ROD	CENTRE ROD	DRAG LINK	PITMAN	NOTES/OTHER
------	-------	------------------	---------------------------------	-------	-----------------------	-----------------------	-----------------------	-----------------------	----------	----------	------------	-----------	--------	-------------

SWIFT														
1984-91	Swift SA,SF310,SF413 - one piece lower arm/ball joint AA41S, AA41V, AB41S		BJ400		TE3628R	TE3628R								
1991-97	Swift SF310, SF413, SF416		RH-BJ4158 LH-BJ4159		TE988	TE988			RE990					RE990 - Female 285mm long 12x1.25 TRE thread
1998-01	Swift													

SUZUKI - Commercial

ALTO														
79-8/84	Alto SS30V,SS40V,SS41V, SS80V - 4WD		BJ406		TE689R	TE689R			RE861 female end					
9/84-88	Alto CA71V, CA72V, CC71V, CC72V - 4WD		BJ4250		TE724R	TE724R			RE872					
1/91-on	Alto CL22V, CM22V, CR22S, CS22S				TE724R	TE724R								
CARRY/ST series														
1976-79	ST10,ST20 797cc 4cyl. van & truck				TE811L	TE811R	TE811R	TE811L						
1979-92	ST80,SV90,SK408 797cc 4cyl. van & truck		BJ407 (1980-85)		TE812L	TE812R	TE812R	TE812L						
1984-3/85	ST308 796cc 3cyl. van & truck				TE812L	TE812R	TE812R	TE812L						
ESCUDO - see VITARA														
HATCH														
1979-85	SS30V,SS40V,SS80V van & hatch		BJ406		TE689R	TE689R			RE861 female end					
JIMNY - see SIERRA														
L series														
1972-76	L50, L51, L60, L61 van & truck				TE811L	TE811R	TE811R	TE811L						

STEERING and SUSPENSION COMPONENTS

SUSPENSION

YEAR	MODEL	BALL JOINT UPPER 	BALL JOINT LOWER / KING PIN SET 	IDLER 	TIE ROD END L/H OUTER 	TIE ROD END R/H OUTER 	TIE ROD END L/H INNER 	TIE ROD END R/H INNER 	RACK END 	SIDE ROD 	CENTRE ROD 	DRAG LINK 	PITMAN 	NOTES/OTHER
------	-------	-------------------------	--	-----------	------------------------------	------------------------------	------------------------------	------------------------------	-----------------	-----------------	-------------------	------------------	------------	-------------

	LJ series (STOCKMAN 4WD)													
1974-78	LJ50, LJ51 - 4x4				TE690L	TE690R								DL306
1978-81	LJ80, LJ81 - 4x4				TE690L	TE690R	TE691R	TE691R						DL306
	MIGHTY BOY													
1985-88	Mighty Boy SS40T Utility		BJ406		TE689R	TE689R			RE861 female end					
	SIERRA / JIMNY													
7/77-82	Sierra SJ10, SJ20				TE690L	TE690R	TE691	TE691						DL306
5/81-6/83	Sierra SJ30. SJ31, SJ32				TE692L	TE692R	TE725	TE725						
7/83-on	Sierra SJ30. SJ31, SJ32, SJ33 SJ410, SJ411, SJ412, SJ413				TE692R	TE692R	TE693	TE693						DL307
8/82-on	Sierra SJ40, JA51, JA71				TE692R	TE692R	TE693	TE693						DL307
11/89-on	Sierra JA11C, JA11V				TE692R	TE692R	TE887	TE887						
	Sierra (Drover) SJ & LJ Series	Front Spring Rear Pin PK657	Front Spring Front Shackle L/H SK656	Front Spring Front Shackle R/H SK656	Rear Spring Front Pin PK657	Rear Spring Rear Shackle L/H SK656	Rear Spring Rear Shackle R/H SK656							Shackle & Pin Kits
	SUPER CARRY													
1985-89	Super Carry van & truck SK410 & 4WD				TE812L	TE812R	TE812R	TE812L						
	VITARA													
5/88-95	Vitara		BJ7542		TE692R	TE692R	TE7542	TE7542						
1995-98	Vitara - 3 door		BJ7542		TE7571	TE7571	TE7572	TE7572						
1995-98	Vitara - 5 door		BJ7542		TE692R	TE692R								
1999-02	Vitara				TE4867L	TE4767R			RE4867					
1999-02	Grand Vitara				TE4865L	TE4865R			RE4865					

SUSPENSION

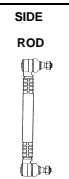
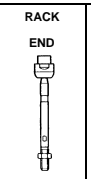
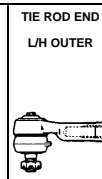
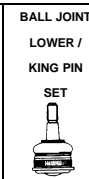

YEAR	MODEL	BALL JOINT UPPER	BALL JOINT LOWER / KING PIN SET	IDLER	TIE ROD END L/H OUTER	TIE ROD END R/H OUTER	TIE ROD END L/H INNER	TIE ROD END R/H INNER	RACK END	SIDE ROD	CENTRE ROD	DRAG LINK	PITMAN	NOTES/OTHER
------	-------	------------------	---------------------------------	-------	-----------------------	-----------------------	-----------------------	-----------------------	----------	----------	------------	-----------	--------	-------------

TOYOTA

TOYOTA														
	AVALON													
7/00-12/03	Avalon				TE2931	TE2931			RE2930					
	CAMRY inc. VIENTA													
3/82-87	Camry SV11 - 5 door hatch SV1# & CV1# series		BJ231 2 bolt mount		TE3687R	TE3687R			RE879 male end					
5/87-2/93	Camry SV20, SV21, SV22 1.8 & 2.0lt 4cyl. - Japanese steering rack power steer		BJ231 2 bolt mount		TE648	TE648			RE880					Japanese steering rack RE880 - 14mm dia. shaft & 14mm thread @ rack shaft end
5/87-2/93	Camry SV20, SV21, SV22 1.8 & 2.0lt 4cyl. - TRW steering rack power steer		BJ231 2 bolt mount		TE648	TE648			P191008					TRW steering rack
1987-3/90	Camry SV21 - manual steer		BJ231 2 bolt mount		TE648	TE648			RH-P191008 - 14mm dia. shaft & 16mm thread @ rack shaft end LH-P191009 - has recess for steering damper bracket					
11/92-6/97	Camry SVD10 2.2lt 4cyl. & Vienta VDV10 3.0lt V6		BJ301 3 bolt mount		TE751	TE751			P191020 (RE992)					
7/97-on	Camry SXV20, MCV70		BJ301 3 bolt mount											
	CELICA													
1971-9/75	Celica TA22, TE23 1.6lt coupe		BJ145	SX4239	TE489L	TE489L	TE490R 183mm long	TE490R 183mm long		TR565			SX5240	TE490R - 183mm long
10/75-77	Celica TA23, RA23, RA28 coupe & liftback		BJ145	SX4246	TE489L	TE489L	TE564R 170mm long	TE564R 170mm long		TR556			SX5241	TE564R - 170mm long
1977-7/81	Celica RA40 coupe & liftback		BJ145	SX1141	TE489L	TE489L	TE564R 170mm long	TE564R 170mm long		TR556			SX5241	TE564R - 170mm long
7/81-83	Celica RA60 coupe & liftback - manual steer		BJ145		TE640R	TE640R			RE878 male end					
7/81-83	Celica RA60 coupe & liftback - power steer		BJ145		TE641R	TE641R			RE878					

TOYOTA

STEERING and SUSPENSION COMPONENTS















YEAR	MODEL	BALL JOINT UPPER	BALL JOINT LOWER / KING PIN SET	IDLER	TIE ROD END L/H OUTER	TIE ROD END R/H OUTER	TIE ROD END L/H INNER	TIE ROD END R/H INNER	RACK END	SIDE ROD	CENTRE ROD	DRAG LINK	PITMAN	NOTES/OTHER
------	-------	------------------	---------------------------------	-------	-----------------------	-----------------------	-----------------------	-----------------------	----------	----------	------------	-----------	--------	-------------

									male end					
1983-12/85	Celica RA65, SA63 coupe & liftback - manual steer		BJ145		TE640R	TE640R				RE878 male end				
1983-12/85	Celica RA65, SA63 coupe & liftback - power steer		BJ145		TE641R	TE641R				RE878 male end				
8/85-8/89	Celica ST162 coupe & liftback		BJ260		TE648	TE648				RE880 - 14mm dia. shaft & 14mm thread @ rack shaft end				
8/89-94	Celica ST184, ST185 coupe & liftback		BJ365		TE648	TE648				RE2970 - overall length 355mm (10mm longer than RE880)				
1990-on	Celica ST204, ST205 coupe & liftback		BJ550											
	COROLLA													
1967-70	Corolla 1000 KE10,KE15,KE16		BJ111	SX1127	TE426L coarse thread	TE426L coarse thread	TE425R coarse thread	TE425R coarse thread					SX5238	coarse thread tie rod end
1967-70	Corolla 1200 KE11,KE17,KE18		BJ111	SX1127	TE534L fine thread	TE534L fine thread	TE535R fine thread	TE535R fine thread					SX5238	fine thread tie rod end
1970-74	Corolla 1200/1400/1600 KE20,KE25,KE26		BJ113 ball joint	SX1131	TE428L	TE428L	TE427R	TE427R		TR644			SX5208	
			RH-BJ5201R LH-BJ5201L inc. arm											
74-9/81	Corolla 1200/1300/1400/1500/1600 KE30, KE35,KE36,KE38,KE50,KE55		BJ145 ball joint	SX1139	TE489L	TE489L	TE490R	TE490R		TR565			SX5209	
			RH-BJ5202R LH-BJ5202L inc. arm											
8/79-5/83	Corolla T18 (TE72)		BJ145	SX1140	TE489L	TE489L	TE564R	TE564R		TR566	TR676		SX5203	
8/81-12/84	Corolla KE70 VAN - fully imported		BJ145 ball joint	SX1140	TE489L	TE489L			RE862					
			RH-BJ5203R LH-BJ5203L inc. arm											

H O V O H

STEERING and SUSPENSION COMPONENTS



YEAR	MODEL	BALL JOINT UPPER 	BALL JOINT LOWER / KING PIN SET 	IDLER 	TIE ROD END L/H OUTER 	TIE ROD END R/H OUTER 	TIE ROD END L/H INNER 	TIE ROD END R/H INNER 	RACK END 	SIDE ROD 	CENTRE ROD 	DRAG LINK 	PITMAN 	NOTES/OTHER
8/81-12/84	Corolla AE71,KE70		BJ145		TE3676R	TE3676R			RE862 162mm long					female thread tie rod ends CARL!
5/83-5/85	Corolla AE86 - manual steer		BJ145		TE3676R 14mm thread	TE3676R 14mm thread				RH-TR645R LH-TR645L				RE863 - suits imported model only
5/83-5/85	Corolla AE86 - power steer		BJ145		TE3676R	TE3676R			RE864 imported 317mm long	RH-TR646R LH-TR646L				RE864 - suits imported model only
9/84-12/88	Corolla AE80,AE82 - manual steer Seca & Sprinter		BJ233 ball joint RH-BJ5207R LH-BJ5207L inc arm		TE648 85mm long	TE648 85mm long			RE865 328mm long					
9/84-12/88	Corolla AE80,AE82 - power steer Seca & Sprinter		BJ233 ball joint RH-BJ5207R LH-BJ5207L inc arm		TE648 85mm long	TE648 85mm long			RE866 315mm long					
9/84-12/88	Corolla AE80,AE82 - TRW rack		BJ233 ball joint RH-BJ5207R LH-BJ5207L inc arm		TE648 85mm long	TE648 85mm long			P191005 377mm long					
1989-on	Corolla AE90, AE92, AE93 - manual steer TRW rack		RH-BJ270 LH-BJ271		TE648 85mm long	TE648 85mm long			P191008 m/steer or RE2800 p/steer					
1989-9/94	Corolla AE90,AE92 4WD - power steer		RH-BJ270 LH-BJ271		TE648 85mm long	TE648 85mm long			RE867					
1988-92	Corolla AE95 4WD wagon - manual steer		RH-BJ270 LH-BJ271		TE648 85mm long	TE648 85mm long			RE2800					

STEERING and SUSPENSION COMPONENTS



YEAR	MODEL	BALL JOINT UPPER	BALL JOINT LOWER / KING PIN SET	IDLER	TIE ROD END L/H OUTER	TIE ROD END R/H OUTER	TIE ROD END L/H INNER	TIE ROD END R/H INNER	RACK END	SIDE ROD	CENTRE ROD	DRAG LINK	PITMAN	NOTES/OTHER
------	-------	------------------	---------------------------------	-------	-----------------------	-----------------------	-----------------------	-----------------------	----------	----------	------------	-----------	--------	-------------

Toyota

1988-92	Corolla AE95 4WD wagon - power steer		RH-BJ270 LH-BJ271		TE648 85mm long	TE648 85mm long			RE867					
7/94-00	Corolla AE101,AE102 AE10#, CR10#, EE10# series		BJ302		TE648 85mm long	TE648 85mm long			RE991					
1995-00	Corolla AE111				TE647	TE648								
CORONA														
1960-64	Corona RT20,RT20L,RT26 & Tiara	BJ66			TE180L	TE180L								
1964-69	Corona RT40,RT46,RT51,RT56	BJ68	BJ69	SX1138 from ch# 360001	TE185L	TE185L	TE186R	TE186R		TR404			SX5210	Upper arm repair kit - SX1097A
1971	Corona RT61DK (Mark II)						TE3602R	TE3602R						
1968-73	Corona RT72	BJ2201	BJ2202		TE3603L	TE3603L	TE3602R	TE3602R						TE3602R - 130mm long with U bend in shank
1970-73	Corona RT80,RT81	BJ68	BJ69	SX1138	TE185L	TE185L	TE3602R	TE3602R		TR406			SX5211	Upper arm repair kit - SX1097A
1974-8/78	Corona RT104,RT118	BJ128	BJ129	SX1137	TE489L	TE489L	TE494R	TE493R		TR646R			SX5212	
8/78-1/82	Corona XT130,XT131,RT132,RT133		BJ145	SX1141	TE489L	TE489L	TE564R	TE564R		TR556			SX5241	
1/82-1987	Corona ST141/2,RT142 - manual steer		BJ145		TE640R	TE640R			RE878	TR640				
1/82-1987	Corona ST141/2,RT142 - power steer		BJ145		TE641R	TE641R			RE878	TR640				
1/83-8/84	Corona AT, CT, ST150		BJ233		TE649	TE649				TR674				
9/84-87	Corona AT, CT, ST150		BJ233		TE648	TE648								
9/84-87	Corona AT, CT, ST150		BJ260		TE648	TE648								
CORONA MKII (MX SERIES)														
1972-77	Corona MX10,MX13,MX22,MX23	BJ128	BJ129	SX4213	TE506L	TE506L	TE506R	TE506R					SX5214	
CRESSIDA														
12/79-80	Cressida MX32,MX36		BJ232	SX2290	TE489L	TE489L	TE650	TE650		TR642			SX1662	
9/80-84	Cressida MX62 sedan & wagon - manual steer		BJ232	SX2390 m/steer	TE489L	TE489L	TE651	TE651		TR643			SX1662	

STEERING and SUSPENSION COMPONENTS



YEAR	MODEL	BALL JOINT UPPER	BALL JOINT LOWER / KING PIN SET	IDLER	TIE ROD END L/H OUTER	TIE ROD END R/H OUTER	TIE ROD END L/H INNER	TIE ROD END R/H INNER	RACK END	SIDE ROD	CENTRE ROD	DRAG LINK	PITMAN	NOTES/OTHER
------	-------	------------------	---------------------------------	-------	-----------------------	-----------------------	-----------------------	-----------------------	----------	----------	------------	-----------	--------	-------------

TOYOTA

9/80-84	Cressida MX62 sedan & wagon - power steer		BJ232	SX2391 p/steer	TE489L	TE489L	TE651	TE651		TR643			SX1662	
8/84-8/88	Cressida MX73 sedan And early MX83 (in Australia)		BJ232		TE647	TE647				RH-RE882R LH-RE882L				
8/88-8/90	Cressida MX83		RH-BJ370 LH-BJ371 inc. arms		TE907	TE907				RH-RE912 LH-RE913				
8/90-on	Cressida													
	CROWN													
1964-8/67	Crown RS40,RS41,MS41,MS45,MS46	BJ66	BJ67		TE180L	TE180L								
9/67-71	Crown RS50,RS60,MS53,MS57,RS56,MS55	BJ114	BJ115	SX1129	TE180L	TE180L	TE3605R	TE3605R					SX9025	SX1129 - slight bend in arm
2/71-12/72	Crown MS65,MS67,MS70,MS75	BJ114	BJ115	SX1129	TE541L	TE541L	TE9316R	TE9316R					SX9075	SX1129 - slight bend in arm
1/73-9/74	Crown MS65,MS67,MS70,MS75	BJ114	BJ115	SX1129	TE541L	TE541L	TE9316R	TE9316R					SX0995	SX1129 - slight bend in arm
10/74-8/79	Crown MS83,MS85 - manual steer	BJ114	BJ162	SX1211	TE541L	TE541L	TE542R	TE542R					SX5217	SX1211 - straight arm
10/74-8/79	Crown MS83,MS85 - power steer	BJ114	BJ162	SX1129	TE541L	TE541L	TE542R	TE542R					SX5485	SX1129 - slight bend in arm
9/79-83	Crown MS111,MS112 - manual steer	BJ114	BJ162	SX1211	TE541L	TE541L	TE542R	TE542R		TR952			SX9175 or SX1228	SX1211 - straight arm In some cases SX9175 will not fit MS112 crown Check pitman arms prior to ordering!
9/79-83	Crown MS111,MS112 - power steer	BJ114	BJ162	SX1129	TE541L	TE541L	TE542R	TE542R		TR952			SX9175 or SX1228	SX1129 - slight bend in arm In some cases SX9175 will not fit MS112 crown Check pitman arms prior to ordering!
8/83-8/87	Crown MS123	BJ309	BJ310	SX1230	TE642L	TE642L	TE711R	TE711R		TR402			SX1228	
9/87-91	Crown MS13# series	BJ114	BJ162	SX1231	TE642L	TE642L	TE711R	TE711R					SX2580	
	ECHO													
all	Echo		BJ3602		TE9026L	TE9026R			RE3600					For Ball Joint inc. arm - use BJ9035L & BJ9035R
	LEXCEN													

STEERING and SUSPENSION COMPONENTS



YEAR	MODEL	BALL JOINT UPPER	BALL JOINT LOWER / KING PIN SET	IDLER	TIE ROD END L/H OUTER	TIE ROD END R/H OUTER	TIE ROD END L/H INNER	TIE ROD END R/H INNER	RACK END	SIDE ROD	CENTRE ROD	DRAG LINK	PITMAN	NOTES/OTHER
------	-------	------------------	---------------------------------	-------	-----------------------	-----------------------	-----------------------	-----------------------	----------	----------	------------	-----------	--------	-------------

10/88-10/91	Lexcen VN,VP - manual steer		BJ166 & BJ166OS (oversize)		TE738	TE738			P191012 (RE823/24)					
10/88-6/93	Lexcen VN,VP - power steer		BJ166 & BJ166OS (oversize)		TE738	TE738			P191012 (RE823/24)					
7/93-on	Lexcen VR,VS		RH-BJ300R LH-BJ300L		TE750	TE750			P191031 (RE951)					
	MR2													
6/84-89	MR2 AW10 AW11 sports coupe		BJ234 - front BJ231 - rear		TE649	TE649			RE2660					BJ231 - four wheel steer rear ball joints
12/89-94	MR2 SW20 sports coupe		BJ234 - front BJ231 - rear		TE4547	TE4546			RE4553					BJ231 - four wheel steer rear ball joints
	PASEO													
1/91-94	Paseo EL44		RH-BJ551R LH-BJ552L		TE2941	TE2941			RE2940					
1998-on	Paseo 1.5lt 2 door coupe													
	RAV4 - see TOYOTA - Commercial													
	SOARER													
2/81-86	GZ1#, MZ1#		BJ232						RE878	TR640				
1/86-4/91	GZ2#, MZ2#	BJ486	BJ435						RE879	TR3530				
5/91-on	JZZ3#, UZZ3#	BJ2946	RH-BJ6865 LH-BJ6965						RE9015	RH-LH-				
	SPRINTER COUPE													
1983-86	Sprinter Coupe AE86 1.6lt - manual steer		BJ145		TE803R	TE803R			RE862					
1983-86	Sprinter Coupe AE86 1.6lt - power steer		BJ145		TE803R	TE803R			RE868					
	STARLET													

STEERING and SUSPENSION COMPONENTS



YEAR	MODEL	BALL JOINT UPPER	BALL JOINT LOWER / KING PIN SET	IDLER	TIE ROD END L/H OUTER	TIE ROD END R/H OUTER	TIE ROD END L/H INNER	TIE ROD END R/H INNER	RACK END	SIDE ROD	CENTRE ROD	DRAG LINK	PITMAN	NOTES/OTHER
SUPRA														
1981-86	Supra MA61,SA63 - manual steer		BJ232		TE640R	TE640R			RE878					
1981-86	Supra MA61,SA63 - power steer		BJ232		TE641R	TE641R			RE878					
2/86-4/93	Supra MA70		BJ360		TE3686R	TE3686R			RE878 or RE879					RE878 - 14x1.5 threads 190mm RE879 - 14x1.5 threads 240mm
2/86-4/93	Supra MA71		BJ360		TE3686R	TE3686R			RE995					
T18 - see COROLLA														
TERCEL														
5/82-1/88	Tercel Wagon AL20,AL25 - manual steer		BJ234		TE3645L	TE3645R			RE868	RH-TR645R LH-TR645L				Tie rod ends - same as side rods - 275mm long
5/82-1/88	Tercel Wagon AL20,AL25 - power steer		BJ234		TE3646L	TE3646R			RE868	RH-TR646R LH-TR646L				Tie rod ends - same as side rods - 265mm long
2/88-90	Tercel		BJ2702		TE648	TE648								
1991-99	Tercel		RH-BJ2942R LH-BJ2942L		TE2942	TE2942								
VIENTA - see CAMRY														
TOYOTA - Commercial														
BLIZZARD														
1982-84	Blizzard LD10				TE712	TE600R								TE712 - LH thread
1984-on	Blizzard LD20, LD21									TR647				
BUNDERA (refer Illustrations)														
1985-91	Bundera RJ0,LJ70 4 cyl petrol & diesel turbo				TE698L	TE631R	TE699R	TE700L						4 piece repair kit - TE697R - E
COASTER														

**T
o
y
o
t
a
-**

STEERING and SUSPENSION COMPONENTS



YEAR	MODEL	BALL JOINT UPPER	BALL JOINT LOWER / KING PIN SET	IDLER	TIE ROD END L/H OUTER	TIE ROD END R/H OUTER	TIE ROD END L/H INNER	TIE ROD END R/H INNER	RACK END	SIDE ROD	CENTRE ROD	DRAG LINK	PITMAN	NOTES/OTHER
------	-------	------------------	---------------------------------	-------	-----------------------	-----------------------	-----------------------	-----------------------	----------	----------	------------	-----------	--------	-------------

Commercial - Toyota

10/69-72	Coaster RU1#, JU1#, BU1#, BB1#, RB1#		KX247		TE654L	TE654R								King pin set - 25mm x 154mm
2/72-79	Coaster RU1#, JU1#, BU1#, BB1#, RB1#		KX247		TE598L	TE597R								King pin set - 25mm x 154mm
1979-82	Coaster RU1#, JU1#, BU1#, BB1#, RB1#, BU61		KX261		TE598L	TE597R								King pin set - 28mm x 159mm
5/82-93	Coaster RB2#, BB2#, BB3#, HB3#, HZB3#, HDB20, HDB30#	BJ263	RH-BJ8068 LH-BJ8069	SX2490	TE655L	TE655L	TE656	TE656		TR9175	TR9185	TR2490		
1/93-on	Coaster BB4#, HDB5#, HZB4#, HZB5#	BJ9095	RH-BJ9015 LH-BJ9018	SX2490	TE3551	TE3551	TE656	TE656		TR3550	TR9215	TR9105		
	DA SERIES													
1962-on	DA100, DA115, FA90, FA100		KX415											
1969-84	DA115 truck, DR10, DR15bus 6ton		KX263		TE389L	TE389R								King pin set - 40mm x 216mm
	DYNA													
up to 1969	Dyna RK150, RK106, RK170 series		KX246		TE598L	TE597R								
1969-72	Dyna RU10,RU12,RU15 - 2000/2500kg		KX247		TE467L	TE467R								King pin set - 25mm x 154mm
1972-78	Dyna RU10/12/15/20/30,BU10/20/32/36, HU10/15/30/40/50		KX247		TE598L	TE597R								King pin set - 25mm x 154mm
1978-83	Dyna RU10/12/15/20/30,BU10/20/32/36, HU10/15/30/40/50		KX262		TE598L	TE597R								King pin set - 28mm x 160mm
1984	Dyna BU40, BU50		KX430											King pin set - 35mm x 205.5mm
1984-87	Dyna BU60		KX428		TE655L	TE655R								King pin set - 28mm x 160mm
84-8/87	Dyna BU77,BU85,BU88,BU93,BU98		KX428		TE598L	TE597R								King pin set - 28mm x 160mm with 2 roller bearings
84-8/87	Dyna WU90, BU90/95, HU40		KX431		TE655L male end or TE7655L female end	TE655R male end or TE7655R female end								Please note: it has been identified that some vehicles in this model range were fitted with female tie rod ends. Please check prior to ordering
1985-on	Dyna YU60/62, BU61/65		KX428		TE655L male end or TE7655L	TE655R male end or TE7655R								Please note: it has been identified that some vehicles in this model range were fitted with female tie rod ends. Please check prior to ordering

STEERING and SUSPENSION COMPONENTS



YEAR	MODEL	BALL JOINT UPPER	BALL JOINT LOWER / KING PIN SET	IDLER	TIE ROD END L/H OUTER	TIE ROD END R/H OUTER	TIE ROD END L/H INNER	TIE ROD END R/H INNER	RACK END	SIDE ROD	CENTRE ROD	DRAG LINK	PITMAN	NOTES/OTHER
------	-------	------------------	---------------------------------	-------	-----------------------	-----------------------	-----------------------	-----------------------	----------	----------	------------	-----------	--------	-------------

					female end	female end								
8/85-87	Dyna LY60/61		KX426		TE598L	TE597R								
1987-on	Dyna LY60/61		KX428		TE598L	TE597R								
8/85-on	Dyna 100 YH80,LH80 - truck	BJ236	BJ237	SX2790	TE540L	TE540L	TE643R	TE643R		TR2481	TR9165	TR9195		
4 RUNNER														
1983-88	LN60,YN60	not required	not required		TE3674R	TE658						**		** Drag link repair kit - TE442K suits some models
1985-89	LN61,YN63	BJ264	BJ265	SX1215	TE540L	TE540L	TE702R	TE702R				**	SX1216	** Drag link repair kit - TE442K suits some models
1989-8/91	RN130,RN135,YN130,YN135,LN130,LN135, VZN130 with independent front suspension (inc. Surf)	BJ500	BJ503	SX1215	TE540L	TE540L	TE702R	TE702R				**	SX1216	** Drag link repair kit - TE442K suits some models
8/91-1995	RN130,RN135,YN130,YN135,LN130,LN135, VZN130 with independent front suspension (inc. Surf)	BJ500	BJ503	SX9375	TE9385	TE9385	TE9185	TE9185				**	SX5250	** Drag link repair kit - TE442K suits some models



4 Runner
1985-89
IFS / Leaf Springs

Front Spring Rear Pin	Front Spring Front Shackle L/H	Front Spring Front Shackle R/H	Rear Spring Front Pin	Rear Spring Rear Shackle L/H	Rear Spring Rear Shackle R/H
			PK385	SK386	SK386

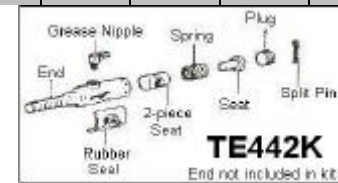

Shackle & Pin Kits

HIACE - Van, Wagon & Commuter (also see HIACE - Truck)														
9/67-1/71	Hiace PH10,RH15 - van, wagon, commuter	BJ66	BJ67#		TE450L 12mm x 1.25mm ball bolt thread	TE450R				RH-TR211R LH-TR211L		DL402 some models		BJ67 - 14mm ball bolt thread - use '555' brand only DL402 - check before ordering
2/71-1/72	Hiace PH1#, RH10, RH11 - van, wagon, commuter	BJ66	BJ67# (14mm)	SX4218	TE484L 14mm x 1.25mm ball bolt thread	TE484R				RH-TR648R LH-TR648L		DL402		BJ67 - 14mm ball bolt thread - use '555' brand only
2/72-11/75	Hiace PH1#, RH10, RH16 - van, wagon, commuter	BJ66	BJ127 (16mm)	SX1160	TE484L	TE484L	TE485R	TE485R		TR649	TR2110	DL402		SX1160 - 2 bolt mount BJ127 - 16mm ball bolt thread
12/75-1/77	Hiace PH1#, RH10, RH16 - van, wagon, commuter	BJ66	BJ127	SX1160	TE484L	TE484L	TE485R	TE485R		TR649	TR2111	DL402		SX1160 - 2 bolt mount
2/77-11/82	Hiace RH11, RH2#, RH3#, RH4# - van, wagon, commuter	BJ66	BJ127	SX1160	TE484L	TE484L	TE485R	TE485R		TR649	TR2180	DL402		SX1160 - 2 bolt mount
2/77-11/82	Hiace LH11, LH2#, LH3# - van, wagon, commuter	BJ66	BJ127	SX1160	TE484L	TE484L	TE485R	TE485R		TR649	TR2180	DL402		SX4260 - 3 bolt mount
12/82-8/85	Hiace LH50, LH60, LH70 - van and commuter	BJ236	BJ237	SX4260	TE540L	TE540L	TE643R	TE643R		TR451	TR500	TR501		SX4260 - 3 bolt mount
12/82-8/85	Hiace LH50, LH60, LH70 - wagon	BJ236	BJ237	SX4260	TE540L	TE540L	TE643R	TE643R		TR451	TR4505	TR501		SX4260 - 3 bolt mount

STEERING and SUSPENSION COMPONENTS



YEAR	MODEL	BALL JOINT UPPER	BALL JOINT LOWER / KING PIN SET	IDLER	TIE ROD END L/H OUTER	TIE ROD END R/H OUTER	TIE ROD END L/H INNER	TIE ROD END R/H INNER	RACK END	SIDE ROD	CENTRE ROD	DRAG LINK	PITMAN	NOTES/OTHER
------	-------	------------------	---------------------------------	-------	-----------------------	-----------------------	-----------------------	-----------------------	----------	----------	------------	-----------	--------	-------------

**CO
E
R
E
-
a
-
i**

12/82-8/85	Hiace YH5#, YH6#, YH7# - van and commuter	BJ236	BJ237	SX4260	TE540L	TE540L	TE643R	TE643R		TR451	TR500	TR501		SX4260 - 3 bolt mount
12/82-8/85	Hiace YH5#, YH6#, YH7# - wagon	BJ236	BJ237	SX4260	TE540L	TE540L	TE643R	TE643R		TR451	TR4505	TR501		SX4260 - 3 bolt mount
9/85-7/89	Hiace LH51, LH61, LH71 - van and commuter	BJ236	BJ237	SX4260	TE540L	TE540L	TE643R	TE643R		TR2481	TR500	TR501		SX4260 - 3 bolt mount
9/85-7/89	Hiace LH51, LH61, LH71 - wagon	BJ236	BJ237	SX4260	TE540L	TE540L	TE643R	TE643R		TR2481	TR4505	TR501		SX4260 - 3 bolt mount
9/85-7/89	Hiace YH5#, YH6#, YH7# - van and commuter	BJ236	BJ237	SX4260	TE540L	TE540L	TE643R	TE643R		TR2481	TR500	TR501		SX4260 - 3 bolt mount
9/85-7/89	Hiace YH5#, YH6#, YH7# - wagon	BJ236	BJ237	SX4260	TE540L	TE540L	TE643R	TE643R		TR2481	TR4505	TR501		SX4260 - 3 bolt mount
8/89-7/93	Hiace KZH100/110/120 - van, wagon, commuter	BJ837	BJ237		TE994	TE994			RE998					
8/89-7/93	Hiace LH100/102/103/110/113/115/120/123/125/140 - van, wagon, commuter	BJ837	BJ237		TE994	TE994			RE998					
8/89-7/93	Hiace RZH10#, RZH11#, RZH12# - van, wagon, commu	BJ837	BJ237		TE994	TE994			RE998					
8/93-on	Hiace KZH100/110/120 - van, wagon, commuter	BJ837	BJ237		TE994	TE994			RE998					
8/93-on	Hiace LH100/102/103/110/113/115/120/123/125/140 - van, wagon, commuter	BJ837	BJ237		TE994	TE994			RE998					
8/93-7/95	Hiace RZH10#, RZH11#, RZH12# - van, wagon, commu	BJ837	BJ237		TE994	TE994			RE998					
8/95-on	Hiace LH103/113/125, RZH103/113/125 - manual steer	BJ8066 RH inc. arm BJ8067 LH inc. arm	BJ553						RE9505					
8/95-on	Hiace LH103/113/125, RZH103/113/125 - power steer	BJ8066 RH inc. arm BJ8067 LH inc. arm	BJ553		TE9325	TE9325			RE9565					
8/95-on	Hiace LH110, 11#, 12#, 16#, 17#, 18# KZH10#, 11#, 126, 13# RZH10#, 11#, 12#, 133	BJ8066 RH inc. arm BJ8067 LH inc. arm	BJ553		TE9325	TE9325			RE9565					

STEERING and SUSPENSION COMPONENTS

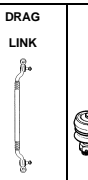
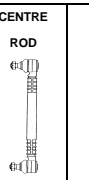
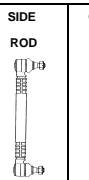
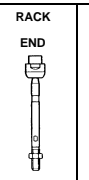
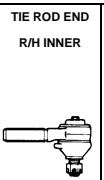
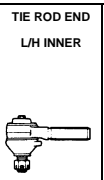
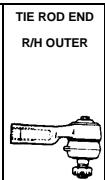
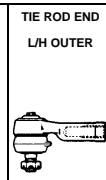
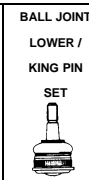

YEAR	MODEL	BALL JOINT UPPER	BALL JOINT LOWER / KING PIN SET	IDLER	TIE ROD END L/H OUTER	TIE ROD END R/H OUTER	TIE ROD END L/H INNER	TIE ROD END R/H INNER	RACK END	SIDE ROD	CENTRE ROD	DRAG LINK	PITMAN	NOTES/OTHER
------	-------	------------------	---------------------------------	-------	-----------------------	-----------------------	-----------------------	-----------------------	----------	----------	------------	-----------	--------	-------------

YEAR	MODEL	BALL JOINT UPPER	BALL JOINT LOWER / KING PIN SET	IDLER	TIE ROD END L/H OUTER	TIE ROD END R/H OUTER	TIE ROD END L/H INNER	TIE ROD END R/H INNER	RACK END	SIDE ROD	CENTRE ROD	DRAG LINK	PITMAN	NOTES/OTHER
10/79-9/81	HILUX 4WD Hilux RN36 4WD			SA3570 Strg Knuckle Arm	TE3671R	TE540L				TR2400	Seal End not included in kit	TE442K		TE442K - Drag link repair kit (2 per drag link)
10/81-10/83	Hilux RN38/39/48, LN36/46 4WD	not required	not required	SA3570 Strg Knuckle Arm	TE3672R 17mm thread	TE540L				TR2401		TE442K		TE442K - Drag link repair kit (2 per drag link)
11/83-88	Hilux LN60, LN65, YN60, YN62, YN65, YN67 4WD	not required	not required	SA3570 Strg Knuckle Arm	TE3674R 21mm thread	TE658 90mm long or TE658L 100mm long				TR652		TE442K Repair Kit or DL070 Drag Link	SX5312	TR652 - consists of TE658/TE659/990mm long tube TE3674R - has provision for steering damper TE442K - Drag link repair kit (2 per drag link)
8/85-88	Hilux YN61/63, LN61/66, RN61/66, YZN61, VZN66 4WD with independent front suspension	BJ264	BJ265	SX1215	TE540L	TE540L	TE702R	TE702R		TR2720		DL070	SX1216	TE442K - Drag link repair kit (2 per drag link)
8/88-3/90	Hilux RN105, LN105/106, YN106 4WD	not required	not required	SA3570 Strg Knuckle Arm	TE3674R 21mm thread	TE658 90mm long or TE658L 100mm long				TR652		TE442K Repair Kit or DL070 Drag Link	SX5160 m/steer up to 8/90	TR652 - consists of TE658/TE659/990mm long tube TE3674R - has provision for steering damper TE442K - Drag link repair kit (2 per drag link)
4/90-on	Hilux RN105, LN105/106, YN106 4WD	not required	not required	SA3570 Strg Knuckle Arm	TE2842	TE2841				TR2840		TE442K Repair Kit or DL070 Drag Link	SX5140 8/90-on	TE442K - Drag link repair kit (2 per drag link)
8/88-3/89	Hilux RN101/106/110/126/130 4WD with independent front suspension	BJ264 (BJ500)	BJ265	SX1215	TE540L	TE540L	TE702R	TE702R		TR2720		DL070	SX1216	TE442K - Drag link repair kit (2 per drag link)
8/88-3/89	Hilux LN107/111/130/135 4WD with independent front suspension	BJ264 (BJ500)	BJ265	SX1215	TE540L	TE540L	TE702R	TE702R		TR2720		DL070	SX1216	TE442K - Drag link repair kit (2 per drag link)
8/88-3/89	Hilux YN130/135, VZN100/105/110/130/131 4WD with independent front suspension	BJ264 (BJ500)	BJ265	SX1215	TE540L	TE540L	TE702R	TE702R		TR2720		DL070	SX1216	TE442K - Drag link repair kit (2 per drag link)
4/89-7/91	Hilux RN101/106/110/126/130 4WD with independent front suspension	BJ264 (BJ500)	BJ503	SX1312	TE540L	TE540L	TE702R	TE702R		TR2720		DL070	SX1216	TE442K - Drag link repair kit (2 per drag link)
4/89-7/91	Hilux LN107/111/130/135 4WD with independent front suspension	BJ264 (BJ500)	BJ503	SX1312	TE540L	TE540L	TE702R	TE702R		TR2720		DL070	SX1216	TE442K - Drag link repair kit (2 per drag link)
4/89-7/91	Hilux YN130/135, VZN100/105/110/130/131 4WD	BJ264	BJ503	SX1312	TE540L	TE540L	TE702R	TE702R		TR2720		DL070	SX1216	TE442K - Drag link repair kit (2 per drag link)

TOYOTA COERCION

STEERING and SUSPENSION COMPONENTS



YEAR	MODEL	BALL JOINT UPPER	BALL JOINT LOWER / KING PIN SET	IDLER	TIE ROD END L/H OUTER	TIE ROD END R/H OUTER	TIE ROD END L/H INNER	TIE ROD END R/H INNER	RACK END	SIDE ROD	CENTRE ROD	DRAG LINK	PITMAN	NOTES/OTHER
------	-------	------------------	---------------------------------	-------	-----------------------	-----------------------	-----------------------	-----------------------	----------	----------	------------	-----------	--------	-------------

	with independent front suspension	(BJ500)													
8/91-on	Hilux RN101/106/110/126/130 4WD with independent front suspension	BJ264 (BJ500)	BJ503	SX9375	TE540L	TE540L	TE702R	TE702R		TR2720		DL070 to 1998	SX5250 (SX2860)	TE442K - Drag link repair kit (2 per drag link)	
8/91-on	Hilux LN107/111/130/135 4WD with independent front suspension	BJ264 (BJ500)	BJ503	SX9375	TE540L	TE540L	TE702R	TE702R		TR2720		DL070 to 1998	SX5250 (SX2860)	TE442K - Drag link repair kit (2 per drag link)	
8/91-on	Hilux YN130/135, VZN100/105/110/130/131 4WD with independent front suspension	BJ264 (BJ500)	BJ503	SX9375	TE540L	TE540L	TE702R	TE702R		TR2720		DL070 to 1998	SX5250 (SX2860)	TE442K - Drag link repair kit (2 per drag link)	
4/89-on	Hilux LN107, LN13#, RN106, RN110, RN13#, VZV130				Steering Arm RH - use SX561										
8/97-on	Hilux KZN165, LN16#, LN17#, LN19#, RZN16#, RZN174, RZN19#				Steering Arm Ball Stud Only - use BS351										
8/97-on	Hilux KZN165, LN16#, LN17#, LN19#, RZN16#, RZN174	BJ500	BJ503	SX9445						TR2720		DL070 to 1998	SX5140		
1995-on	Hilux KZN185, RZN18#, VZN18#	BJ9016	RH-BJ3562R LH-BJ3562L		TE3561L	TE3561R									

	Hilux - all leaf front models	Front Spring Rear Pin PK385	Front Spring Front Shackle LH SK384	Front Spring Front Shackle R/H SK384	Rear Spring Front Pin PK385	Rear Spring Rear Shackle L/H SK386	Rear Spring Rear Shackle R/H SK386	Shackle & Pin Kits						
--	-------------------------------	-----------------------------------	--	---	-----------------------------------	---	---	--------------------	--	--	--	--	--	--

Hilux Steering Linkage Illustrations

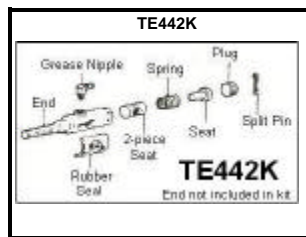
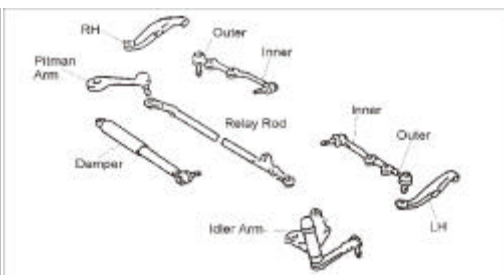
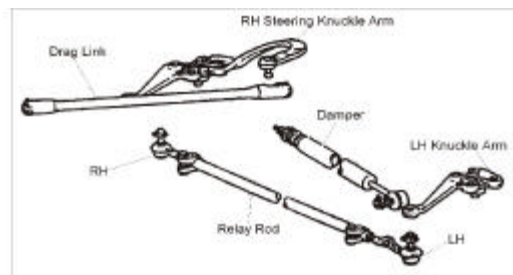

STEERING and SUSPENSION COMPONENTS

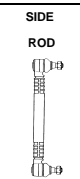
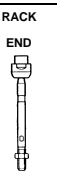
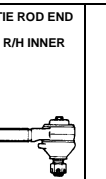
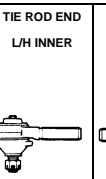
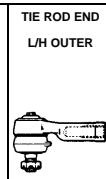
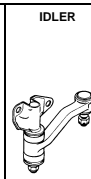
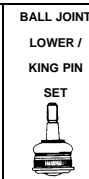

YEAR	MODEL	BALL JOINT UPPER	BALL JOINT LOWER / KING PIN SET	IDLER	TIE ROD END L/H OUTER	TIE ROD END R/H OUTER	TIE ROD END L/H INNER	TIE ROD END R/H INNER	RACK END	SIDE ROD	CENTRE ROD	DRAG LINK	PITMAN	NOTES/OTHER
------	-------	------------------	---------------------------------	-------	-----------------------	-----------------------	-----------------------	-----------------------	----------	----------	------------	-----------	--------	-------------

Hilux Leaf Spring Front
1/79 - 8/97

Hilux Independent Front
8/85 - on

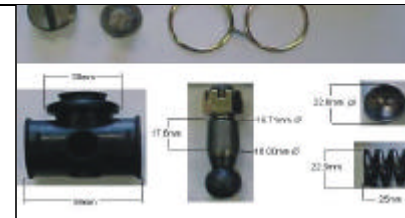

					"REAR" Tie Rod Ends		"FRONT" Relay Rod Ends							
					Left	Right	Left	Right						
LANDCRUISER 4 cylinder (refer Illustrations)														
2/74-84	Landcruiser BJ4#			SX5402	TE470L	TE469R	TE471L	TE471R		TR4520 Relay Rod	TR4620 Track Rod	TE472L end only		5 piece repair kit - TE660 - A
8/80-90	Landcruiser BJ6#				TE632L	TE631R	TE630R	TE629L					SX6090	4 piece repair kit - TE644 - C
11/84-90	Landcruiser BJ7#				TE632L	TE631R	TE630R	TE696L		TR4560 Relay Rod	TR4660 Track Rod	TE509K	SX6110	4 piece repair kit - TE695R - D
11/84-90	Landcruiser RJ70,LJ70,LJ71				TE698L	TE631R	TE699R	TE700L		TR4510 Relay Rod	TR4690 Track Rod		SX6110	4 piece repair kit - TE697R - E
1/90-on	Landcruiser LJ7#, KZJ7#				TE9127	TE997	TE990	TE9097					SX6110	
LANDCRUISER 6 cylinder petrol (refer Illustrations)														
1959-63	Landcruiser FJ40,FJ45				TE471R	TE471R	TE471R	TE471L				TE442K		TE442K - Drag Link Repair Kit
64-9/75	Landcruiser FJ4#			SX5402	TE470L	TE469R	TE471L	TE471R		TR4520 Relay Rod	TR4620 Track Rod	TE472L end only		5 piece repair kit - TE660 - A
3/69-7/80	Landcruiser FJ5#			SX5402	TE470L	TE469R	TE471L	TE471R		TR4531 Relay Rod	TR4620 Track Rod	TR9015 Drag Link		4 piece repair kit - TE661 - B
8/80-6/83	Landcruiser FJ6#				TE632L	TE631R	TE630R	TE629L		TR4545 Relay Rod		TE509K 11/84-on	SX6090	4 piece repair kit - TE644 - C TE509K - Drag link repair kit 11/84-on
6/83-1/90	Landcruiser FJ6#				TE632L	TE631R	TE630R	TE629L		TR4565 Relay Rod	TR4665 Track Rod	TE509K 11/84-on	SX6090	4 piece repair kit - TE644 - C TE509K - Drag link repair kit 11/84-on
11/84-90	Landcruiser FJ7#				TE632L	TE631R	TE630R	TE696L		TR4560 Relay Rod	TR4660 Track Rod	TE509K	SX6110	4 piece repair kit - TE695R - D
1/90-on	Landcruiser FJ75				TE2752	TE997	TE2754	TE2755		TR4560	TR4660	TE509K	SX6110	4 piece repair kit - TE2750R

TOYOTA - PROC

STEERING and SUSPENSION COMPONENTS



YEAR	MODEL	BALL JOINT UPPER	BALL JOINT LOWER / KING PIN SET	IDLER	TIE ROD END L/H OUTER	TIE ROD END R/H OUTER	TIE ROD END L/H INNER	TIE ROD END R/H INNER	RACK END	SIDE ROD	CENTRE ROD	DRAG LINK	PITMAN	NOTES/OTHER
------	-------	------------------	---------------------------------	-------	-----------------------	-----------------------	-----------------------	-----------------------	----------	----------	------------	-----------	--------	-------------

M
e
r
c
i
d
i
e

					160mm long LHT with hole	110mm long RH thread	134mm long RH thread	190mm long LHT with hole		Relay Rod	Track Rod			
8/99-on	Landcruiser FZJ78, FZJ79				TE997	TE995	TE2754	TE2755		TE4530 Relay Rod	TE4610 Track Rod	TE442K		TE442K - Drag Link Repair Kit
1/90-on	Landcruiser FJ80, FZJ80, HDJ181, HZJ181				TE995	TE997	TE990	TE989		TR4220 Relay Rod	TR4410 Track Rod		SX6200 to 1/95 SX6201 2/95-on	4 piece repair kit - TE2950K
1/98-on	Landcruiser FZJ105, HZJ105				TE995	TE997	TE990	TE989		TR4220 Relay Rod	TR4410 Track Rod		SX6201	4 piece repair kit - TE2950K
LANDCRUISER 6 cylinder diesel (refer Illustrations)														
1979-84	Landcruiser HJ45,HJ47			SX5402	TE470L	TE469R	TE471L	TE471R		TR4520 Relay Rod	TR4620 Track Rod	TE472L end only		5 piece repair kit - TE660 - A
8/80-6/83	Landcruiser HJ6#				TE632L	TE631R	TE630R	TE629L		TR4545 Relay Rod		TE509K 11/84-on	SX6090	4 piece repair kit - TE644 - C TE509K - Drag link repair kit 11/84-on
6/83-1/90	Landcruiser HJ6#				TE632L	TE631R	TE630R	TE629L		TR4565 Relay Rod	TR4665 Track Rod	TE509K 11/84-on	SX6090	4 piece repair kit - TE644 - C TE509K - Drag link repair kit 11/84-on
11/84-90	Landcruiser HJ75				TE632L	TE631R	TE630R	TE696L		TR4560 Relay Rod	TR4660 Track Rod	TE509K	SX6110	4 piece repair kit - TE695R - D

T
o
y
o
t
a
-
C
o

					"REAR" Tie Rod Ends		"FRONT" Relay Rod Ends							
					Left	Right	Left	Right						
1/90-on	Landcruiser HZJ7# (not including 78), PZJ7#				TE2752 160mm long LHT with hole	TE997 110mm long RH thread	TE2754 134mm long RH thread	TE2755 190mm long LHT with hole		TR4560 Relay Rod	TR4660 Track Rod	TE509K	SX6110	4 piece repair kit - TE2750R
8/99-on	Landcruiser HZJ78, HZJ79				TE997	TE995	TE2754	TE2755		TE4530 Relay Rod	TE4610 Track Rod	TE442K		TE442K - Drag Link Repair Kit
1/90-on	Landcruiser HZJ80, HDJ80, HZJ81, HDJ81, HZJ105				TE995	TE997	TE990	TE989		TR4220 Relay Rod	TR4410 Track Rod		SX6200 to 1/95 SX6201 2/95-on	4 piece repair kit - TE2950K

STEERING and SUSPENSION COMPONENTS



BALL JOINT UPPER	BALL JOINT LOWER / KING PIN SET	IDLER	TIE ROD END L/H OUTER	TIE ROD END R/H OUTER	TIE ROD END L/H INNER	TIE ROD END R/H INNER	RACK END	SIDE ROD	CENTRE ROD	DRAG LINK	PITMAN	NOTES/OTHER



YEAR	MODEL											
------	-------	--	--	--	--	--	--	--	--	--	--	--

1996-on	Landcruiser KZJ9#, RZJ9#, VZJ9#	BJ9016	RH-BJ3562R LH-BJ3562L		TE1561L	TE1561R						
---------	---------------------------------	--------	--------------------------	--	---------	---------	--	--	--	--	--	--

PRADO - see Prado

Landcruiser Steering Linkage Illustrations

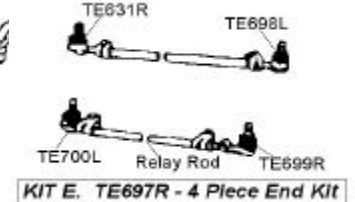
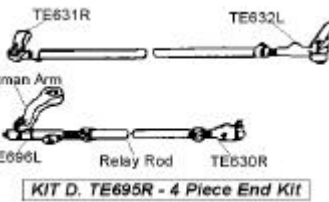
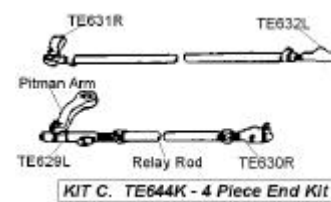
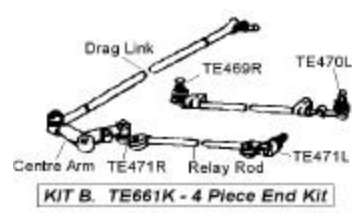
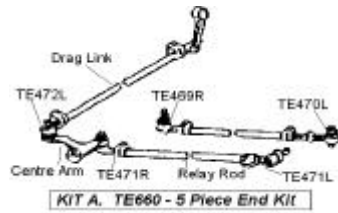

		Front Spring Rear Pin	Front Spring Front Shackle L/H	Front Spring Front Shackle R/H	Rear Spring Front Pin	Rear Spring Rear Shackle L/H	Rear Spring Rear Shackle R/H
pre-1980	Landcruiser 40 series - 25mm eyes	PK346	SK343	SK343	PK346	SK343	SK343
pre-1980	Landcruiser 45 series - 25mm eyes	PK346	SK343	SK343	PK347	SK345	SK344
1980-on	Landcruiser 40-42 series - 35mm eyes	PK351	SK348L	SK348R	PK351	SK348L	SK348R
1980-on	Landcruiser 45-47 series - 35mm eyes	PK351	SK348L	SK348R	PK351	SK349L	SK350R
	Landcruiser 60 series	PK351	SK348L	SK348R	PK351	SK352	SK352
	Landcruiser 75 series	PK351	SK348L	SK348R	PK354	SK353	SK353

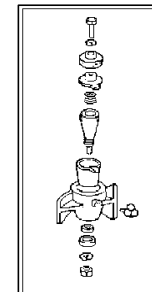

SX5402

Landcruiser Centre Arm Kit

(Note: Bracket not included in kit)

OE# 04453-60020/21

(OE# quoted for reference purposes only. E.& O.E.)

LEXUS - see LEXUS

LITEACE - 2WD

11/70-9/79	Liteace KM1#	BJ68	BJ69	SX1222	TE663L	TE663R				RH-TR653R LH-TR653L	TR2240		Upper arm repair kit - SX1097A
10/79-9/81	Liteace KM20, TM20	BJ173	BJ129	SX4262 2 bolt mount	TE428L	TE428L	TE564R	TE564R		TR460	TR2380		
10/81-9/82	Liteace KM20, TM20	BJ173	BJ129	SX4262	TE428L	TE428L	TE838R	TE838R		TR461	TR2380		

STEERING and SUSPENSION COMPONENTS

Commercial

Toyota



YEAR	MODEL	BALL JOINT UPPER	BALL JOINT LOWER / KING PIN SET	IDLER	TIE ROD END L/H OUTER	TIE ROD END R/H OUTER	TIE ROD END L/H INNER	TIE ROD END R/H INNER	RACK END	SIDE ROD	CENTRE ROD	DRAG LINK	PITMAN	NOTES/OTHER
------	-------	------------------	---------------------------------	-------	-----------------------	-----------------------	-----------------------	-----------------------	----------	----------	------------	-----------	--------	-------------

Commercial

				2 bolt mount										
10/82-8/85	Liteace YM20, YM21, CM20	BJ173	BJ225	SX4261 3 bolt mount	TE489L	TE489L	TE838R	TE838R		TR462			TR2381	
9/85-7/88	Liteace KM3#, CM3#, YM30 - manual steer	BJ173	BJ225		TE3675R	TE3675R			RE883	TR675				
9/85-7/88	Liteace KM3#, CM3#, YM30 - power steer	BJ173	BJ225		TE3675R	TE3675R			RE878	TR675				
8/88-92	Liteace KM3#, CM3#, YM3# - manual steer	BJ173	BJ225		TE992	TE992			RE996					
8/88-92	Liteace KM3#, CM3#, YM3# - power steer	BJ173	BJ225		TE992	TE992			RE9225					
1992-on	Liteace YR21, KR42 - manual steer	BJ173	BJ225		TE992	TE992			RE675					manual steer
1992-on	Liteace YR21, KR42 - power steer	BJ173	BJ225		TE992	TE992			RE395					power steer
LITEACE - 4WD														
9/85-7/88	Liteace CM4#, YM40 4WD & 4WD truck		BJ433		TE3688	TE3688			RE9085	TR929				
8/88-92	Liteace CM4#, YM40 4WD & 4WD truck		BJ433		TE5046	TE5046			RE9235					
LITEACE - Truck														
11/82-9/86	Liteace KM2#, YM2#, CM2#, TM20 - truck	BJ173	BJ225		TE189L	TE189L	TE838R	TE383R		TR462			TR2381	
10/86-6/88	Liteace KM5#, YM55, CM5# - truck - manual steer	BJ173	BJ225		TE3675R	TE3675R			RE883					
10/86-6/88	Liteace KM5#, YM55, CM5# - truck - power steer	BJ173	BJ225		TE3675R	TE3675R			RE878					
7/88-on	Liteace KM5#, YM55, CM5# - truck - manual steer	BJ173	BJ225		TE992	TE992			RE996					
7/88-on	Liteace KM5#, YM55, CM5# - truck - power steer	BJ173	BJ225		TE992	TE992			RE9225					
PRADO														
4/96-on	Prado	BJ9016	RH-BJ3562R LH-BJ3562L		TE3561L	TE3561R			RE9075					
RAV 4														

T

STEERING and SUSPENSION COMPONENTS



YEAR	MODEL	BALL JOINT UPPER	BALL JOINT LOWER / KING PIN SET	IDLER	TIE ROD END L/H OUTER	TIE ROD END R/H OUTER	TIE ROD END L/H INNER	TIE ROD END R/H INNER	RACK END	SIDE ROD	CENTRE ROD	DRAG LINK	PITMAN	NOTES/OTHER
------	-------	------------------	---------------------------------	-------	-----------------------	-----------------------	-----------------------	-----------------------	----------	----------	------------	-----------	--------	-------------

TOYOTA - COERCIA

1994-00	Rav 4 (SXA10)		BJ9025 ball joint only or RH-BJ2063 LH-BJ2064 inc. arm		TE9305	TE9305			RE9365					
2001-02	Rav 4		BJ9115		TE9095L	TE9095R			RE9055					
	SPACIA													
	Spacia	BJ173	BJ225											
	STOUT													
1965-72	Stout RK43 with Coil Front Suspension		BJ67#											BJ67 - 14mm ball bolt thread - use '555' brand only
1965-72	Stout RK40,RK41,RK43,RK45,RK27		KX245		TE180L (79mm)	TE180L (79mm)								King pin set - 0.825" x 5.000"
9/67-72	Stout RK101,RK110,RK111		KX245		TE180L (79mm)	TE466R (79mm)						TE442K		King pin set - 0.825" x 5.000" TE442K - Drag link repair kit
3/72-8/73	Stout RK101,RK110,RK111		KX245		TE484L (151mm)	TE484R (151mm)						TE442K		King pin set - 0.825" x 5.000" TE442K - Drag link repair kit
9/73-2/79	Stout RK101,RK110,RK111		KX245		TE627L	TE627R						TE442K		King pin set - 0.825" x 5.000" TE442K - Drag link repair kit
3/79-86	Stout RK110, YK110, PY20, LY		KX426		TE627L	TE627R						TE442K		King pin set - 25mm x 153.5mm TE442K - Drag link repair kit
	TACOMA													
1995-02	Tacoma 2WD	RH-BJ4339R LH-BJ4339L	RH-BJ4333R LH-BJ4333L		TE3541	TE3541			RE3908 m/steer RE3541 p/steer					
1995-00	Tacoma 4WD	BJ3561	RH-BJ1356R LH-BJ1356L		TE1356L	TE1356R			RE3561					
2001-02	Tacoma 4WD	BJ3561	RH-BJ1366R LH-BJ1366L		TE1356L	TE1356R			RE3561					

STEERING and SUSPENSION COMPONENTS



YEAR	MODEL	BALL JOINT UPPER	BALL JOINT LOWER / KING PIN SET	IDLER	TIE ROD END L/H OUTER	TIE ROD END R/H OUTER	TIE ROD END L/H INNER	TIE ROD END R/H INNER	RACK END	SIDE ROD	CENTRE ROD	DRAG LINK	PITMAN	NOTES/OTHER
------	-------	------------------	---------------------------------	-------	-----------------------	-----------------------	-----------------------	-----------------------	----------	----------	------------	-----------	--------	-------------

T o y o t a - C o m m e r c i a l

	TARAGO													
10/76-10/82	Tarago KR1#, TR1#	BJ2281	BJ2282	SX2280	TE489L	TE489L	TE564R	TE564R						SX5280
11/82-7/85	Tarago YR2#, CR2#	BJ173	BJ225	SX1164	TE489L	TE489L	TE639R	TE639R						
9/85-7/88	Tarago YR2#, CR2# 2WD - manual steer	BJ173	BJ225		TE3675R	TE3675R			RE883					
9/85-7/88	Tarago YR2#, CR2# 2WD - power steer	BJ173	BJ225		TE3675R	TE3675R			RE878					
8/88-on	Tarago YR2#, CR2# 2WD - manual steer	BJ173	BJ225		TE992	TE992			RE996					
8/88-on	Tarago YR2#, CR2# 2WD - power steer	BJ173	BJ225		TE992	TE992			RE9225					
1986-9/90	Tarago YR31 2WD				TE993	TE993			RE997					
1986-9/90	Tarago YR31 4WD				TE3688	TE3688			RE997					
8/85-on	Tarago TR3#, CR3# 4WD		BJ433						RE9085	TR989				
8/88-on	Tarago TR3#, CR3# 4WD		BJ433		TE5046	TE5046			RE9235					
5/90-on	Tarago		BJ333						RE29295 p/steer					
	TOWNACE													
1992-on	Townace YR39 - manual steer	BJ173	BJ225		TE992	TE992			RE675					manual steer
1992-on	Townace YR39 - power steer	BJ173	BJ225		TE992	TE992			RE395					power steer
	TOWNACE - Truck													
8/78-82	Townace RR1#, RR2# - truck	BJ2281	BJ2282		TE489L	TE489L	TE564R	TE564R						
11/82-9/86	Townace KM2#, YM2#, CM2#, TM20 - truck	BJ173	BJ225		TE189L	TE189L	TE838R	TE383R		TR462		TR2381		
10/86-6/88	Townace KM5#, YM55, CM5# - truck - manual steer	BJ173	BJ225		TE3675R	TE3675R			RE883					
10/86-6/88	Townace KM5#, YM55, CM5# - truck - power steer	BJ173	BJ225		TE3675R	TE3675R			RE878					
7/88-on	Townace KM5#, YM55, CM5# - truck - manual steer	BJ173	BJ225		TE992	TE992			RE996					

STEERING and SUSPENSION COMPONENTS



YEAR	MODEL	BALL JOINT UPPER	BALL JOINT LOWER / KING PIN SET	IDLER	TIE ROD END L/H OUTER	TIE ROD END R/H OUTER	TIE ROD END L/H INNER	TIE ROD END R/H INNER	RACK END	SIDE ROD	CENTRE ROD	DRAG LINK	PITMAN	NOTES/OTHER
7/88-on	Townace KM5#, YM55, CM5# - truck - power steer	BJ173	BJ225		TE992	TE992			RE9225					
	TOYO ACE													
67-9/71	Toyoace PK32,PK41,PK42 1-1.5ton		KX245		TE180L	TE180L								King pin set - 0.825" x 5.000"
9/71-73	Toyoace PY,RY10,RY12,RY14		KX245		TE484L	TE484R								King pin set - 0.825" x 5.000"
1974-85	Toyoace RY16,RY31,LY30,LY31		KX247		TE598L	TE597R								King pin set - 0.825" x 5.000"
TRIUMPH														
1959-74	Herald Coupe, Saloon, 1299, 12-50, 13-60, Courier Van, GT6 Mkl,II,III spitfire Mkl,II,III,IV, Vitesse 1600, 2000 Mkl,II	BJ46			TE167R	TE167R								
1962-67	TR4, TR5, TR5A	BJ5100												
1975-81	TR7		BJ718		TE1556	TE1556								
1964-78	2000 Mk I,II 2.5 PI, 2500 TC - manual steer		BJ112		TE429R	TE429R								manual steer
1964-78	2000 Mk I,II 2.5 PI, 2500 TC - power steer		BJ112		TE527R	TE527R								power steer
1971-78	Stag - all models - manual steer		BJ112		TE429R	TE429R								manual steer
1971-78	Stag - all models - power steer		BJ112		TE527R	TE527R								power steer
1971-81	Dolomite, Sprint	BJ659	RH-BJ660R LH-BJ660L		TE1572	TE1572								
VALIANT - see CHRYSLER														
VANGUARD														
1956-64	Vanguard		SX69											SX69 - lower knuckle support
VAUXHALL														
1955-58	Wyvern, Velox	BJ24	BJ23		TE125L	TE125R	TE125R	TE125L						
1963-75	Viva HA,HB,HC	BJ42	BJ57		TE179R	TE179R								
1967-72	Victor 1600,2000,FD series	BJ42	BJ57		TE179R	TE179R								

STEERING and SUSPENSION COMPONENTS

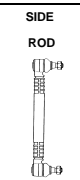
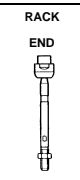
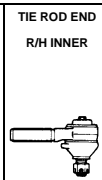
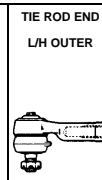
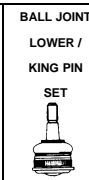

YEAR	MODEL	BALL JOINT UPPER	BALL JOINT LOWER / KING PIN SET	IDLER	TIE ROD END L/H OUTER	TIE ROD END R/H OUTER	TIE ROD END L/H INNER	TIE ROD END R/H INNER	RACK END	SIDE ROD	CENTRE ROD	DRAG LINK	PITMAN	NOTES/OTHER
------	-------	------------------	---------------------------------	-------	-----------------------	-----------------------	-----------------------	-----------------------	----------	----------	------------	-----------	--------	-------------

VOLKSWAGEN															
Volkswagen	BEETLE														
	1947-4/68	Type I - 1200,1300,1500,1600		KX161		TE132R RH thread	TE132L LH thread	TE133L LH thread	TE133R RH thread Angled 10.7 BLD						King pin set - 0.709" x 3.980" Linkpin bush kit - SX051A TE133L - with steering damper hole & 10.7mm top of taper diameter
			Note: when fitting KX161 the Link Pins must be removed. For replacement Link Pin Bush Kit - use SX051A												
	5/68-77	Type I - 1200,1300,1500,1600	BJ131	BJ132		TE495R RH thread	TE497L LH thread	TE496L LH thread	TE496R RH thread Angled 12.7 BLD						TE496R - 12.7mm top of taper diameter TE496L - with steering damper hole & 12.7mm top of taper diameter
	1970-73	Beetle 1600L,1600S,Super Bug		BJ133		TE495R RH thread	TE495R RH thread	TE497L LH thread	TE497L LH thread						TIE ROD END SELECTION Inner & Outer Tie Rod End Selection: NOTE - there is a threaded connecting tube for inner & outer tie rod ends - if this is reversed the tie rod end threads will appear to be incorrect. Please ensure the connecting tubes are in the correct orientation prior to selecting tie rod ends.
	1973-on	Beetle 1600L,1600S,Super Bug		BJ134		TE495R RH thread	TE495R RH thread	TE497L LH thread	TE497L LH thread						
	1998-on	New Beetle		RH-BJ7366R LH-BJ7366L		TE2282R RHT M14x1.5	TE2281R			RE3085					
	Volkswagen	BORA													
		1999-on	Bora		RH-BJ7366R LH-BJ7366L		TE2282R RHT M14x1.5	TE2281R			RE3085				
		KOMBI - see VOLKSWAGON Commercial													
TYPE 3															
1962-64		Type III - Karmann Ghia, 1500, 1500S to chassis# 273513				TE132L	TE132R								
1964-68		Type III - Karmann Ghia, 1500, 1600 from chassis# 273514-on	BJ44	BJ45		TE132L	TE132L	TE132R	TE132R					TE1322	
1968-74	Type III - Karmann Ghia, 1600	BJ44	BJ45		TE495L	TE495L	TE495R	TE495R							
GOLF															
76-10/77	Golf LS hatchback		BJ2217 15mm stud		TE3629R	TE3629R									
11/77-80	Golf LS, GLS hatchback		BJ2022		TE3629R	TE3629R									

STEERING and SUSPENSION COMPONENTS



YEAR	MODEL	BALL JOINT UPPER	BALL JOINT LOWER / KING PIN SET	IDLER	TIE ROD END L/H OUTER	TIE ROD END R/H OUTER	TIE ROD END L/H INNER	TIE ROD END R/H INNER	RACK END	SIDE ROD	CENTRE ROD	DRAG LINK	PITMAN	NOTES/OTHER
------	-------	------------------	---------------------------------	-------	-----------------------	-----------------------	-----------------------	-----------------------	----------	----------	------------	-----------	--------	-------------

			17mm stud											
1998-on	Golf - Series IV		RH-BJ8303 LH-BJ9303		TE9303R	TE8303R			RE3072					
	PASSAT													
5/73-8/77	Passat		BJ706		TE3236R	TE3236R								
9/77-82	Passat GLS,LS,GLD to Chassis No. 32B080000		BJ2023		TE3236R	TE3236R								
82-84	Passat from Chassis No. 32B080001		BJ2023											
1985-on	Passat Synchro (with Steering Damper)		BJ8201											BJ8201 - 17mm not for Variant Engine 1.8-90kw
1988-93	Passat (except VR6)		BJ4012		TE9811R	TE9812R				RE6215 - manual steer to ch# 31NO80000 RE6216 - power steer to ch# 31NO80000 RE6224 - power steer from ch# 31NO80001 - on				
1994-on	Passat (except 16V - VR6) - to Chassis No. 3AR099264		BJ4012		TE9811R	TE9812R			RE6216					
1994-on	Passat (except 16V - VR6) - from Chassis No. 3AR099265		BJ4012		TE2281	TE2282			RE6164					
1997-on	Passat				TE4198R	TE4198R			RE4228					
	POLO													
1995-on	Polo - manual steer		RH-BJ8028 LH-BJ9028		TE2908R	TE2808R			RE6285					
1995-on	Polo - power steer		RH-BJ8028 LH-BJ9028		TE2908R	TE2808R			RE6286					

Volkswagen - Commercial

	CARAVELLE													
	Kombi													
1955-67	Kombi Van				TE132L	TE132R								Centre pin bush kit - OEM9817A

STEERING and SUSPENSION COMPONENTS



YEAR	MODEL	BALL JOINT UPPER	BALL JOINT LOWER / KING PIN SET	IDLER	TIE ROD END L/H OUTER	TIE ROD END R/H OUTER	TIE ROD END L/H INNER	TIE ROD END R/H INNER	RACK END	SIDE ROD	CENTRE ROD	DRAG LINK	PITMAN	NOTES/OTHER
------	-------	------------------	---------------------------------	-------	-----------------------	-----------------------	-----------------------	-----------------------	----------	----------	------------	-----------	--------	-------------

FORD

1967-80	Kombi Van - Torsion Bar Suspension	BJ147	BJ147		TE495L	TE495R								Centre pin bush kit - OEM9817A
1981-93	Kombi Van - Coil Spring Suspension	BJ7361 press in	BJ7187 3 bolt mount		TE495L	TE495R								Centre pin bush kit - OEM9817A
Transporter														
1955-67	Transporter Bus				TE132L	TE132R								Centre pin bush kit - OEM9817A
8/67-5/79	Transporter Type 2	BJ147	BJ147		TE495L	TE495L	TE495R	TE495R						Centre pin bush kit - OEM9817A
5/79-7/92	Transporter Type 2	BJ7361 18mm	BJ7187 20mm		TE4981R 14 x 1.5	TE4981R 14 x 1.5								
9/90-7/91	Transporter T4 Ch.70M.000001-70M.096448	BJ4187 20.5mm	BJ4361 18mm		TE4982L 16 x 1.5	TE4982R 16 x 1.5								
8/91-7/94	Transporter T4 Ch.70M.096449-70S.002791	BJ4187 20.5mm	BJ4361 18mm		TE4983L 16 x 1.5	TE4983R 16 x 1.5								
8/94-12/95	Transporter T4 Ch.70S.002792-70T.199999	BJ4187 20.5mm	BJ4361 18mm		TE4984L 16 x 1.5	TE4984R 16 x 1.5								
1/96-on	Transporter T4 Ch. 70T.200001- on	BJ4187 20.5mm	BJ4761 2 bolt		TE4985L 16 x 1.5	TE4985R 16 x 1.5								

VOLVO

VOLVO										RACK END FITMENT				
140/160 series														
1966-2/69	140,160 series - all models	BJ135	BJ136		TE498R	TE498R	TE498L	TE498L					Volvo series rack ends have found to vary greatly Please check measurements to determine fitment	BJ136 - body diameter 50mm
3/69-75	140,160 series - all models	BJ137	BJ136		TE498R	TE498R	TE498L	TE498L						BJ136 - body diameter 50mm
240/260 series														
1974-78	240,260 series - manual steer		BJ171		TE553R	TE553R			RE500					

STEERING and SUSPENSION COMPONENTS



YEAR	MODEL	BALL JOINT UPPER	BALL JOINT LOWER / KING PIN SET	IDLER	TIE ROD END L/H OUTER	TIE ROD END R/H OUTER	TIE ROD END L/H INNER	TIE ROD END R/H INNER	RACK END	SIDE ROD	CENTRE ROD	DRAG LINK	PITMAN	NOTES/OTHER
------	-------	------------------	---------------------------------	-------	-----------------------	-----------------------	-----------------------	-----------------------	----------	----------	------------	-----------	--------	-------------

1974-78	240,260 series - power steer		BJ171		TE553R	TE553R			RE666					
1979-90	240,260 series - all models		RH-BJ2025 LH-BJ2026 power steer		TE553R	TE553R			RE501 - power steer up to '89 RE502 - 1978-81 Cams Gear Rack RE504 - power steer '89-on					BJ2025/BJ2026 - offset bolt mounts - if straight bolt mounts required - use BJ171
	360 series													
1984-86	360 GLT - manual steer		BJ789		TE4981R 8/76 to 12/84 or TE2228 1/85 to 7/91	TE4981R 8/76 to 12/84 or TE2228 1/85 to 7/91			RE3277					
	740/760 series													
1983-88	740,760 series - all models		BJ1143		TE553R	TE553R			RE5531 Station Wagon > CH# 176799 Hatchback > CH# 294099					RE5531 - 18mm Rack End Thread
1989-on	740,760 series - all models		BJ1143		TE553R	TE553R			RE5539 Station Wagon CH# 176800 > Hatchback CH# 294100 >					RE5539 - 14mm Rack End Thread

WHITE TRUCKS

ROAD BOSS & COMMANDER														
1970-86	Road Boss 2, Road Commander 2, Western Star Conventional 4842 - also with Rockwell front axles FF920 & FF931 RB2-42T, RB62-T, 4842, 4864, 4942, 4964, RC2-42T, RC2-64T, RB2-64T, RBW-42T, RCW-42T, RBW-64T with F6W-1200 12000lb axle & single keyway king pin		300-235		310-222	310-223								King pin set with metal bushes 1.811" X 10.53"
1970-86	RB2-42T, RB62-T, 4842, 4864, 4942, 4964, RC2-42T, RC2-64T, RB2-64T, RBW-42T, RCW-42T, RBW-64T with FF933 12000lb axle		300-232		310-222	310-223								Twin keyway king pin set with metal bushes - 1.793" x 10.39"
1970-86	RB2-42T, RB62-T, 4842, 4864, 4942, 4964,		300-216		310-283	310-284								Twin keyway king pin set with

STEERING and SUSPENSION COMPONENTS



YEAR	MODEL	BALL JOINT UPPER	BALL JOINT LOWER / KING PIN SET	IDLER	TIE ROD END L/H OUTER	TIE ROD END R/H OUTER	TIE ROD END L/H INNER	TIE ROD END R/H INNER	RACK END	SIDE ROD	CENTRE ROD	DRAG LINK	PITMAN	NOTES/OTHER
------	-------	------------------	---------------------------------	-------	-----------------------	-----------------------	-----------------------	-----------------------	----------	----------	------------	-----------	--------	-------------

	RC2-42T,RC2-64T,RB2-64T,RBW-42T, RCW-42T, RBW-64T with other axle													metal bushes - 1.999" x 11.21"
	F120, F3-120, F3W-120, F5-120, F5W-120, F6W-120, 12,000 lb axles abd F5-140, F5W-140 with 14,000lb axle		300-142											King pin set - 1.812" x 10.75"

WOLSELEY														
1958-60	1500				TE126R	TE126R								
1961-70	Hornet Mk I,II,III	BJ29	BJ29		TE179R	TE179R								BJ29 - Ball joint repair kit
1962-67	24-80 Mk I,II		KX65							TE126R - Outer R/L TE126L - Inner R/L				
1965-72	1100 Mk I,II, 1300 Mk I,II	BJ37	BJ38		TE179R	TE179R								Front & Rear knuckle joint - BJ82 BJ37/38 - Ball joint repair kits
1967-72	18-85	BJ78	BJ78		TE125R	TE125R								Front & Rear knuckle joint - BJ79

STEERING and SUSPENSION COMPONENTS